

NOTICE DE MONTAGE
INSTALLATION INSTRUCTIONS
MANUAL DE INSTALACIÓ
MANUAL DE INSTALAÇÃO
ISTRUZIONI DI MONTAGGIO
INSTALLATIE VOORSCHRIFTEN
INSTALLATIONSANLEITUNG

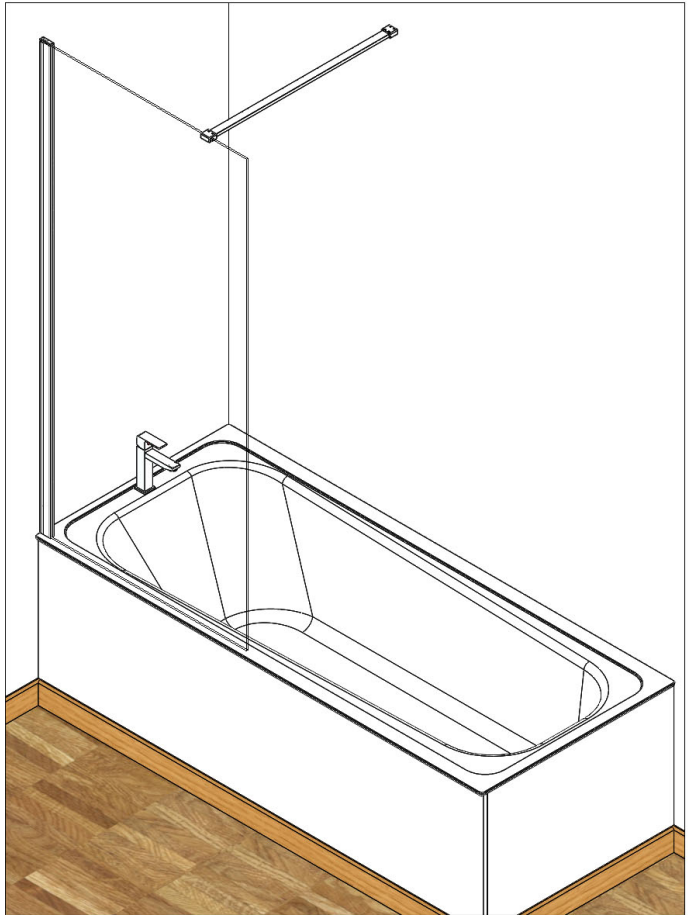

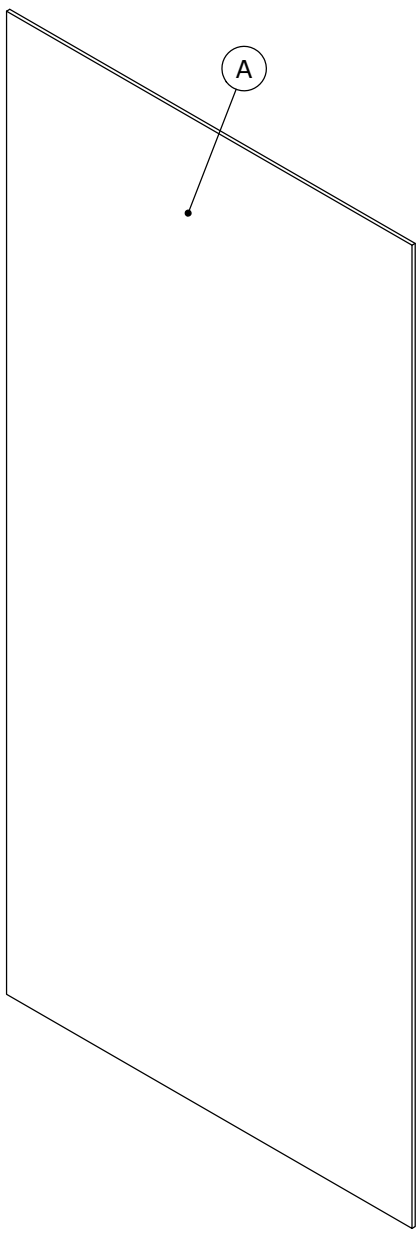

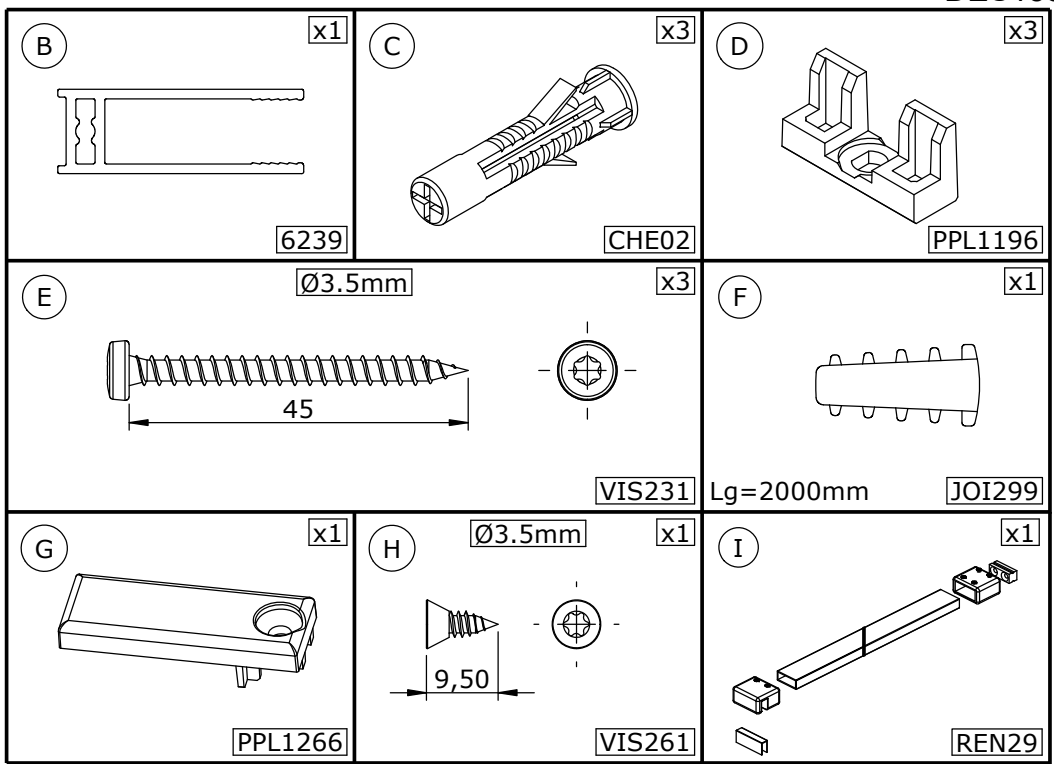

- Les quantités données sont les quantités utiles au montage. les sachets fournis contiennent des pièces supplémentaires.
 - The quantities given are what are required for the installation. There may be some surplus in the package provide.
- Las cantidades indicadas son las cantidades necesarias para el montaje. Las bolsitas incluidas contienen piezas suplementarias.
 - Le quantità fornite sono le quantità necessarie al montaggio. I sacchetti forniti contengono pezzi supplementari.
 - De aangegeven aantallen zijn vereist voor de montage. De verpakking bevat extra onderdelen.
 - Die Mengenangaben beziehen sich auf die für die Montage nötigen Teile. Eventuell weitere beige packte Teile ignorieren.

Matériel nécessaire - Tools required
 Equipamiento necesario - Equipamento necessário
 Materiale necessario - Benodigd gereedschap - Benötigte Werkzeuge

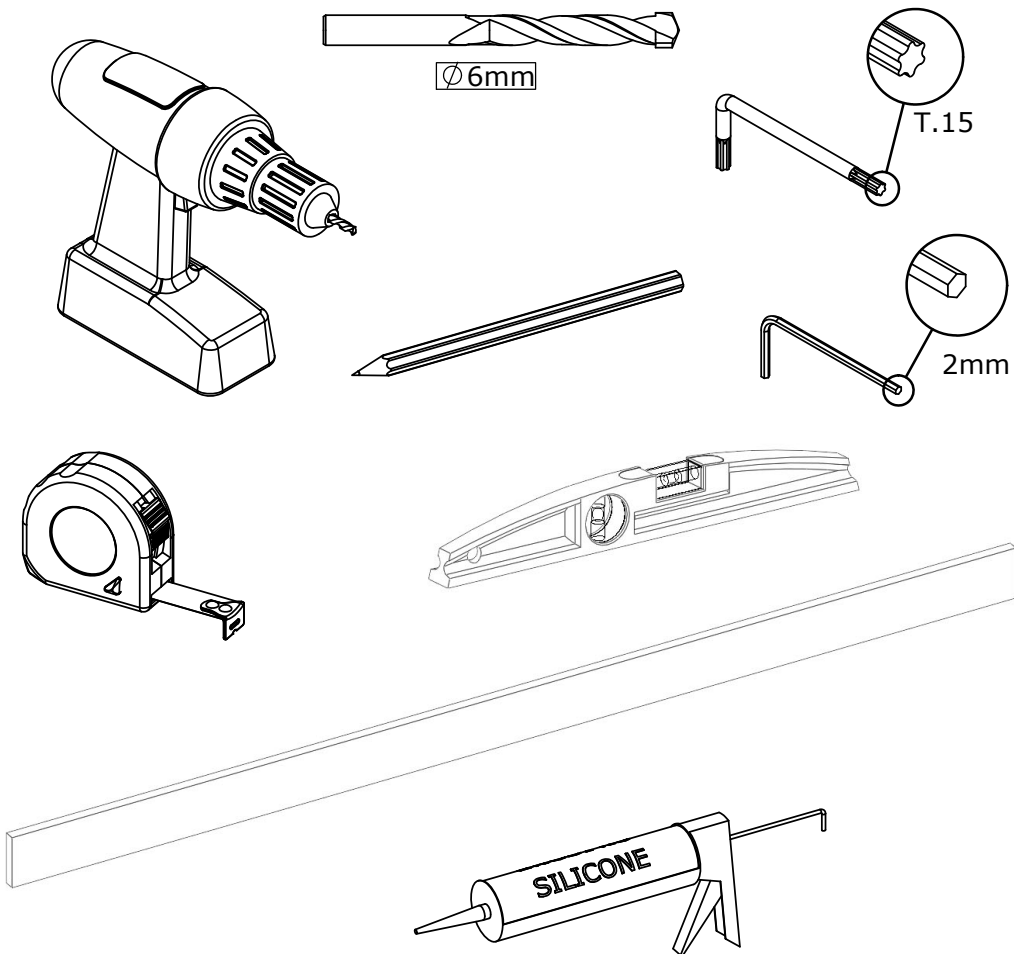

Utiliser un silicone adapté au matériau de chaque support (faïence, acrylique, etc.)
 Use a silicone sealant that is intended for the surrounding materials (ceramic, acrylic, etc.)
 Usar una silicona adecuada para cada tipo de material (loza, acrílico, etc.)
 Usar una silicona adecuada para cada tipo de material (loza, acrílico, etc.)
 Utilizzare un silicone adatto a qualsiasi materiale (ceramica, acrilico, ecc.)
 Gebu ik siliconenkit die geschikt is voor iedere ondergrond (tegelwerk, acryl, etc.)
 Für das jeweilige Trägermaterial (Stein, Acryl usw.) geeignetes Silikon verwenden.



REVERSIBILITE - REVERSIBILITY - REVERSIBILIDAD - REVERSIBILIDADE
 REVERSIBILITA - OMKEERBAARHEID - WAHLWEISE MONTAGE

Montage à gauche
 Left hand

Montaje a la izquierda
 Montagem à esquerda
 Montaggio sinistra
 Montage links
 Montage links

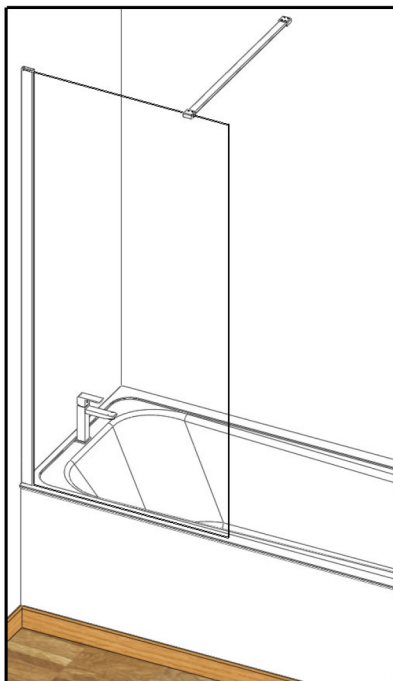

Montage à droite
 Right hand

Montaje a la derecha
 Montagem à direita
 Montaggio a destra
 Montage rechts
 Montage rechts

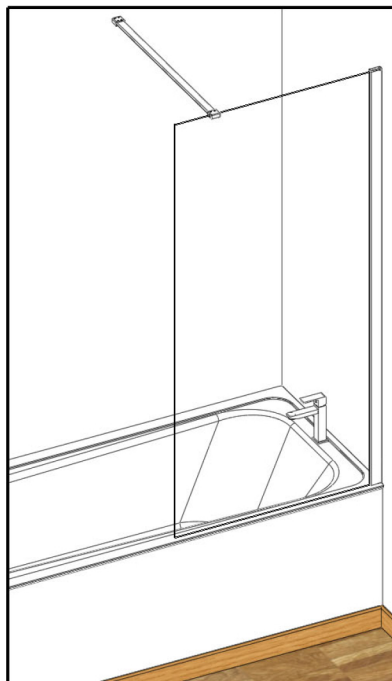

- Vous avez la possibilité de réaliser un montage à droite ou un montage à gauche. Notre notice d'installation décrit un montage à gauche. Si vous voulez réaliser un montage à droite, il vous suffit d'inverser le montage.
- This cubicle can be installed either left or right hand. These installation instructions show a left hand installation.
- Puede realizar un montaje a la derecha o un montaje a la izquierda. Nuestro folleto de instalación describe un montaje a la izquierda. Si desea montar su cabina a la derecha sólo tendrá que realizar el montaje al contrario.
- Pode realizar uma instalação à direita ou uma instalação à esquerda. O nosso manual de instalação descreve uma instalação à esquerda. Se pretende realizar uma instalação à direita, basta inverter a instalação.
- Avete la possibilità di effettuare il montaggio a destra o a sinistra. Il nostro manuale descrive il montaggio a sinistra. Se volete realizzare il montaggio a destra è sufficiente invertire varie fasi di montaggio.
- U kunt de douchecabine rechts of links monteren. Onze handleiding beschrijft de links montage van de cabine. Keer de montage om als u de cabine rechts wilt monteren.
- Sie haben die Möglichkeit, eine Montage auf der linken Seite oder eine Montage auf der rechten Seite durchzuführen. Unsere Montageanleitung beschreibt eine Montage auf der linken Seite. Wenn Sie die Montage lieber auf der rechten Seite durchführen wollen, müssen Sie nur den Montageprozess umkehren.

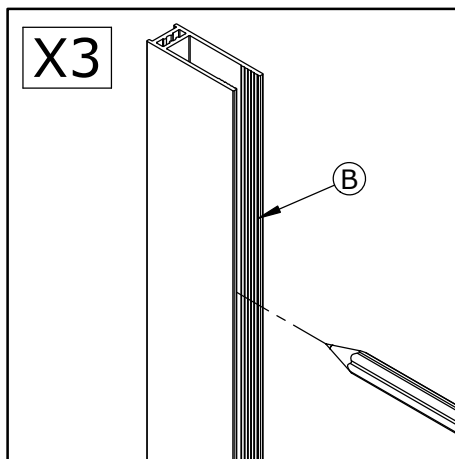
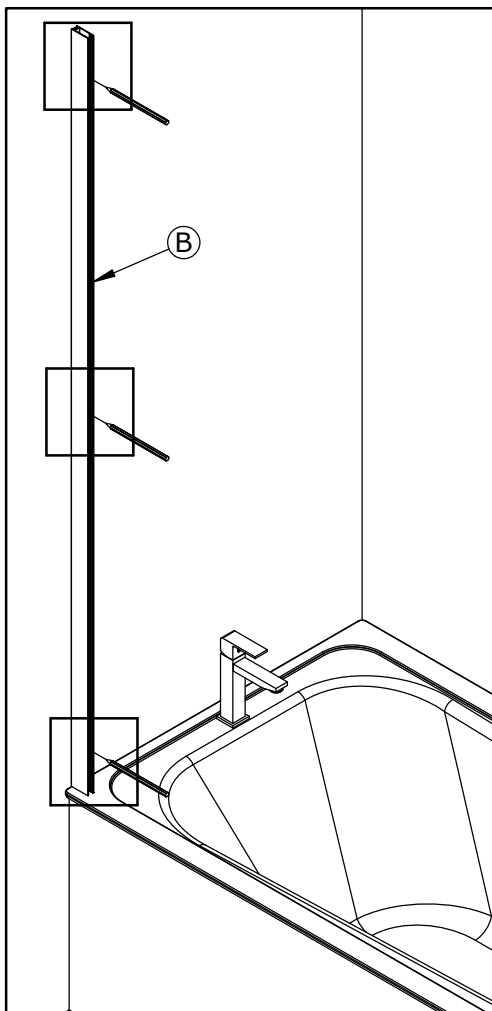
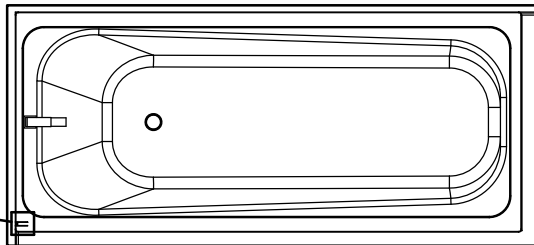
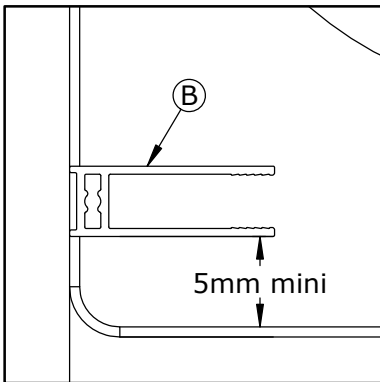

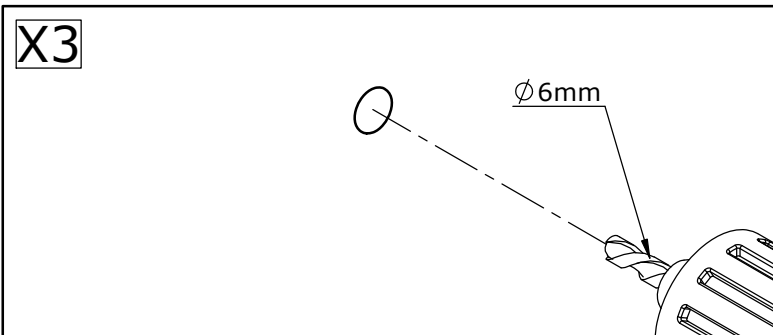
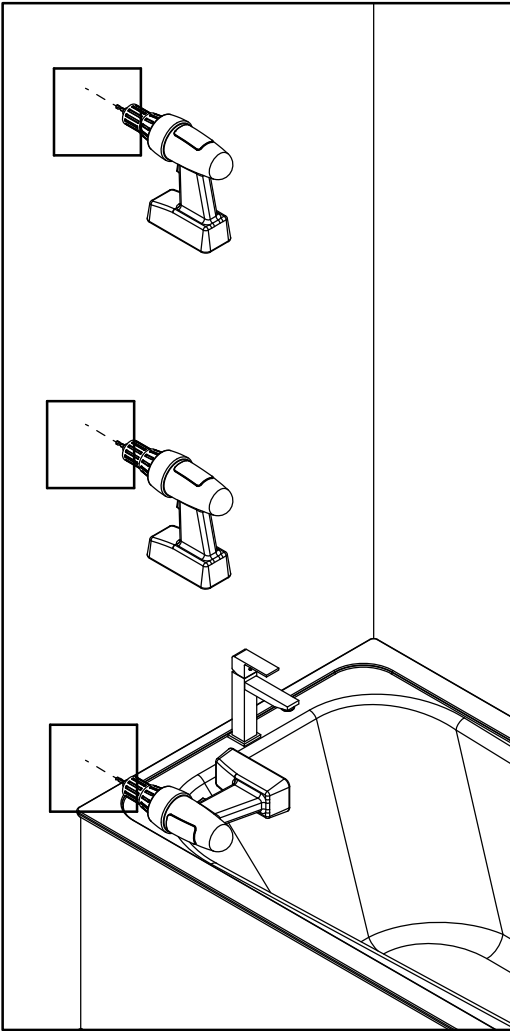

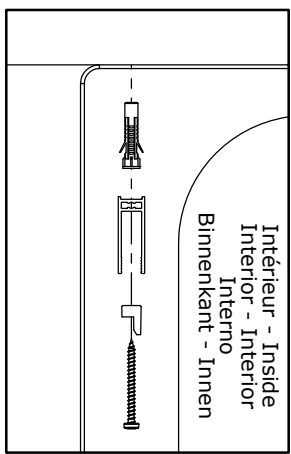
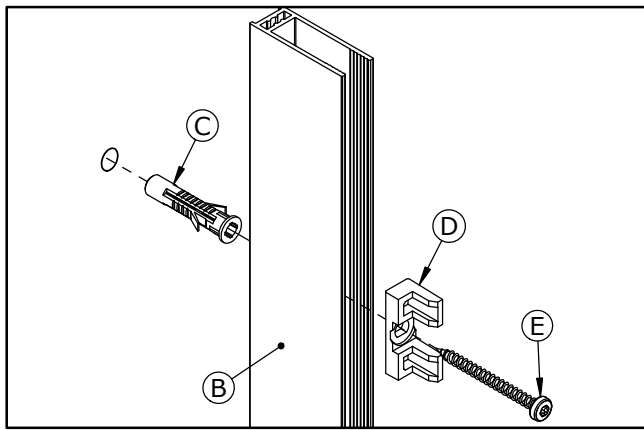
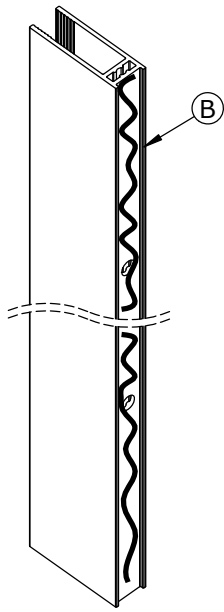
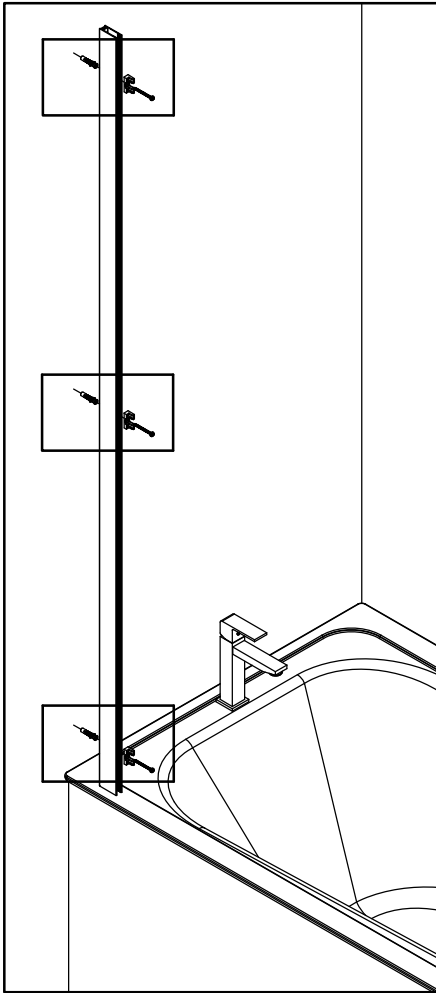

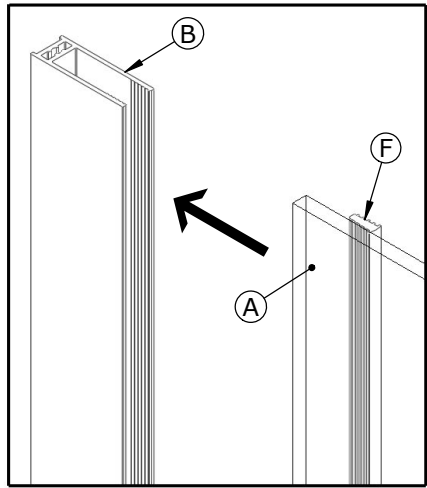
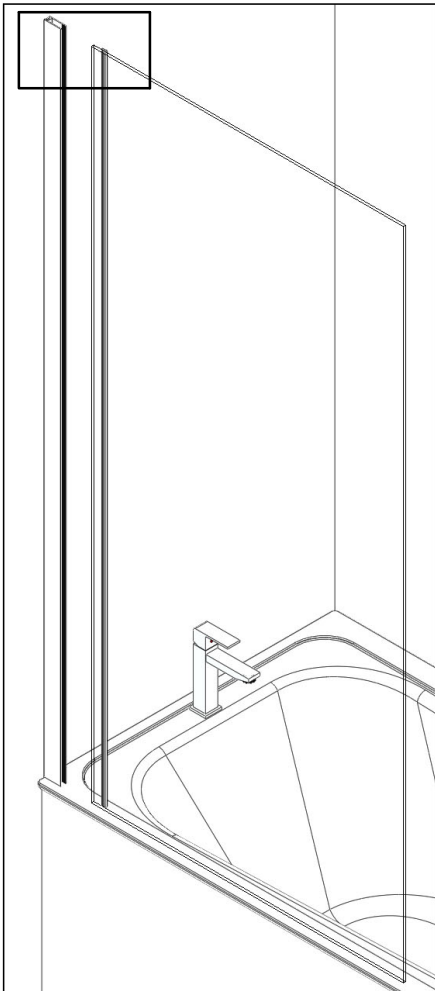

Intérieur - Inside - Interior - Interior
Interno - Binnenkant - Innen

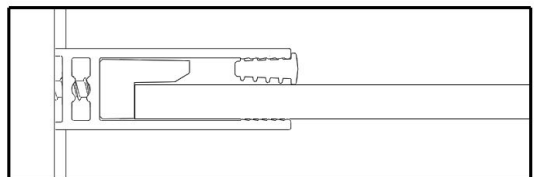
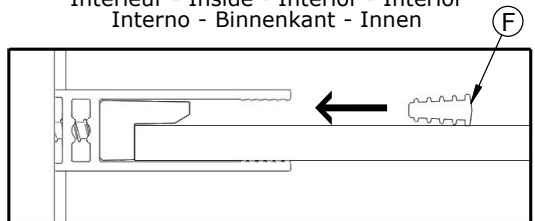

Montage barre de renfort, voir notice concernée
Mounting of reinforcement bar, see relevant instructions
Montaje de la barra de refuerzo, consulte el manual correspondiente
Montagem da barra de reforço, consulte o manual correspondente
Montaggio barra di rinforzo, vedere manuale
Zie de betreffende montagehandleiding voor de montage van muursteen
Montage der Verstärkungsstange, siehe entsprechende Anleitung

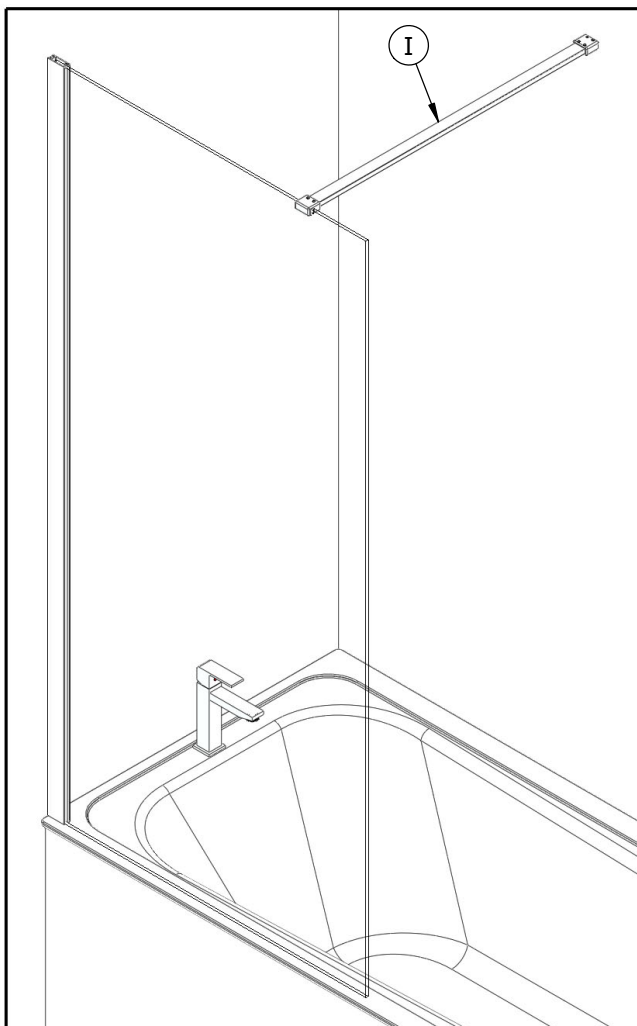
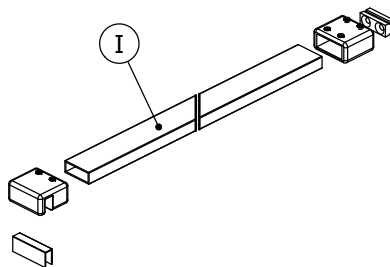

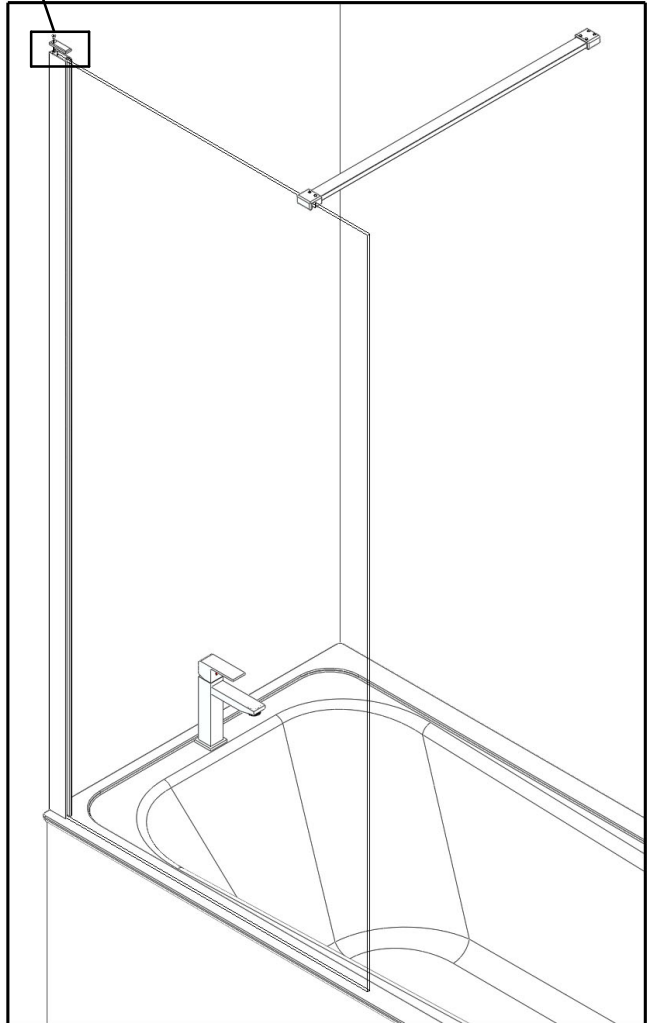
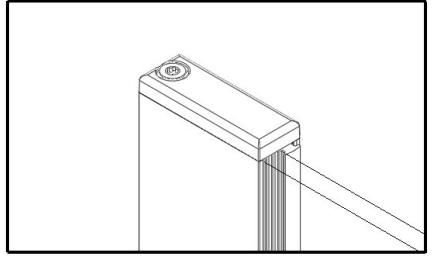
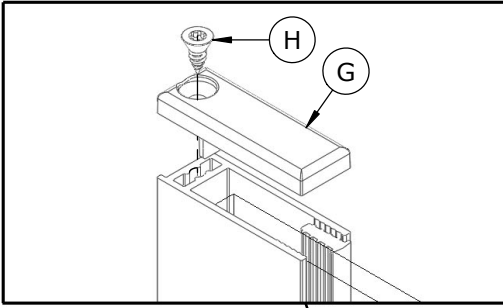



24h

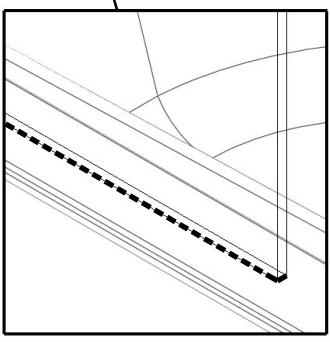
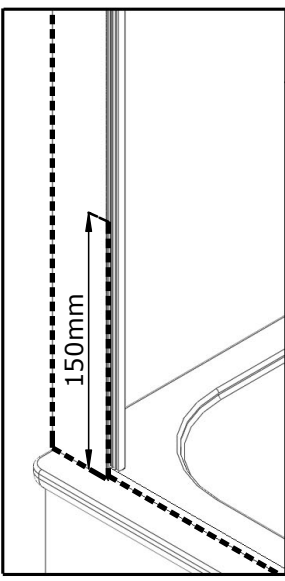
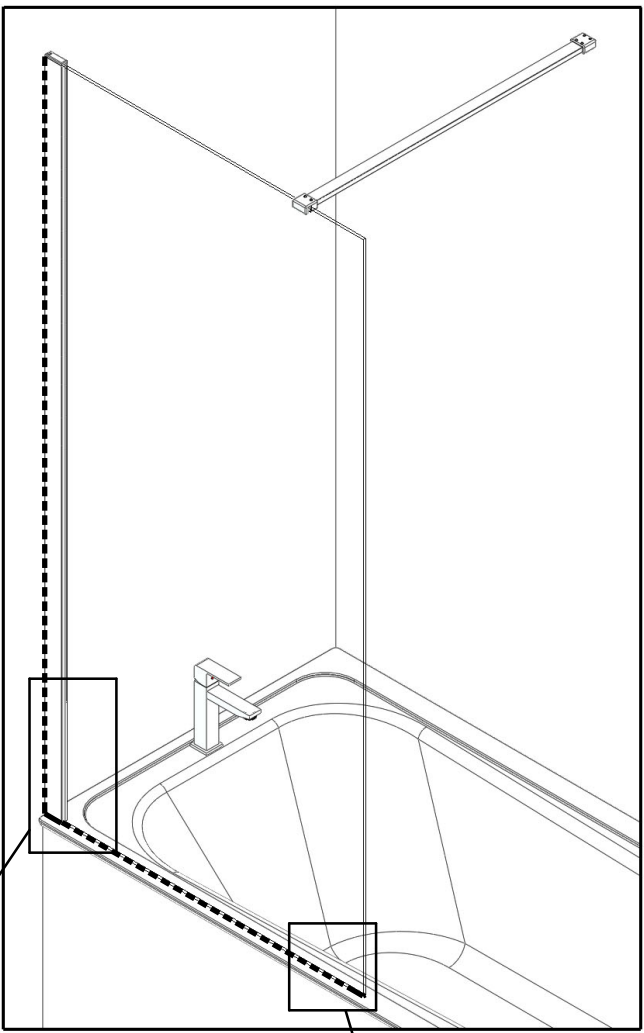

**NOTICE D'ENTRETIEN
MAINTENANCE INSTRUCTIONS
ISTRUZIONI DI MANUTENZIONE
INSTRUCCIONES DE MANTENIMIENTO
ONDERHOUDSINSTRUCTIE
WARTUNGSANLEITUNG**



SCAN ME





AQUAPRODUCTION, Site industriel,
F - 44680 Chaumes-en-Retz

22

EN 14428

Paroi de douche, fabriquée en verre de silicate
sodo-calcique de sécurité trempé thermiquement

Aptitude au nettoyage : réussite

Résistance à l'impact/propriétés de fragmentation : réussite

Durabilité : réussite



SERVICE APRÈS-VENTE AFTER-SALES SERVICE

FRANCE

+33 (0)2 40 21 29 45

UK

+44 (0)20 8842 0033

IRELAND

+353 04697 33102

DEUTSCHLAND

+49 (0) 6074 / 30928 0

ITALIA

+39 (0382) 6181

ÖSTEREICH

+43 1 710 60 70

SUISSE/SCHWEIZ

+41 (0)32 631 04 74

ESPAÑA

+34 93 544 60 76

NEDERLAND

+31 475 487 100

BELGIQUE/BELGIË

+31 475 487 100

РОССИЯ

+7 495 258-29-51

PORTUGAL

+351 219 112 785