

Notre service technique est
à votre écoute aux numéros
qui sont au dos de cette
notice d'installation

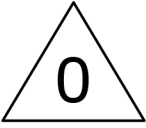

● Position de la cabine ● Position of the shower cubicle
 ● Posición de la cabina de ducha ● Posizione della cabina doccia
 ● Positie van de douchecabine ● Position der Duschkabine

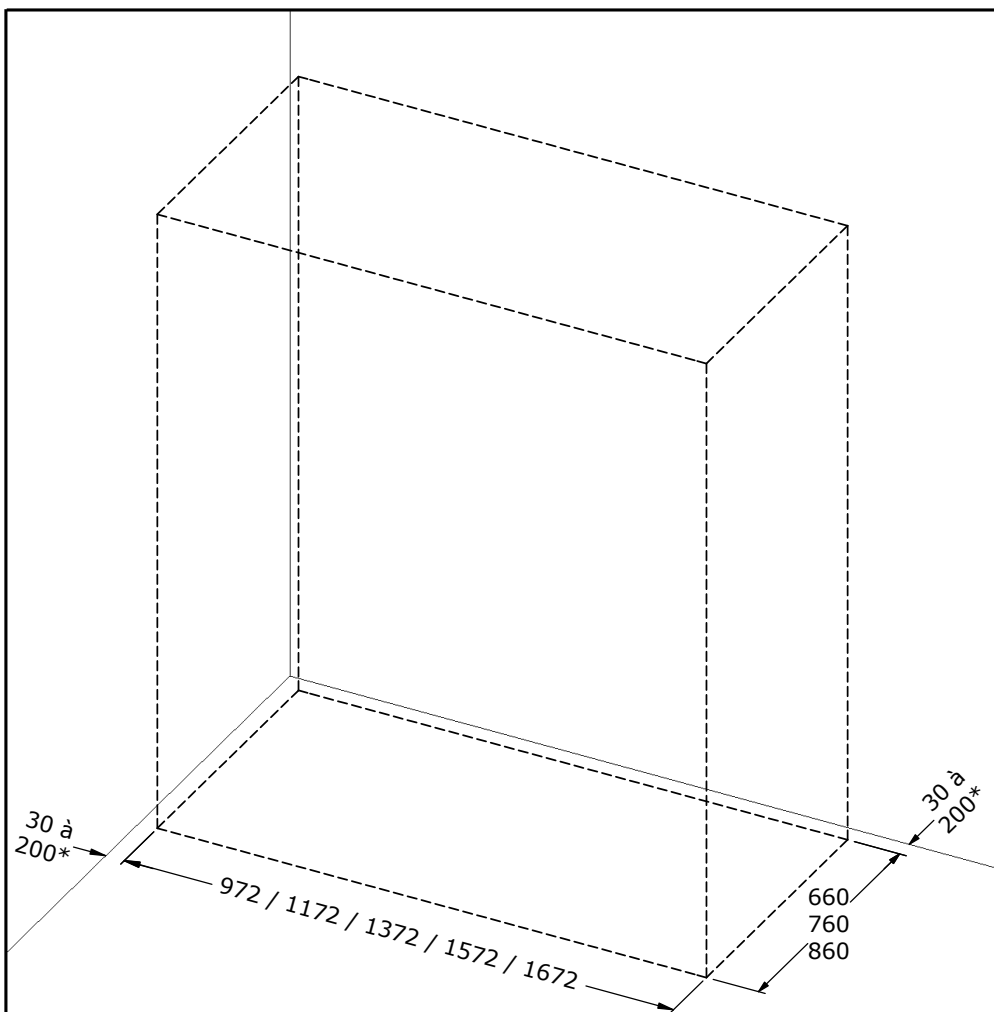

● Cotes en mm ● Dimensions in mm ● Cotas en mm
 ● Quote in mm ● Afmetingen in mm ● Maße sind in mm angegeben

* ● Côté gauche et droit cumulés ne peuvent excéder 385 mm.

● Left and right sides summed must not exceed 385 mm.

● Las cuotas agregadas izquierda y derecha no pueden superar 385 mm.

● Sinistra e destra combinati non possono superare 385 mm.

● De linker- en rechterzijde mogen samen niet groter zijn dan 385 mm.

● Links und rechts dürfen es zusammen nicht mehr als 385 mm sein.

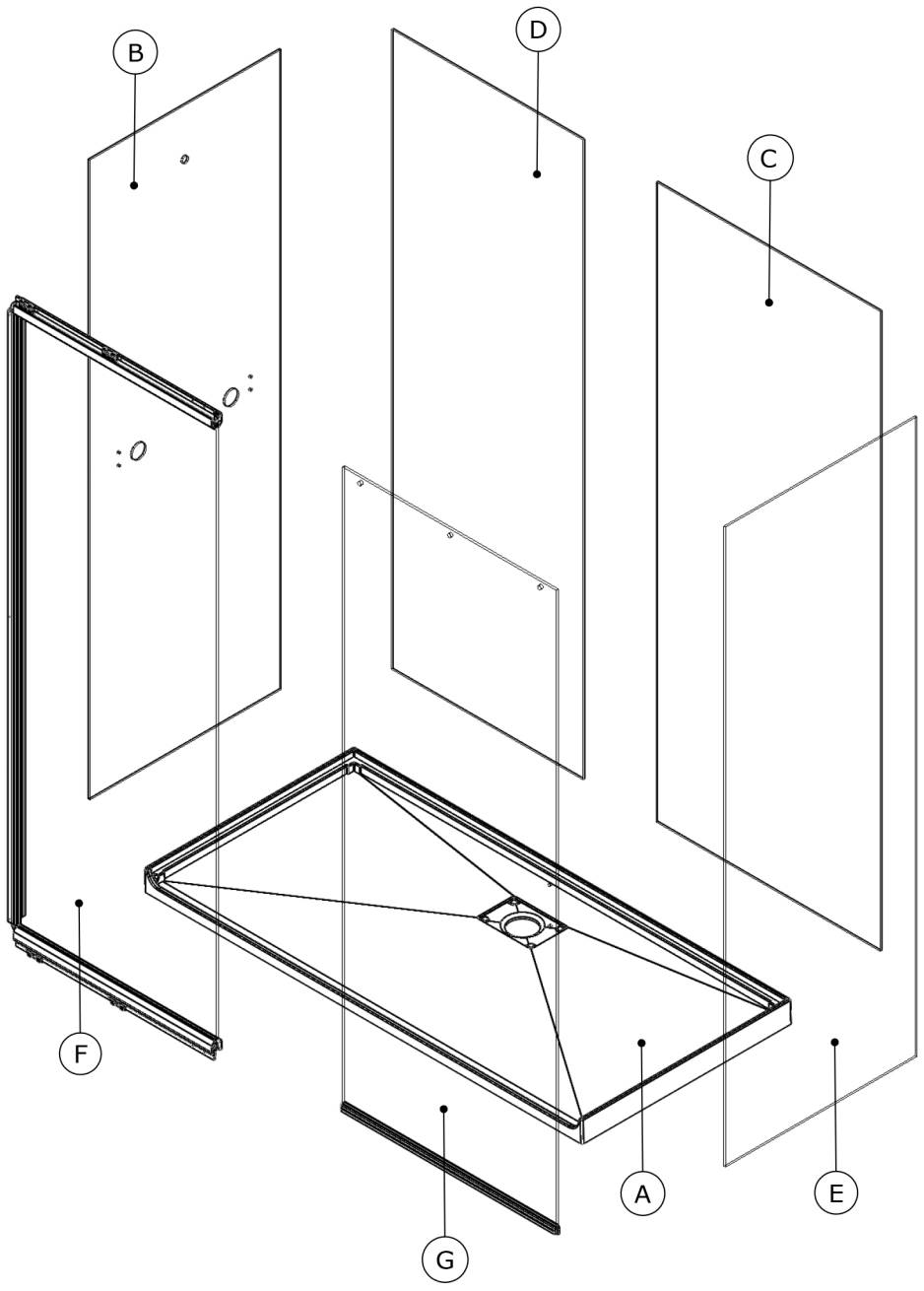

- CODE COLIS (Voir repères en page 4)
- PACKAGE CODES (See marks on page 4)
- REF. BULTOS (Ver pg. 4 para listado de bultos)
- CODE SET (zie blz. 4)
- Codering verpakking (zie omschrijving op pagina 4)
- PAKETCODES (siehe Kennzeichnungen auf Seite 4)

REP	VERSION	100 x 70	100 x 80	100 x 90	120 x 70	120 x 80	120 x 90	140 x 70	140 x 80	140 x 90	160 x 70	160 x 80	160 x 90	170 x 70	170 x 80	170 x 90	
A		REC561	REC562	REC563	REC564	REC565	REC566	REC567	REC568	REC569	REC570	REC571	REC572	REC573	REC574	REC575	
B	Beige orient	C13889	C13891	C13893	C13889	C13891	C13893	C13889	C13891	C13893	C13889	C13891	C13893	C13889	C13891	C13893	
	Gris bois	C13890	C13892	C13894	C13890	C13892	C13894	C13890	C13892	C13894	C13890	C13892	C13894	C13890	C13892	C13894	
C	Beige orient	C13875			C13878			C13872			C13872			C13872			
	Gris orient	C13874			C13877			C13871			C13871			C13871			
	Gris bois	C13876			C13879			C13873			C13873			C13873			
D	Beige orient							C13863			C13866			C13869			
	Gris orient							C13862			C13865			C13868			
	Gris bois							C13864			C13867			C13870			
E	SER	C11366E	C11367E	C11368E	C11366E	C11367E	C11368E	C11366E	C11367E	C11368E	C11366E	C11367E	C11368E	C11366E	C11367E	C11368E	
	TN	C11360E	C11361E	C11362E	C11360E	C11361E	C11362E	C11360E	C11361E	C11362E	C11360E	C11361E	C11362E	C11360E	C11361E	C11362E	
F	SER	CLT	C11374E			C11375E			C11376E			C11377E			C11378E		
		PVT/ SOLO	C11381E			C11382E			C11498E			C11496E			C11420E		
	TN	CLT	C11369E			C11370E			C11371E			C11372E			C11373E		
		PVT/ SOLO	C11379E			C11380E			C11497E			C11421E			C11419E		
G	SER	CLT	C11394E			C11395E			C11396E			C11397E			C11398E		
		PVT	C11401E			C11401E											
	TN	CLT	C11389E			C11390E			C119391E			C11392E			C11393E		
		PVT	C11399E			C11399E											

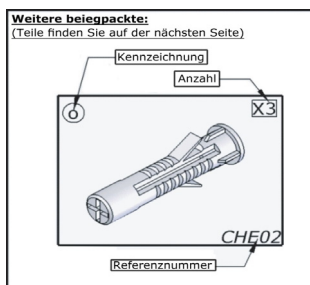
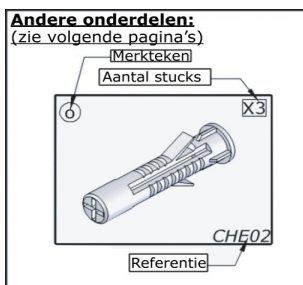
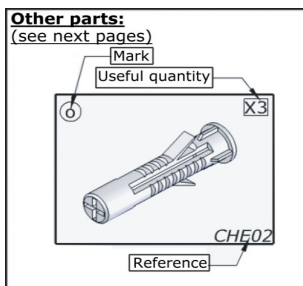
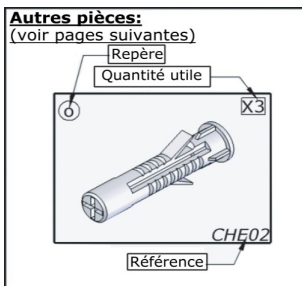



<p>SK</p> <ul style="list-style-type: none"> ● Montage gauche ● Left hand ● Montaje a la izquierda ● Montaggio a sinistra ● Montage links ● Montage links <p>SUP172</p>	<p>SL</p> <ul style="list-style-type: none"> ● Montage droite ● Right hand ● Montaje a la derecha ● Montaggio a destra ● Montage rechts ● Montage rechts <p>SUP173</p>	<p>PS</p> <p>PPL1116</p>
<p>SC</p> <ul style="list-style-type: none"> ● Montage gauche ● Left hand ● Montaje a la izquierda ● Montaggio a sinistra ● Montage links ● Montage links <p>SUP164</p>	<p>SD</p> <ul style="list-style-type: none"> ● Montage droite ● Right hand ● Montaje a la derecha ● Montaggio a destra ● Montage rechts ● Montage rechts <p>SUP165</p>	<p>PT</p> <p>140/160/170 x1 100/120 x0</p> <p>PPL1117</p>
<p>PG</p> <ul style="list-style-type: none"> ● Montage gauche ● Left hand ● Montaje a la izquierda ● Montaggio a sinistra ● Montage links ● Montage links <p>PPL1102</p>	<p>PH</p> <ul style="list-style-type: none"> ● Montage droite ● Right hand ● Montaje a la derecha ● Montaggio a destra ● Montage rechts ● Montage rechts <p>PPL1103</p>	<p>PU</p> <p>PPL1118</p>
<p>PAB</p> <ul style="list-style-type: none"> ● Montage gauche ● Left hand ● Montaje a la izquierda ● Montaggio a sinistra ● Montage links ● Montage links <p>PPL1134</p>	<p>PAC</p> <ul style="list-style-type: none"> ● Montage droite ● Right hand ● Montaje a la derecha ● Montaggio a destra ● Montage rechts ● Montage rechts <p>PPL1135</p>	<p>PAT</p> <p>PPL1141</p>

1

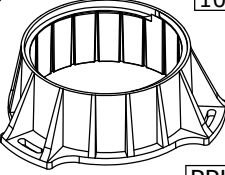
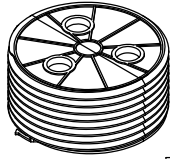
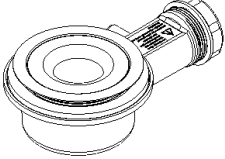
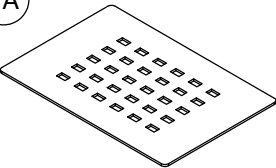
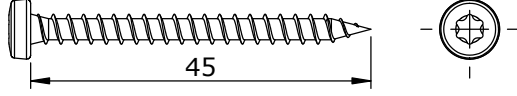
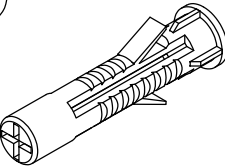
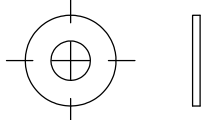
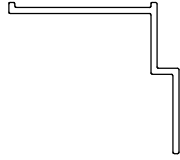
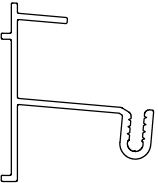
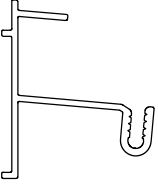
<p>PA 120/140/160/170 x11 100 x9</p>  <p>PPL802</p>	<p>PB 120/140/160/170 x11 100 x9</p>  <p>PPL804</p>	<p>QA x1</p>  <p>BOND28</p>													
<p>TA x1</p>  <p>TOL11</p>	<p>VN Ø4 x11</p>  <p>1=1 VIS231</p>														
<p>VA x11</p>  <p>CHE02</p>	<p>VV x11</p>  <p>RON34</p>	<p>AW x2</p>  <p>Lg=1940mm 6210-01</p>													
<p>AS x1</p>  <table border="1" data-bbox="694 1149 1075 1292"> <thead> <tr> <th colspan="2">6209</th> </tr> <tr> <th>● Largeur ● Width ● Ancho</th> <th>● Lunghezza ● Breedte ● Breite</th> </tr> </thead> <tbody> <tr> <td>70</td> <td>Lg=635mm</td> </tr> <tr> <td>80</td> <td>Lg=735mm</td> </tr> <tr> <td>90</td> <td>Lg=835mm</td> </tr> </tbody> </table>		6209		● Largeur ● Width ● Ancho	● Lunghezza ● Breedte ● Breite	70	Lg=635mm	80	Lg=735mm	90	Lg=835mm				
6209															
● Largeur ● Width ● Ancho	● Lunghezza ● Breedte ● Breite														
70	Lg=635mm														
80	Lg=735mm														
90	Lg=835mm														
<p>AT x1</p>  <table border="1" data-bbox="655 1340 1075 1548"> <thead> <tr> <th colspan="2">6209</th> </tr> <tr> <th>● Longueur ● Length ● Largo</th> <th>● Lunghezza ● Lengte ● Länge</th> </tr> </thead> <tbody> <tr> <td>100</td> <td>Lg=950mm</td> </tr> <tr> <td>120</td> <td>Lg=1150mm</td> </tr> <tr> <td>140</td> <td>Lg=1350mm</td> </tr> <tr> <td>160</td> <td>Lg=1550mm</td> </tr> <tr> <td>170</td> <td>Lg=1650mm</td> </tr> </tbody> </table>		6209		● Longueur ● Length ● Largo	● Lunghezza ● Lengte ● Länge	100	Lg=950mm	120	Lg=1150mm	140	Lg=1350mm	160	Lg=1550mm	170	Lg=1650mm
6209															
● Longueur ● Length ● Largo	● Lunghezza ● Lengte ● Länge														
100	Lg=950mm														
120	Lg=1150mm														
140	Lg=1350mm														
160	Lg=1550mm														
170	Lg=1650mm														

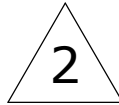

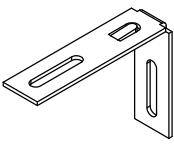
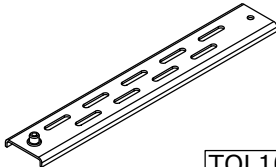
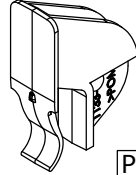
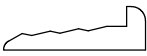
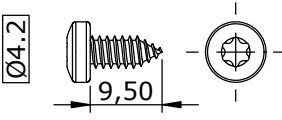
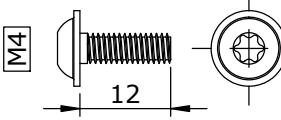
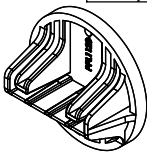
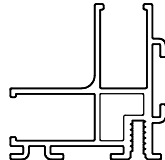
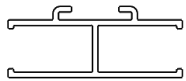
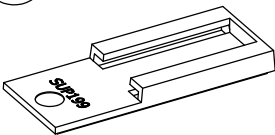

<p>(TE) 140/160/170 x6 100/120 x4</p>  <p style="text-align: right;">TOL102</p>	<p>(TF) 140/160/170 x6 100/120 x4</p>  <p style="text-align: right;">TOL103</p>	<p>(PAA) 140/160/170 x7 100/120 x5</p>  <p style="text-align: right;">PPL1133</p>
<p>(JG) 140/160/170 x6 100/120 x4</p>  <p>Lg=1971mm P101</p>	<p>(VQ) 140/160/170 x5 100/120 x4</p>  <p style="text-align: right;">1=1 VIS238</p>	<p>(VR) 140/160/170 x6 100/120 x4</p>  <p style="text-align: right;">1=1 VIS239</p>
<p>(PAL) 140/160/170 x1 100/120 x0</p>  <p style="text-align: right;">PPL1128</p>	<p>(AA) x2</p>  <p>Lg=1972mm 6189-01</p>	<p>(AB) 140/160/170 x1 100/120 x0</p>  <p>Lg=1972mm 6190-01</p>
<p>(VAB) 140/160/170 x3 100/120 x2</p>  <p style="text-align: right;">SET167</p>		

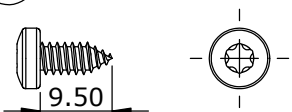
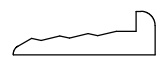
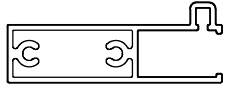
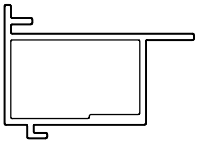
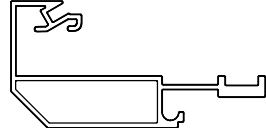
3

<p>(VQ) Ø4.2 x3</p>  <p>1=1 VIS238</p>	<p>(JG) x1</p>  <p>Lg=1971mm P101</p>	<p>(AC) x1</p>  <p>Lg=1944mm 6192-01</p>												
<p>(AP) x1</p>  <p>Lg=1952mm 6205-01</p>	<p>(AI) x1</p>  <table border="1" data-bbox="694 646 1075 790"> <thead> <tr> <th colspan="2">6198</th> </tr> <tr> <th>• Largeur • Width • Ancho</th> <th></th> </tr> <tr> <th>• Larghezza • Breedte • Breite</th> <th></th> </tr> </thead> <tbody> <tr> <td>70</td> <td>Lg=567mm</td> </tr> <tr> <td>80</td> <td>Lg=667mm</td> </tr> <tr> <td>90</td> <td>Lg=767mm</td> </tr> </tbody> </table>		6198		• Largeur • Width • Ancho		• Larghezza • Breedte • Breite		70	Lg=567mm	80	Lg=667mm	90	Lg=767mm
6198														
• Largeur • Width • Ancho														
• Larghezza • Breedte • Breite														
70	Lg=567mm													
80	Lg=667mm													
90	Lg=767mm													

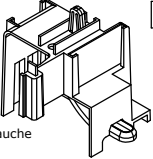
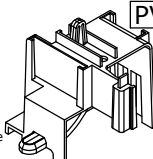
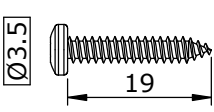
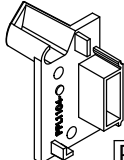
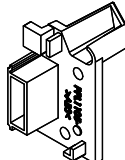
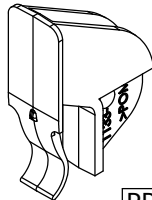
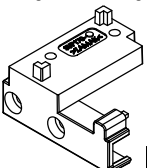
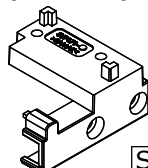

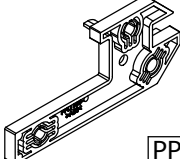
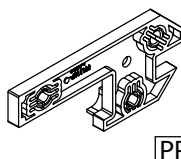
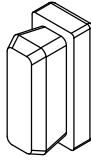
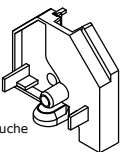
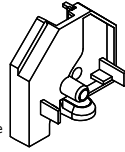
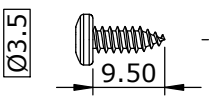
<p>SA SOLO/CLT x1 PVT x0</p>  <ul style="list-style-type: none"> ● Montage gauche ● Left hand ● Montaje a la izquierda ● Montaggio a sinistra ● Montage links ● Montage links <p>SET107</p>	<p>SB SOLO/CLT x1 PVT x0</p>  <ul style="list-style-type: none"> ● Montage droite ● Right hand ● Montaje a la derecha ● Montaggio a destra ● Montage rechts ● Montage rechts <p>SET108</p>	<p>VM CLT/PVT/RID x8 SOLO x9</p>  <p>1=1 VIS215</p>
<p>PI ● Montage gauche ● Left hand ● Montaje a la izquierda ● Montaggio a sinistra ● Montage links ● Montage links</p>  <p>PPL1104</p>	<p>PJ ● Montage droite ● Right hand ● Montaje a la derecha ● Montaggio a destra ● Montage rechts ● Montage rechts</p>  <p>PPL1105</p>	<p>PAA</p>  <p>PPL1133</p>
<p>SI ● Montage gauche ● Left hand ● Montaje a la izquierda ● Montaggio a sinistra ● Montage links ● Montage links</p>  <p>SUP170</p>	<p>SJ ● Montage droite ● Right hand ● Montaje a la derecha ● Montaggio a destra ● Montage rechts ● Montage rechts</p>  <p>SUP171</p>	<p>JG</p>  <p>Lg=1971mm P101</p>
<p>PK ● Montage gauche ● Left hand ● Montaje a la izquierda ● Montaggio a sinistra ● Montage links ● Montage links</p>  <p>PPL1106</p>	<p>PL ● Montage droite ● Right hand ● Montaje a la derecha ● Montaggio a destra ● Montage rechts ● Montage rechts</p>  <p>PPL1107</p>	<p>QC</p>  <p>BUT22</p>
<p>PV SOLO/PVT x1 CLT x0</p>  <ul style="list-style-type: none"> ● Montage gauche ● Left hand ● Montaje a la izquierda ● Montaggio a sinistra ● Montage links ● Montage links <p>PPL1126</p>	<p>PW SOLO/PVT x1 CLT x0</p>  <ul style="list-style-type: none"> ● Montage droite ● Right hand ● Montaje a la derecha ● Montaggio a destra ● Montage rechts ● Montage rechts <p>PPL1127</p>	<p>VP SOLO/CLT/RID x3 PVT x2</p>  <p>1=1 VIS237</p>

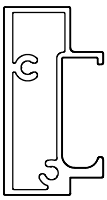
AG  x1

6196	
● Longueur ● Length ● Largo ● Lunghezza ● Lengte ● Länge	Lg=880mm
100	Lg=880mm
120	Lg=1080mm
140	Lg=1280mm
160	Lg=1480mm
170	Lg=1580mm

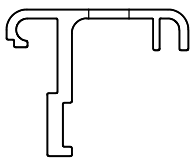
AD  x1

6194		
● Longueur ● Length ● Largo ● Lunghezza ● Lengte ● Länge	CLT	SOLO / 2P
100	Lg=456mm	Lg=673mm
120	Lg=556mm	Lg=673mm
140	Lg=656mm	Lg=506mm
160	Lg=756mm	Lg=606mm
170	Lg=806mm	Lg=706mm

AJ  x1

6199		
● Longueur ● Length ● Largo ● Lunghezza ● Lengte ● Länge	CLT	SOLO / 2P
100	Lg=401mm	Lg=183mm
120	Lg=501mm	Lg=383mm
140	Lg=601mm	Lg=751mm
160	Lg=701mm	Lg=851mm
170	Lg=751mm	Lg=851mm

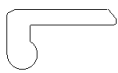
AQ  x2

Lg=300mm 6206-01

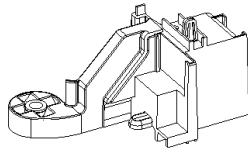
SM 

- Montage gauche ● Left hand
- Montaje a la izquierda
- Montaggio a sinistra
- Montage links ● Montage links

PVT: x1

CLT: x0

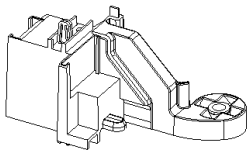
SET115 

- Montage droite ● Right hand
- Montaje a la derecha
- Montaggio a destra
- Montage rechts ● Montage rechts

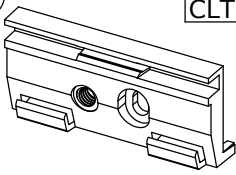
PF  x4

PVT x4

CLT x0

PPL1099

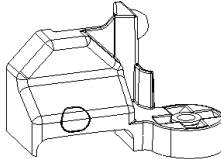
SN 

- Montage gauche ● Left hand
- Montaje a la izquierda
- Montaggio a sinistra
- Montage links ● Montage links

PVT: x1

CLT: x0

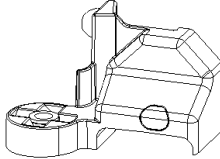
SET114 

- Montage droite ● Right hand
- Montaje a la derecha
- Montaggio a destra
- Montage rechts ● Montage rechts

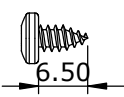
VO  x4

Ø3.5 PVT x4

CLT x0

6.50

1=1 VIS234

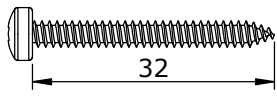
VAA  x1

Ø3.5 PVT x1

CLT x0



32

1=1 VIS214

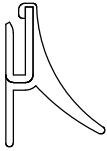
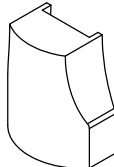
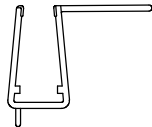
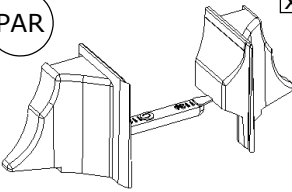
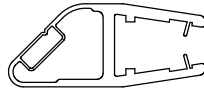
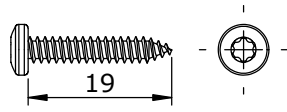
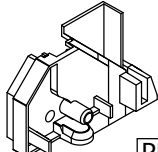
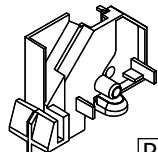
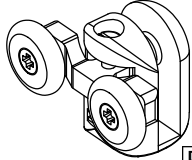
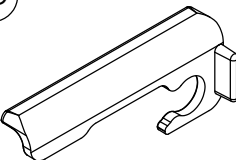
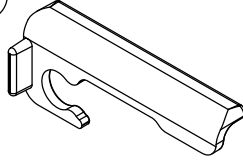
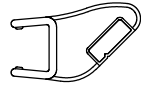
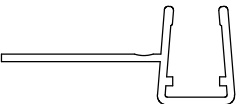
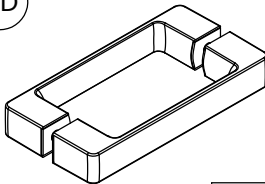

5 CLT

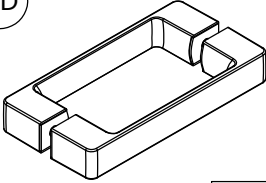
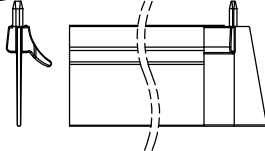
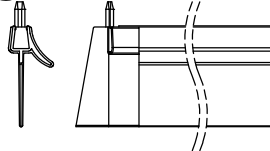
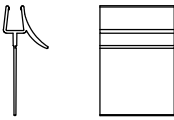
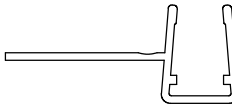
<p>JE x1</p>  <p>Lg=820mm JOI239</p>	<p>PC x1</p>  <p>PPL823</p>	<p>JC x1</p>  <p>Lg=1882mm J723</p>
<p>PAR x1</p>  <p>PPL1136/1137</p>	<p>JB x1</p>  <p>Lg=1959mm AI150</p>	<p>VM Ø3.5 x1</p>  <p>1=1 VIS215</p>
<p>PO x1</p> <ul style="list-style-type: none"> ● Montage gauche ● Left hand ● Montaje a la izquierda ● Montaggio a sinistra ● Montage links ● Montage links  <p>PPL1110</p>	<p>PP x1</p> <ul style="list-style-type: none"> ● Montage droite ● Right hand ● Montaje a la derecha ● Montaggio a destra ● Montage rechts ● Montage rechts  <p>PPL1111</p>	<p>QE 140/160/170 x3 100/120 x2</p>  <p>ROU37</p>
<p>PD x1</p>  <p>PPL1080</p>	<p>PE x1</p>  <p>PPL1081</p>	<p>JA x1</p>  <p>AIM36</p>
<p>JD x1</p>  <p>Lg=1894mm J719</p>	<p>QD x1</p>  <p>PGN36</p>	

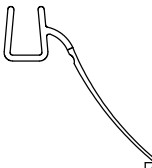
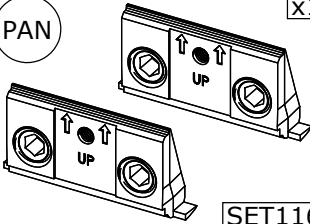
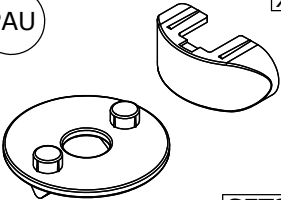
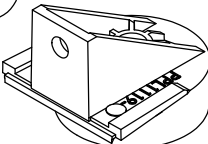
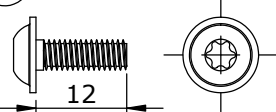
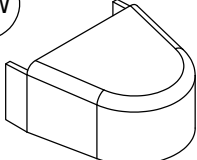
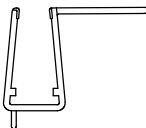
5 PVT

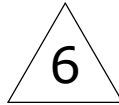
<p>QD x2</p>  <p>PGN36</p>	<p>JR x1</p>  <p>Lg=284mm</p> <p>J761</p>	<p>JS x1</p>  <p>Lg=284mm</p> <p>J762</p>
<p>JT x2</p>  <p>Lg=27mm</p> <p>J763</p>	<p>JV x1</p>  <p>JOI249</p>	<p>JP x2</p>  <p>Lg=1900mm</p> <p>AI074</p>
<p>JU x1</p>  <p>Lg=1940mm</p> <p>J764</p>	<p>PAN x1</p>  <p>SET116</p>	<p>PAU x4</p>  <p>SET29</p>
<p>PAV x2</p>  <p>PPL1119</p>	<p>VR M4 x2</p>  <p>12</p> <p>1=1</p> <p>VIS239</p>	<p>PAW x2</p>  <p>PPL1120</p>
<p>JC x1</p>  <p>Lg=1882mm</p> <p>J723</p>		

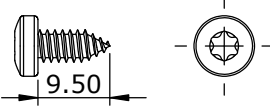
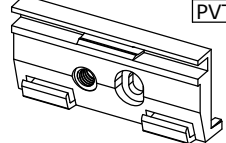
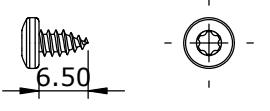
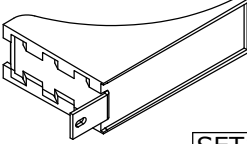
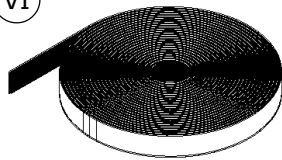
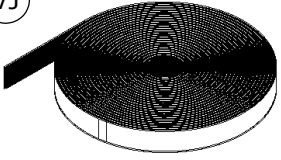
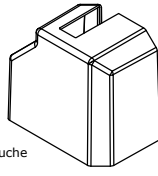
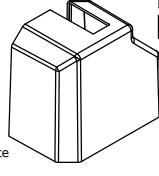
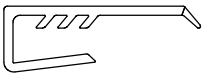
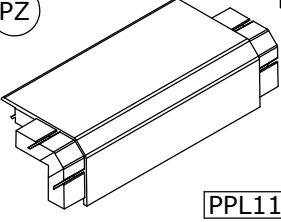

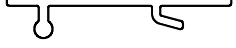
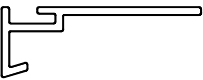
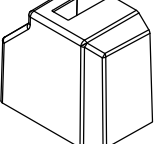
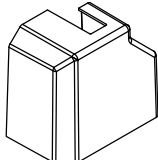
<p>VQ $\varnothing 4.2$ x6</p>  <p>9.50</p> <p>1=1 VIS238</p>	<p>PF CLT/SOLO:140/160/170 x4 CLT/SOLO:100/120 x3 PVT x0</p>  <p>PPL1099</p>	<p>VO $\varnothing 3.5$ x12</p>  <p>6.50</p> <p>1=1 VIS253</p>
<p>PAK 140/160/170 x8 100/120 x6</p>  <p>SET105</p>	<p>VI x3</p>  <p>Lg=2800mm VEL06-5</p>	<p>VJ x3</p>  <p>Lg=2800mm VEL06-6</p>
<p>SE CLT x1 PVT x0</p>  <p>● Montage gauche ● Left hand ● Montaje a la izquierda ● Montaggio a sinistra ● Montage links ● Montage links</p> <p>SUP166</p>	<p>SF CLT x1 PVT x0</p>  <p>● Montage droite ● Right hand ● Montaje a la derecha ● Montaggio a destra ● Montage rechts ● Montage rechts</p> <p>SUP167</p>	<p>JJ x2</p>  <p>Lg=2200mm PFL84</p>
<p>PZ x1</p>  <p>PPL1132</p>	<p>AE x1</p>  <p>Lg=2030mm 6195-01</p>	<p>AF x1</p>  <p>Lg=1005mm 6195-02</p>
<p>AH x2</p>  <p>Lg=1998mm 6197-01</p>	<p>SO ● Montage gauche ● Left hand ● Montaje a la izquierda ● Montaggio a sinistra ● Montage links ● Montage links</p> <p>PVT x1 CLT x0</p>  <p>SET117</p> <p>● Montage droite ● Right hand ● Montaje a la derecha ● Montaggio a destra ● Montage rechts ● Montage rechts</p> <p>x1</p> 	

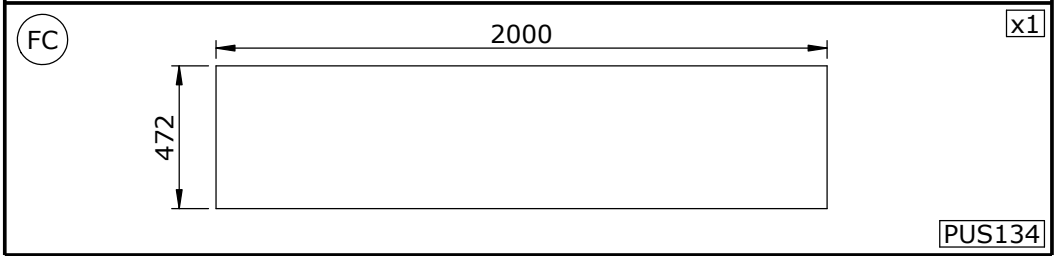
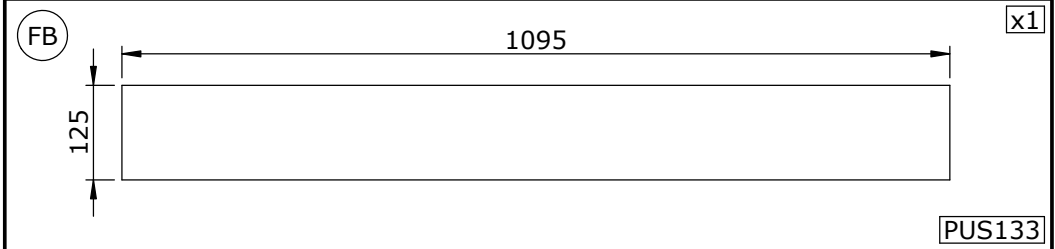
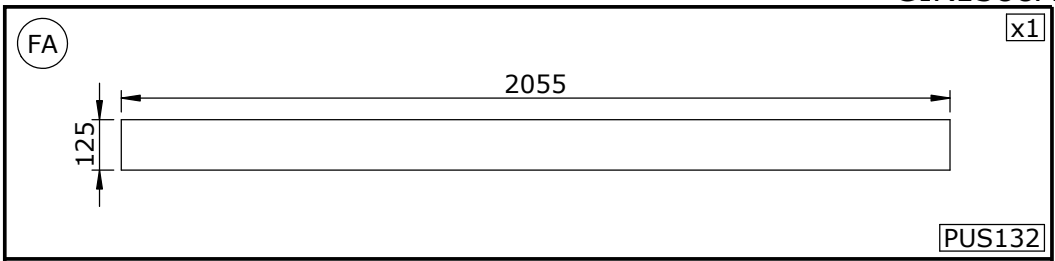

- Les quantités données sont les quantités utiles au montage. les sachets fournis contiennent des pièces supplémentaires.
 - The quantities given are what are required for the installation. There may be some surplus in the package provide.
- Las cantidades indicadas son las cantidades necesarias para el montaje. Las bolsitas incluidas contienen piezas suplementarias.
 - Le quantità fornite sono le quantità necessarie al montaggio. I sacchetti forniti contengono pezzi supplementari.
 - De aangegeven aantallen zijn vereist voor de montage. De verpakking bevat extra onderdelen.
- Die Mengenangaben beziehen sich auf die für die Montage nötigen Teile. Eventuell weitere beige packte Teile ignorieren.

● Outillage nécessaire ● Tools required ● Equipamiento necesario
 ● Attrezzatura necessaria ● Benodigde gereedschap ● Werkzeuge erforderlich

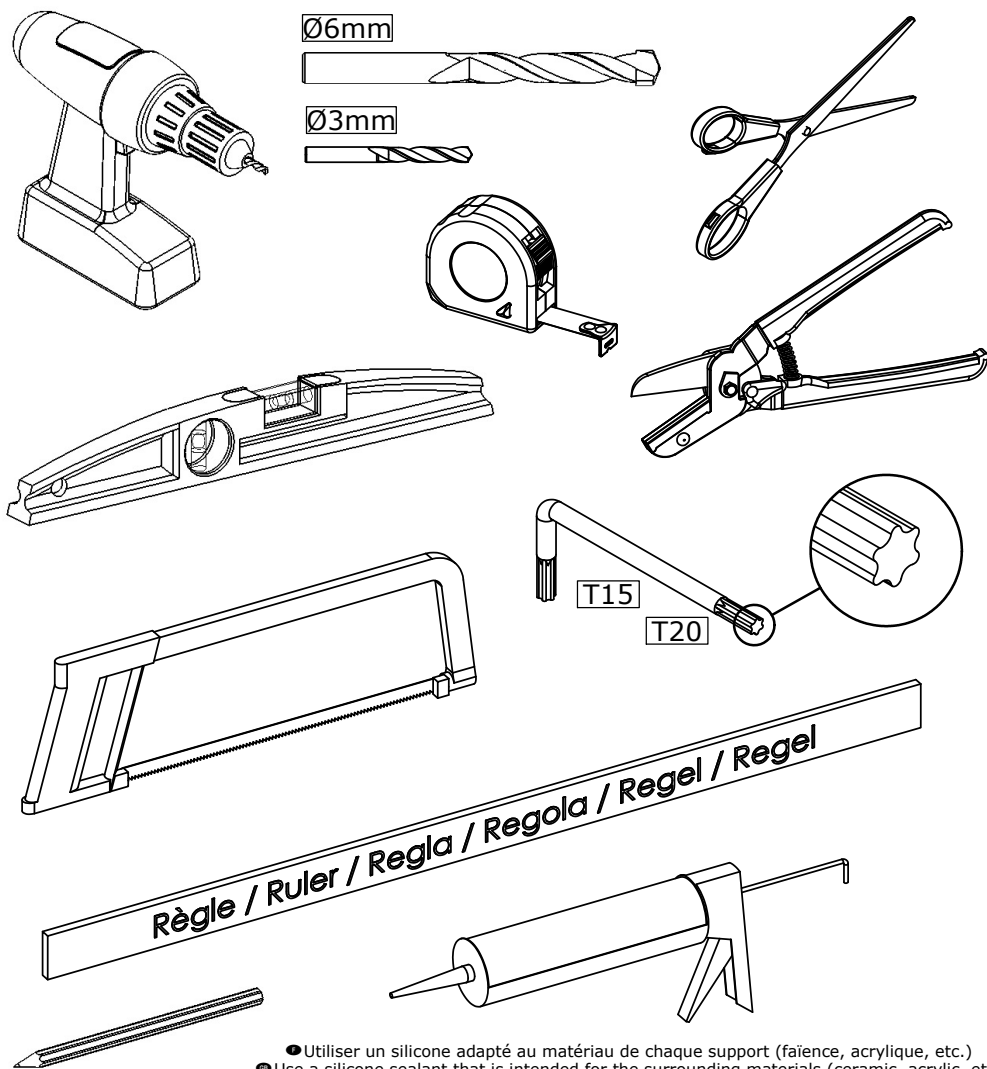

- Utiliser un silicone adapté au matériau de chaque support (faïence, acrylique, etc.)
- Use a silicone sealant that is intended for the surrounding materials (ceramic, acrylic, etc.)
 - Usar una silicona adecuada para cada tipo de material (loza, acrílico, etc.)
 - Utilizzare un silicone adatto a qualsiasi materiale (ceramica, acrilico, ecc.)
 - Gebruik siliconenkit die geschikt is voor iedere ondergrond (tegelwerk, acryl, etc.)
 - Für das jeweilige Trägermaterial (Stein, Acryl usw.) geeignetes Silikon verwenden.



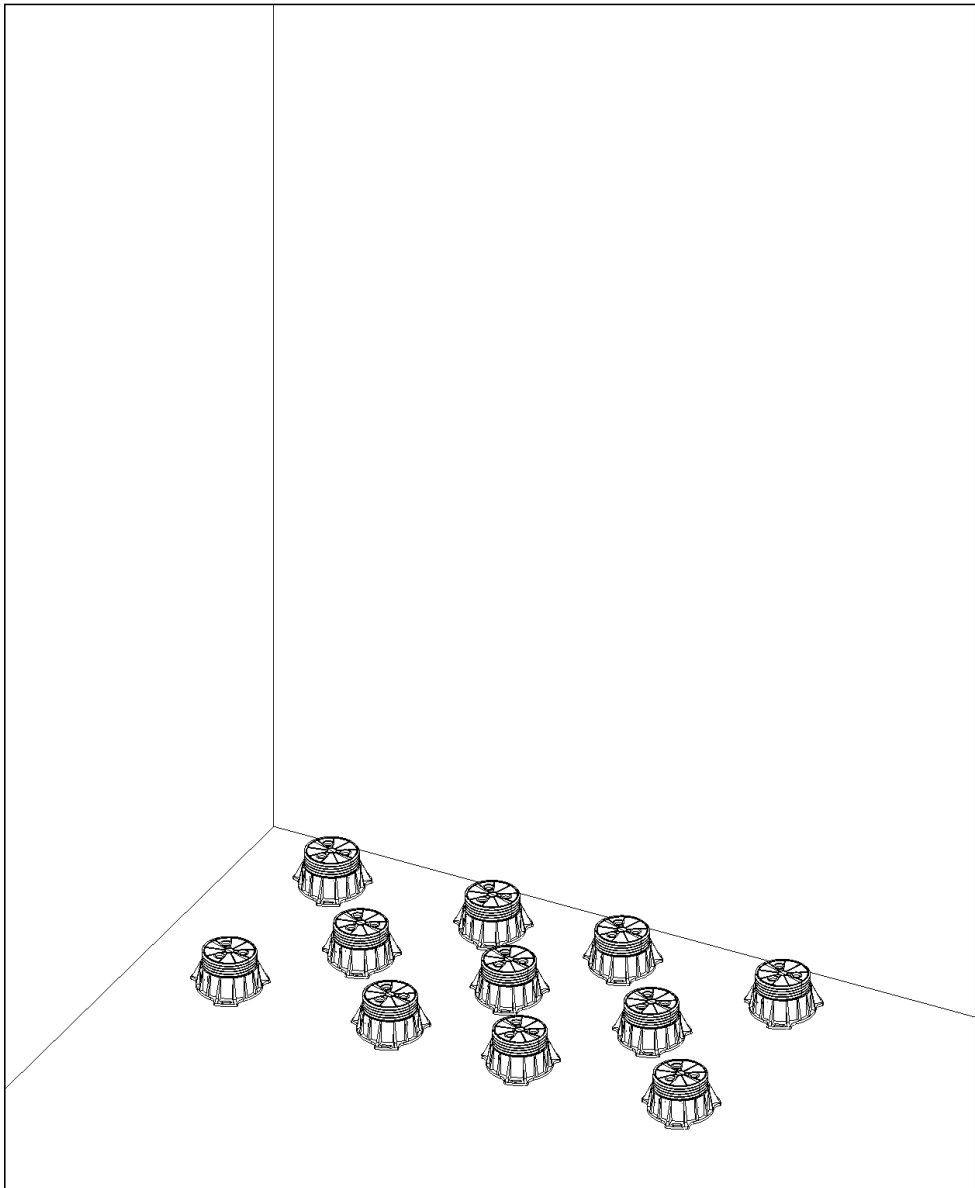
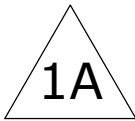

1B

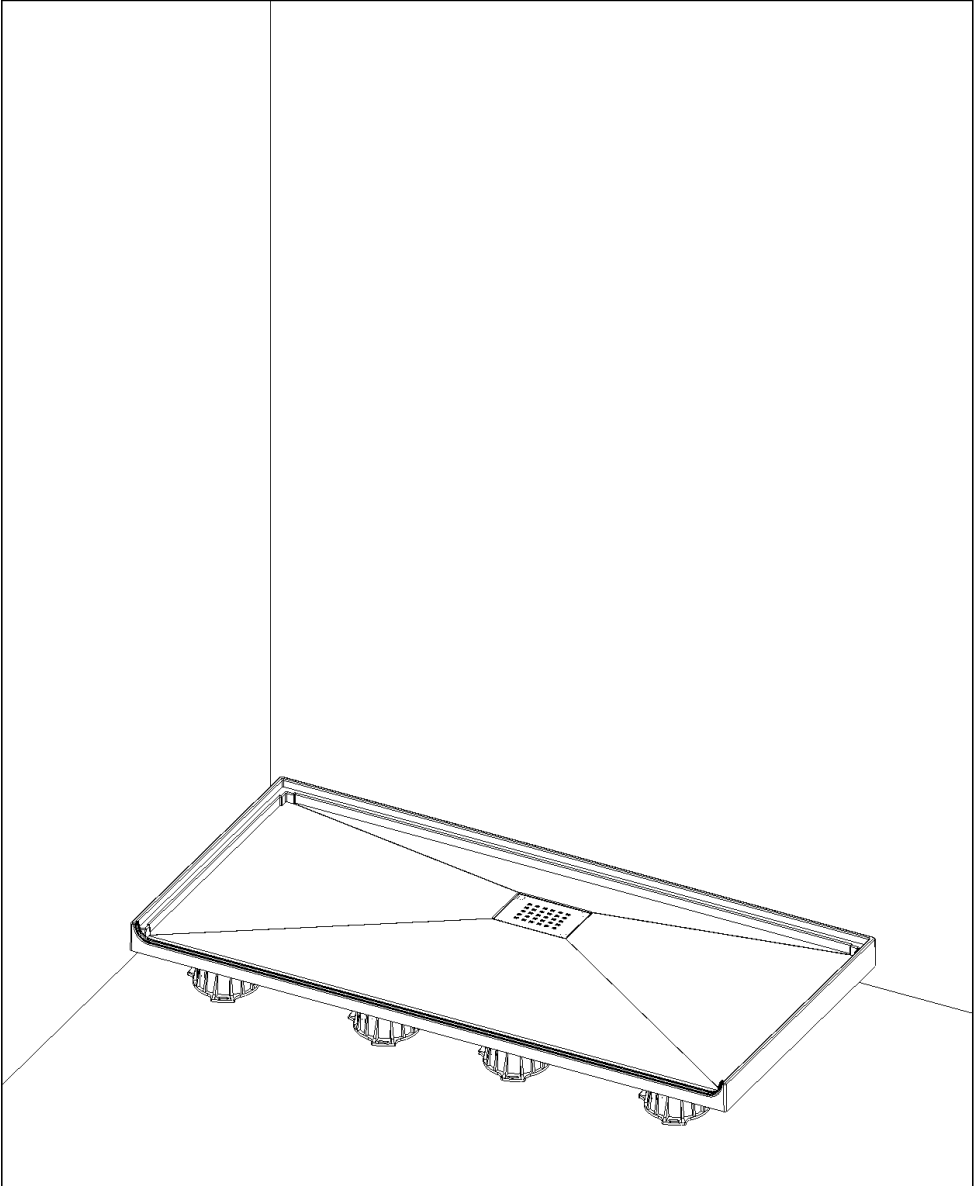

1C

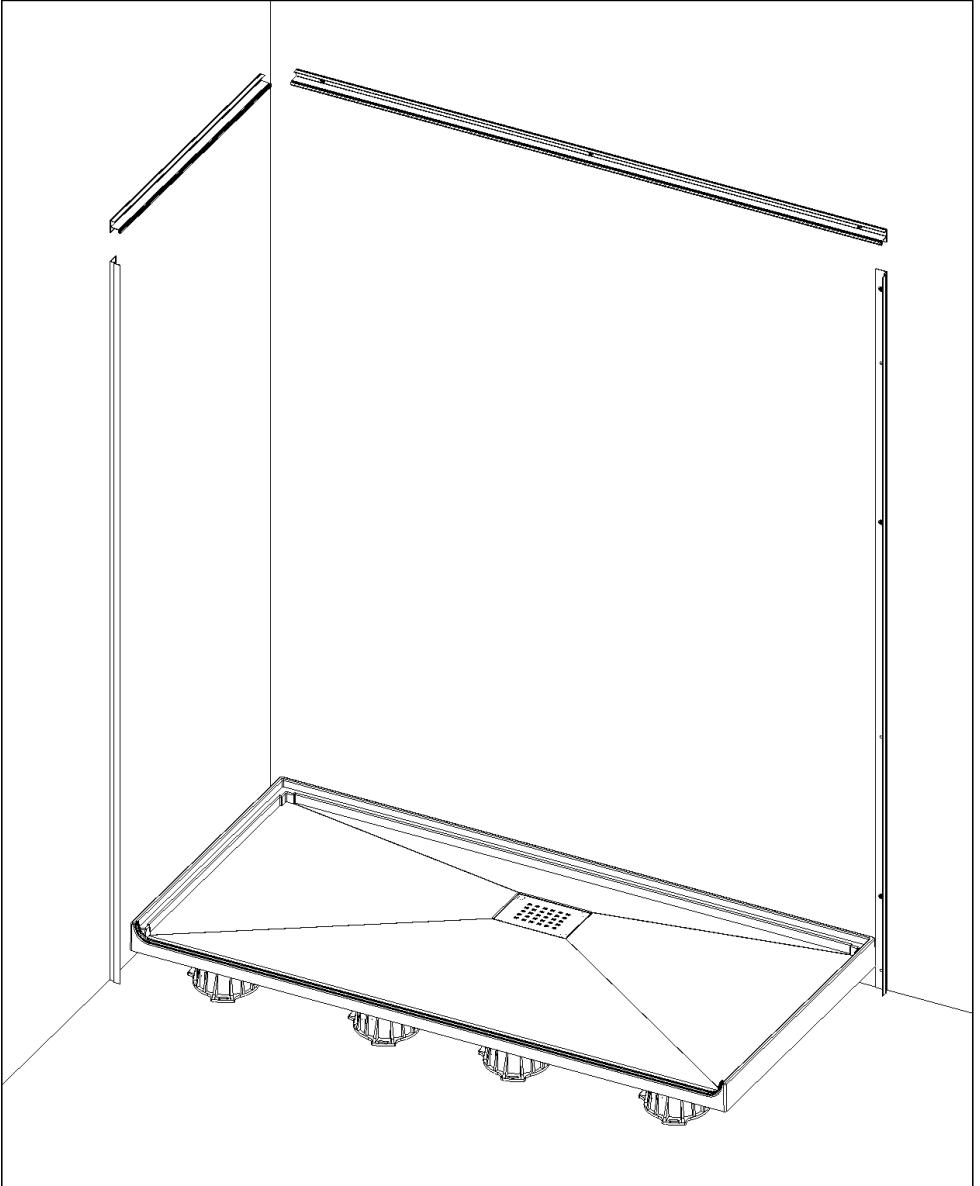

2

2

2C

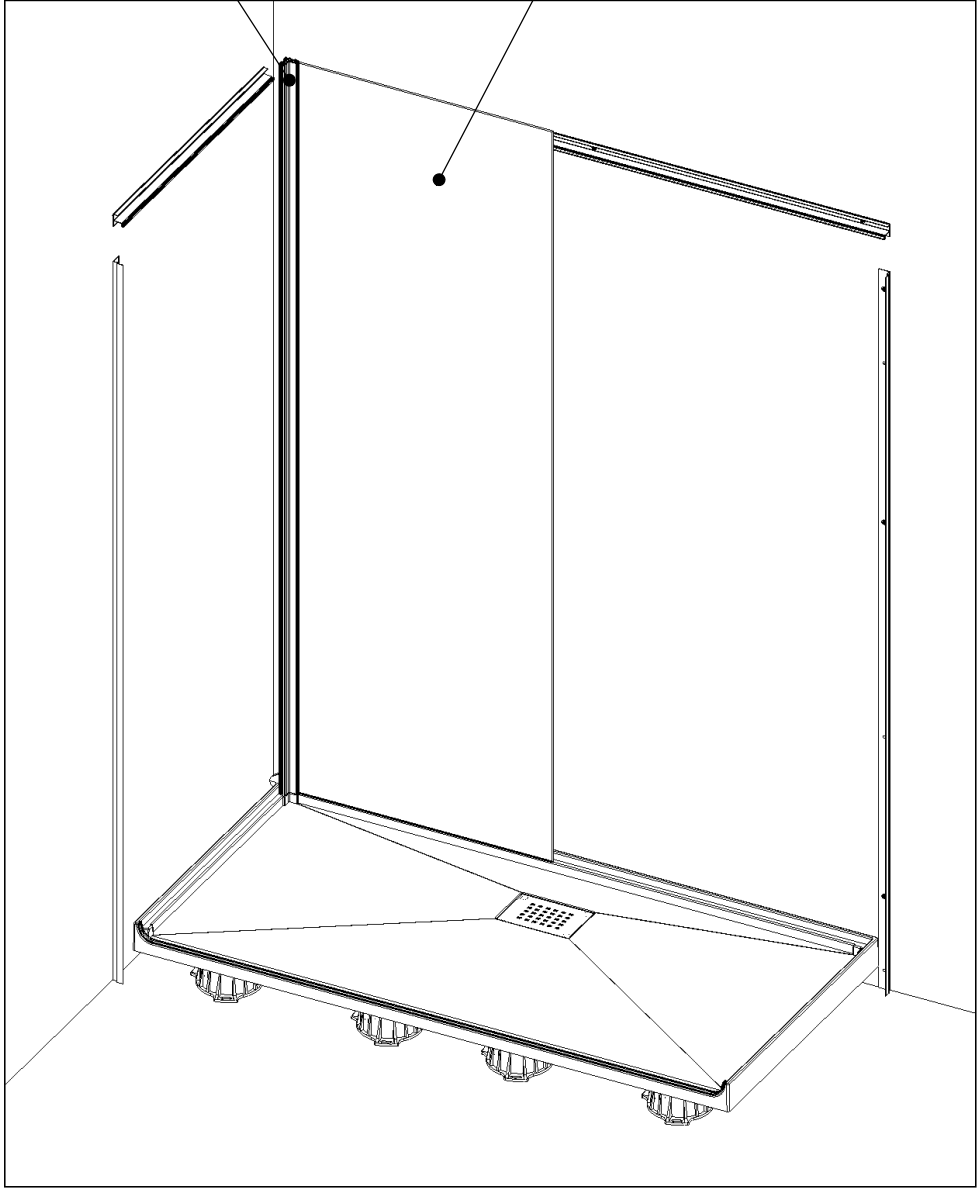

2

2

2B

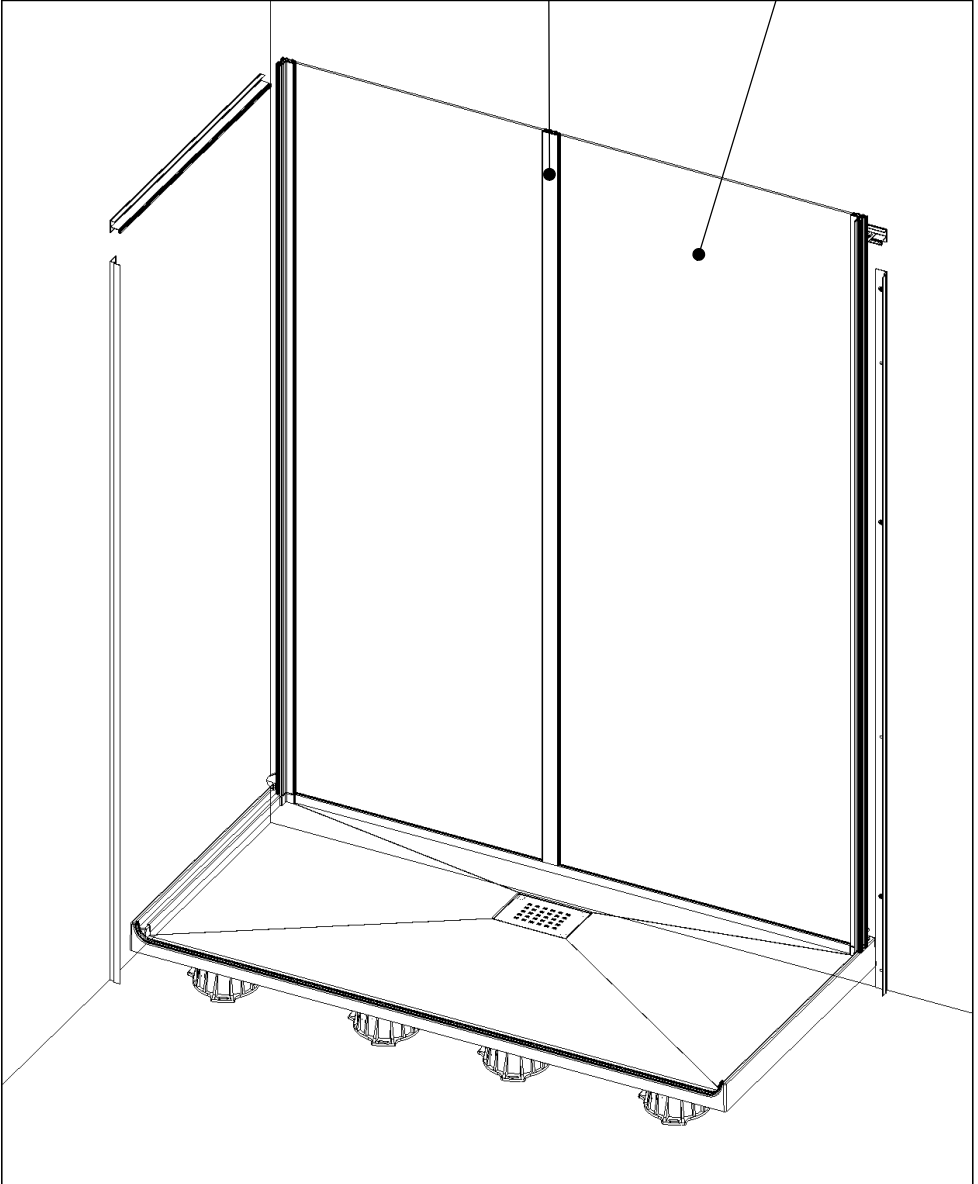

2

2A

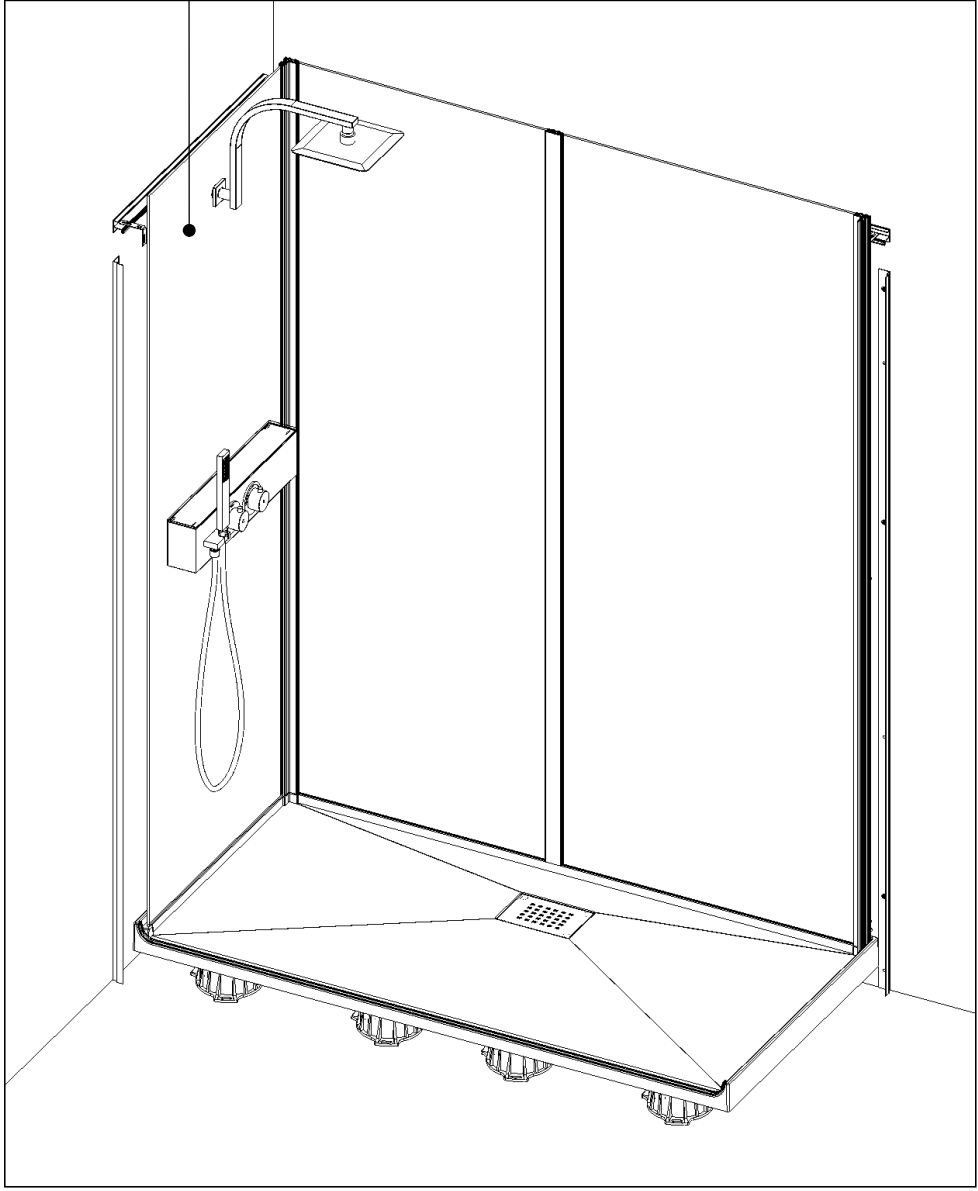

3

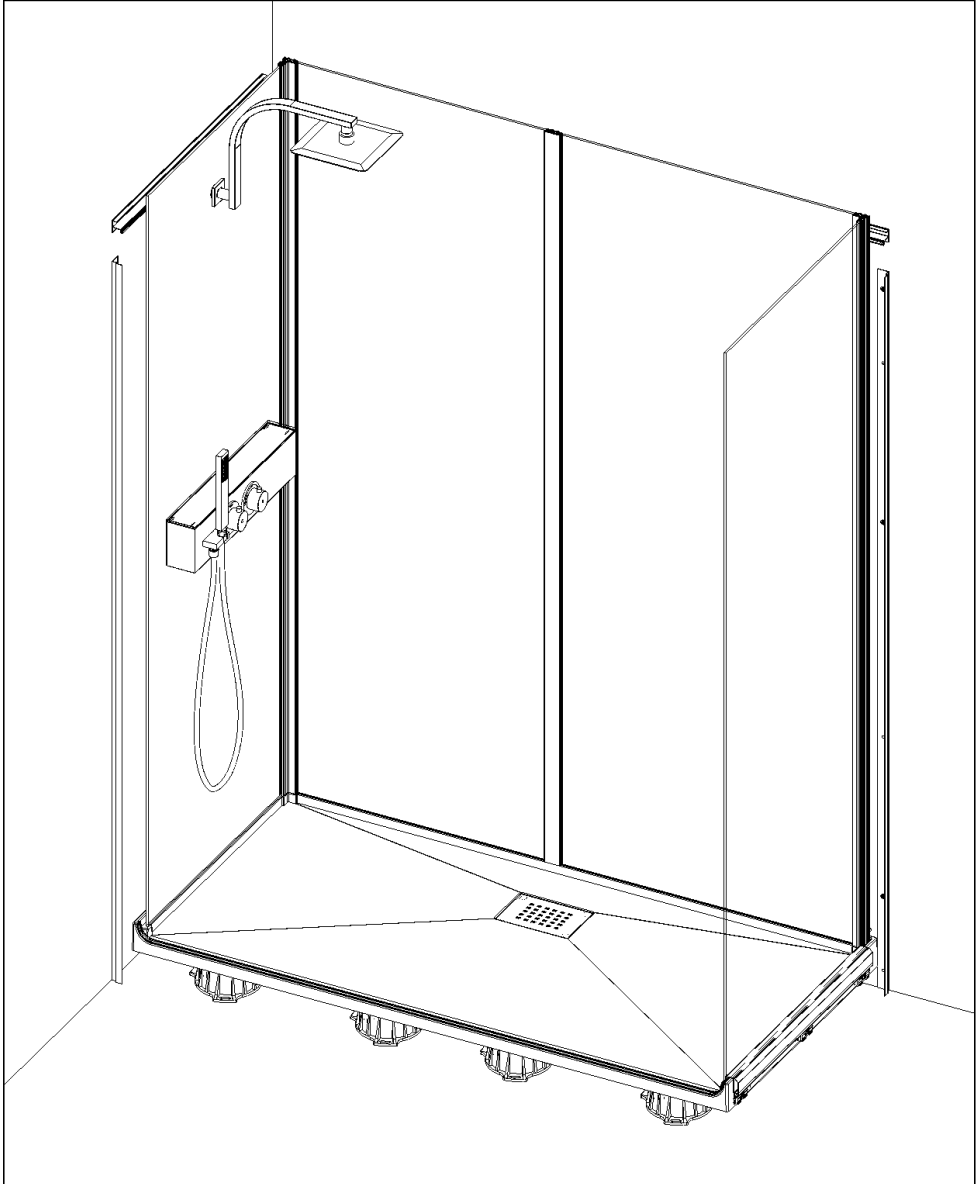

4

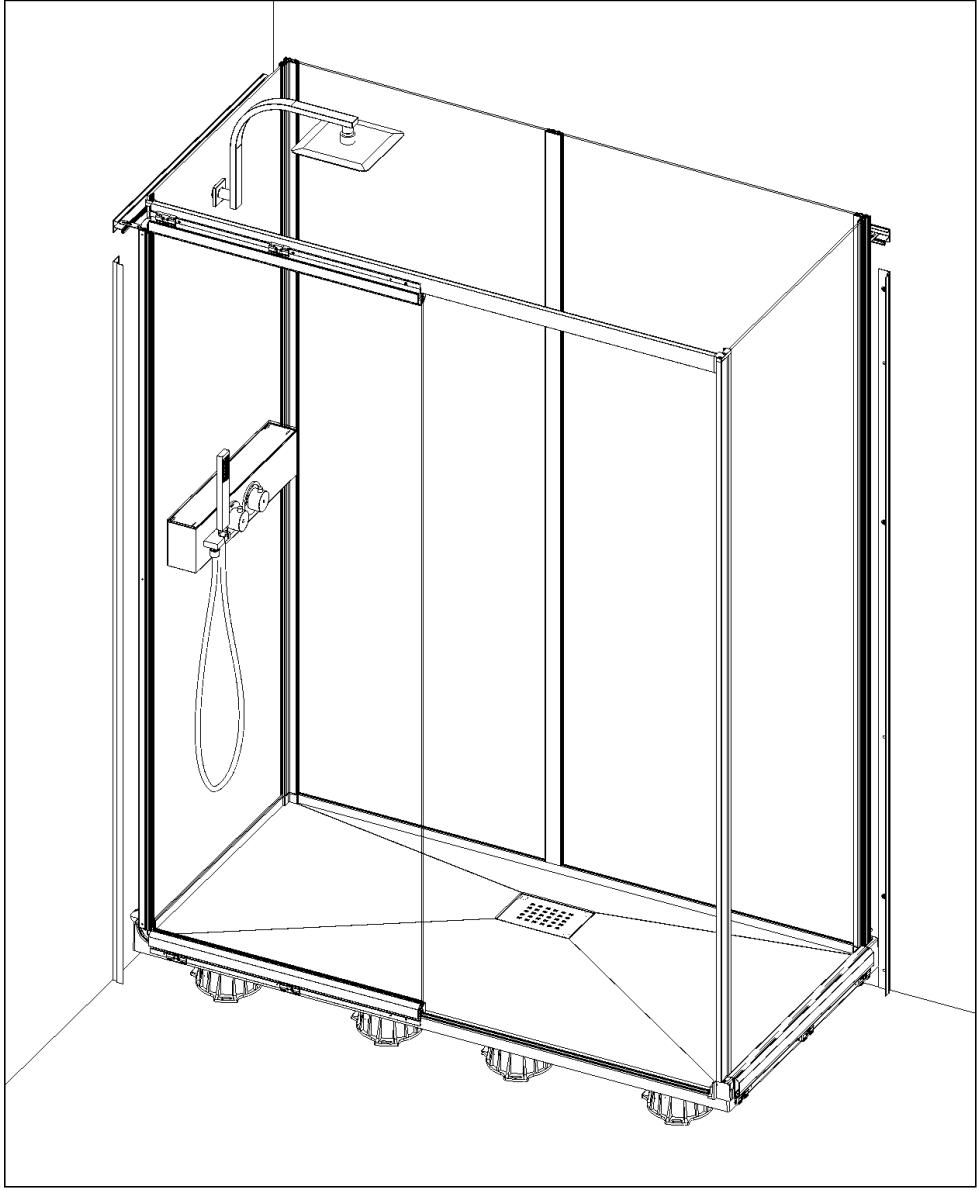

- En cas de montage solo ● In case of mounting without door
- En caso de montaje con mampara fija
- In caso di montaggio senza porta
- Bij montage uitvoering solo ● Bei Montage Ohne Tür

=>

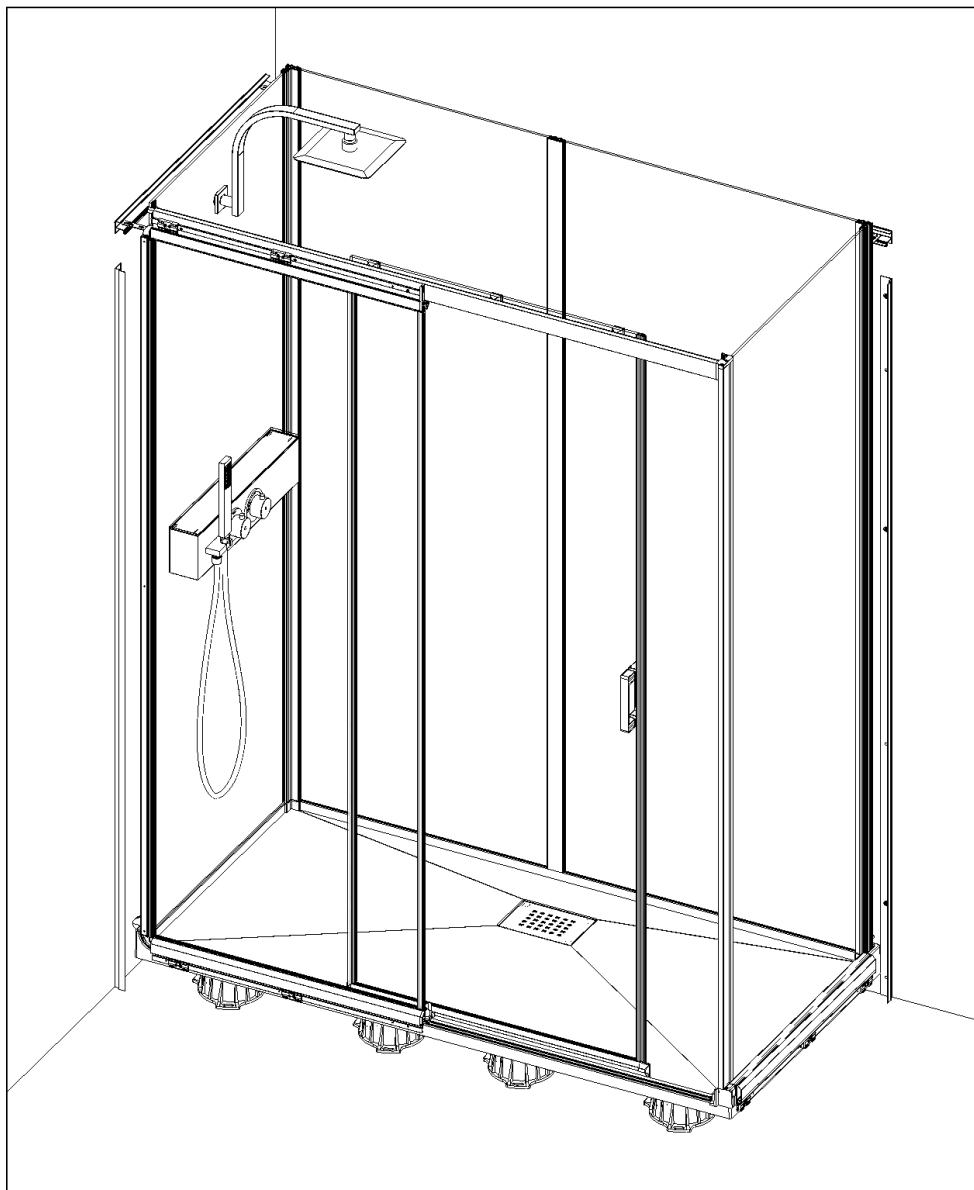

- ① En cas de montage solo ② In case of mounting without door
- ③ En caso de montaje con mampara fija
- ④ In caso di montaggio senza porta
- ⑤ Bij montage uitvoering solo ⑥ Bei Montage Ohne Tür

=>

6

5

PVT



6

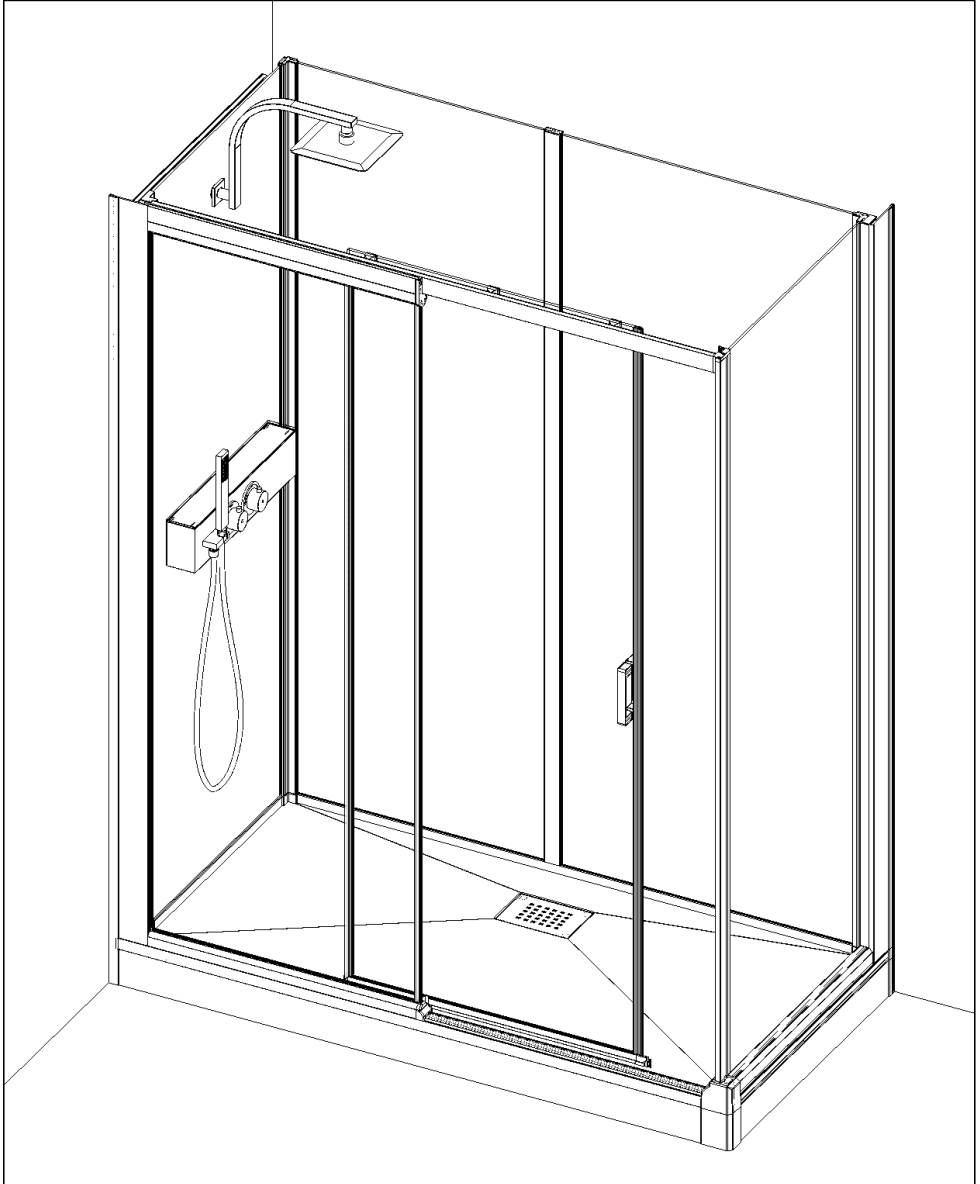

- Zone de décaissement pour un montage de receveur sans pieds
- Area required for the installation of the tray without feet
- Zona rebajada para la instalación del plato sin pies
- Zone necessarie per un montaggio del piatto senza piedi
- Aflooplegebied voor de montage van een douchebak zonder poten
- Freier Raum für Montage der Duschanne ohne FüÙe

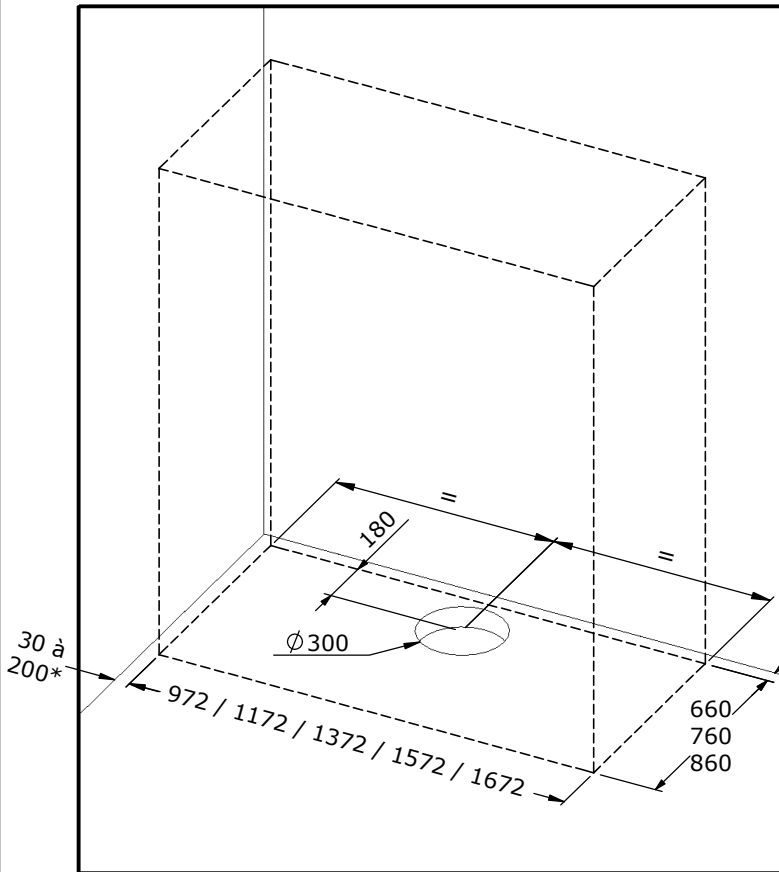

- * ● Côté gauche et droit cumulés ne peuvent excéder 385 mm.
- Left and right sides summed must not exceed 385 mm.
- Las cuotas agregadas izquierda y derecha no pueden superar 385 mm.
- Sinistra e destra combinati non possono superare 385 mm.
- De linker- en rechterzijde mogen samen niet groter zijn dan 385 mm.
- Links und rechts dürfen es zusammen nicht mehr als 385 mm sein.

● Cotes en mm ● Dimensions in mm ● Cotas en mm

● Quote in mm ● Afmetingen in mm ● Maße sind in mm angegeben

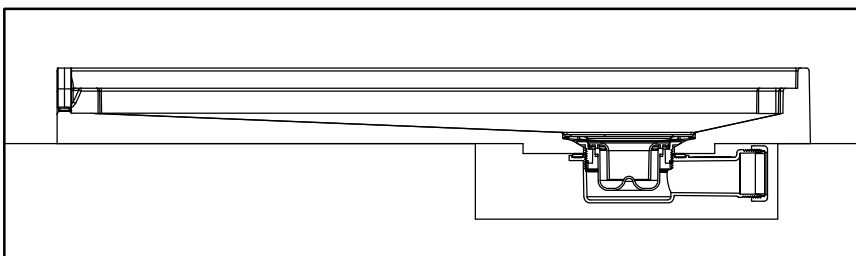



SAV
SERVICE HELPLINES
ASSISTENZA POST-VENDITA
SERVICIO POSTVENTA

FRANCE

02 40 21 29 45

SCHWEIZ

(01) 748 17 44

UK

020 8842 0033

ESPANA

93 544 60 76

IRELAND

04697 33102

NEDERLAND

+31 475 487 100

DEUTSCHLAND

+49 (0) 6074 / 30928 0

BELGIE

+31 475 487 100

ITALIA

(0382) 6181

BELGIQUE

+31 475 487 100

OSTEREICH

+43 1 710 60 70

РОССИЯ

963 19 40, 773 67 22