

- F Notice de montage
- GB Installation instructions
- E Manual de instalación
- I Istruzioni di montaggio
- NL Montage-instructies
- D Montageanleitung

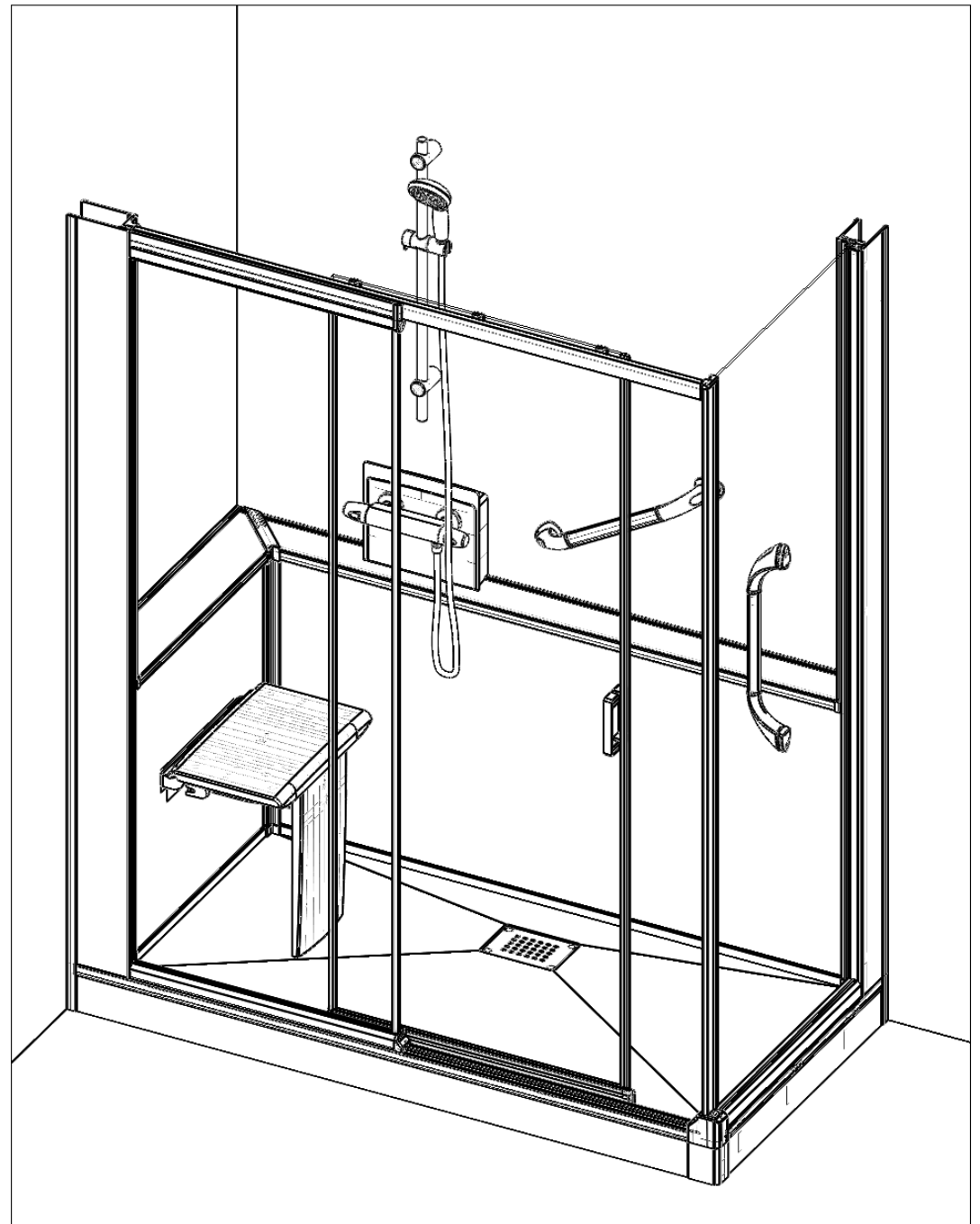

- Attention aux étapes :
- GB Check installation steps :
- E Atención a los pasos : P. 2 - 11
- ● Attenzione ai passi :
- NL Aandacht voor de stappen :
- D Achtung vor den Schritten :

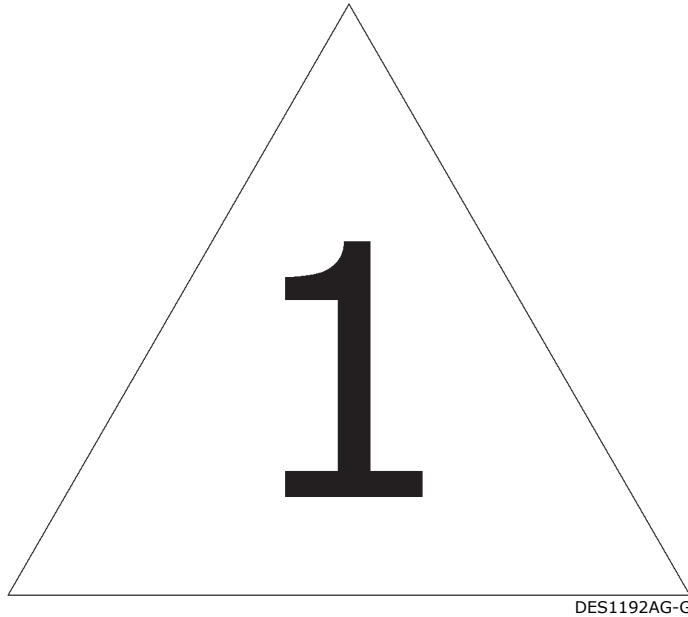

● **NOUVEAUTÉ** : Le joint d'étanchéité est désormais pré-positionné en usine. Collez-le sur toute sa longueur avant montage.

● **NEW** : The seal is now pre-positioned at the factory. Paste it along its entire length before mounting.

● **NUEVO** : El sello ahora está preposicionada en la fábrica. Pégalo en toda su longitud antes del montaje.

● **NUOVO** : Il sigillo è ora pre-posizionato in fabbrica. Incollalo per tutta la sua lunghezza prima di montarlo.

● **NIEUW** : De afdichting is nu vooraf gepositioneerd in de fabriek. Plak het over de gehele lengte voordat u het monteert.

● **NEU** : Die Dichtung ist jetzt werkseitig vorpositioniert. Fügen Sie es vor der Montage über die gesamte Länge ein.

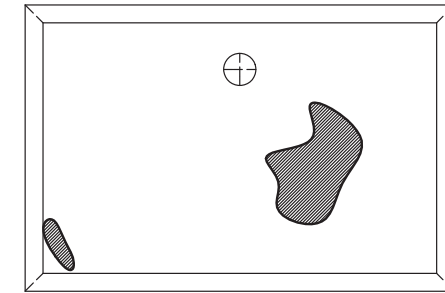

● D'éventuelles irrégularités de surface sur le dessous de votre receveur n'empêchent pas une installation conforme aux préconisations de pose. La colle (type MAP, polyuréthane ou MS polymère) comblera facilement ces manques lors du collage.

● Any surface irregularities on the underside of the shower tray have no influence on the installation according to the installation recommendations. The adhesive (adhesive mortar, polyurethane or MS polymer) compensates for these unevenness when bonding the feet off without any problems.

● Posibles irregularidades de la superficie en la parte inferior del receptor no impida la instalación de acuerdo con las recomendaciones de instalación. El adhesivo (tipo mortero flexible, poliuretano o polímero MS) rellenará fácilmente estos huecos al pegar los pies.

● Eventuali irregolarità della superficie nella parte sotto della doccia non impediscono l'installazione in base alle raccomandazioni di montaggio. La colla (tipo map, poliuretano o MS polimero) riempirà facilmente queste lacuna quando si incollano i piedini.

● Eventuele onregelmatigheden in de vlakke onderzijde van uw douchebak vormen geen belemmering voor een installatie conform aan de gestelde richtlijnen. De lijm (type MAP, polyurethaan of MS-polymeer) vult eventuele openingen makkelijk op tijdens het lijmen.

● Eventuelle Unregelmäßigkeiten der Oberfläche an der Unterseite Ihrer Duschwanne haben keinen Einfluss auf die Installation gemäß den Einbauempfehlungen. Der Klebstoff (Typs MAP, Polyurethan oder MS-Polymer) gleicht diese Unebenheiten beim Verkleben problemlos aus.



● Aspirer le dessous de votre receveur avant la pose

● Vacuum the bottom of the shower tray before installation

● Aspirar la parte inferior de su plato de ducha antes de instalarlo

● Aspirare la parte sottostante del piatto doccia prima dell'installazione

● Stofzuig de bodem van de douchebak voor de installatie

● Saugen Sie den Boden der Duschwanne vor der Installation ab



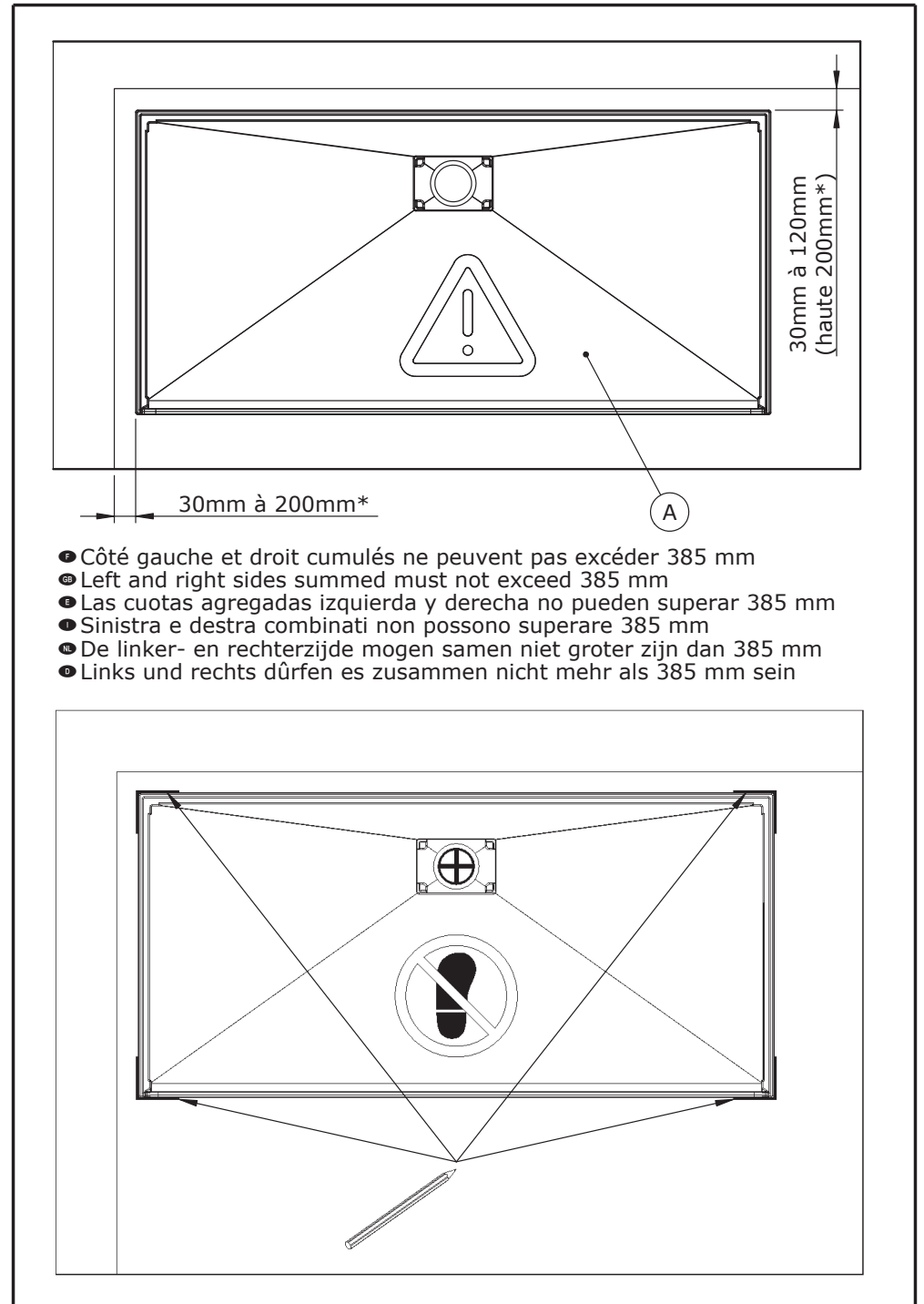
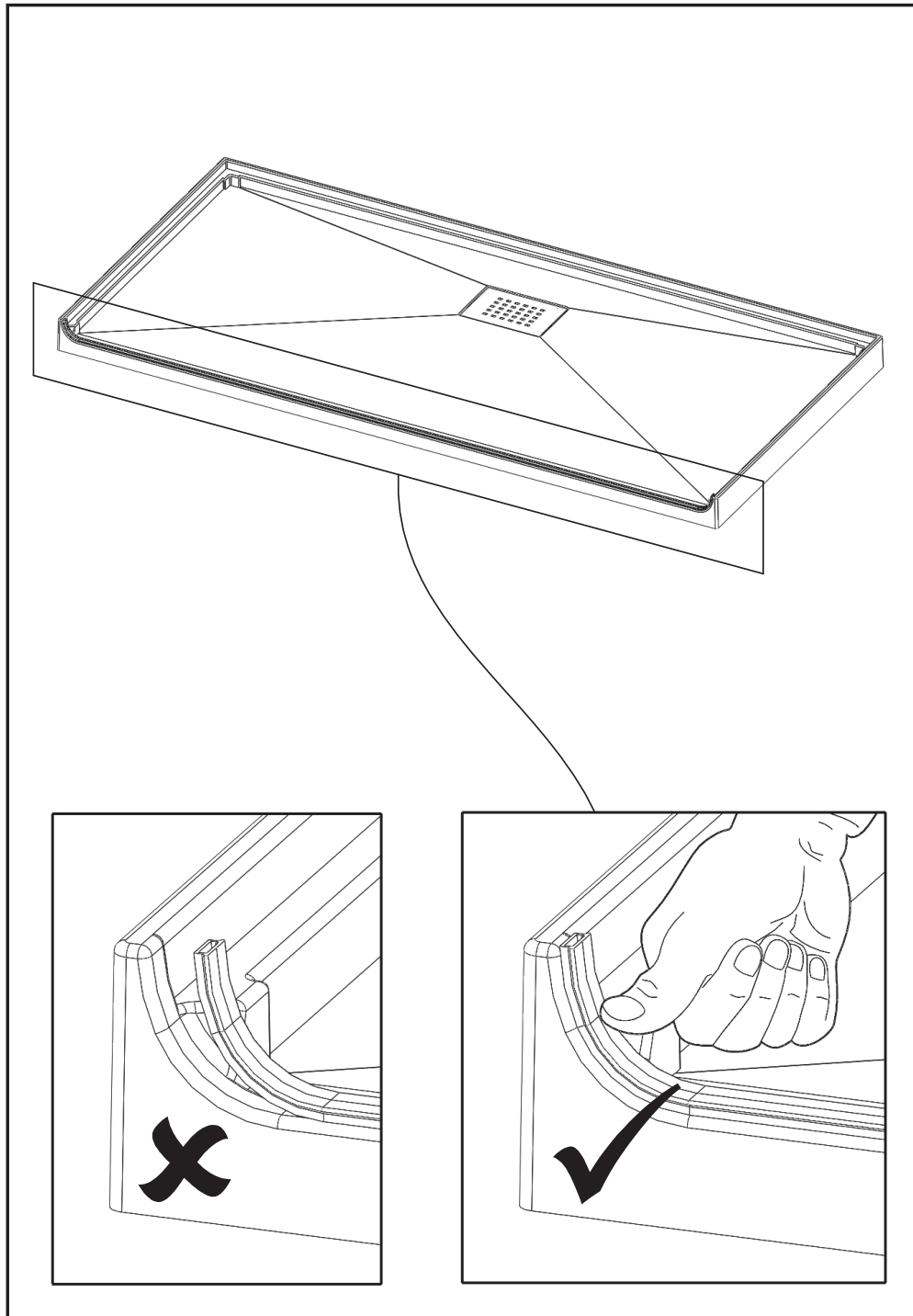

100

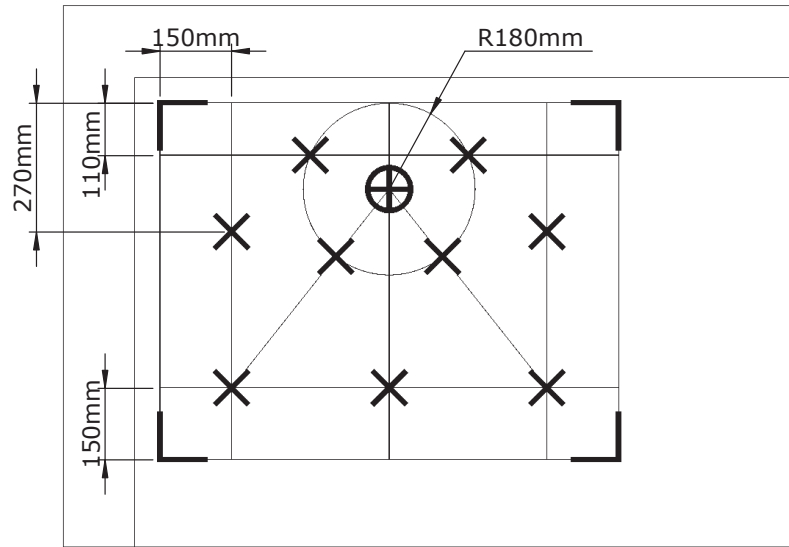

120 / 140 / 160 / 170

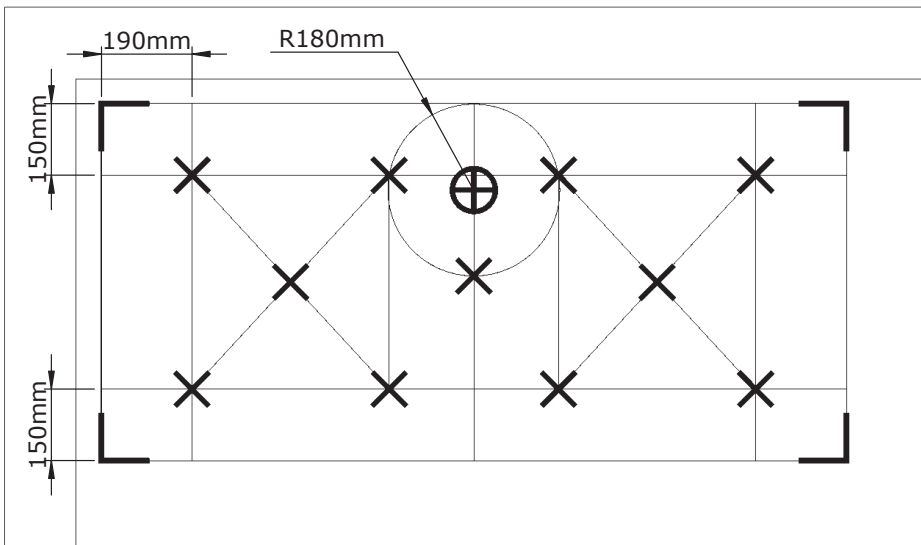

- Pose de receveur avec pieds ● Laying the tray with adjustable feet
- Instalación del plato con pies ● Posa del piatto con piedi
- Montage van douchebak op poten ● Installation der duschwanne mit Füßen

- Colle polyuréthane
- Polyurethane adhesive
- Pegamento de poliuretano
- Adesivo poliuretano
- Polyurethaan kit
- Polyurethan-klebstoff

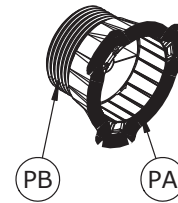
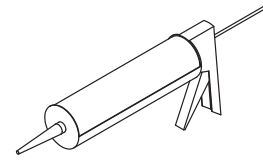

60mm à 110mm

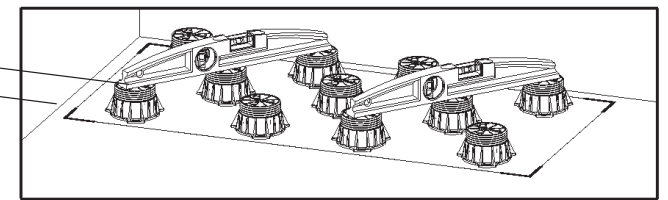
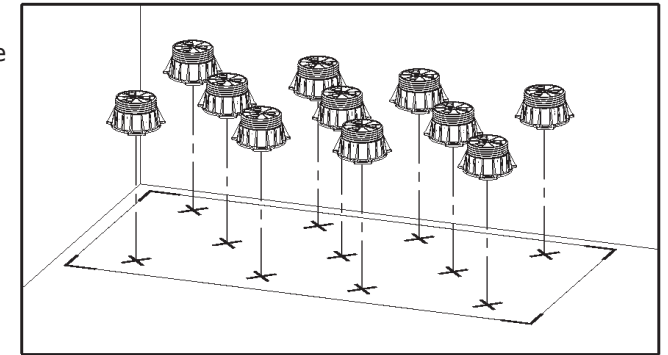

- Pose de receveur sans pieds ● Laying the tray without feet
- Instalación del plato sin pies ● Posa del piatto senza piedi
- Montage van douchebak zonder poten ● Installation der duschwanne ohne Füßen

- Colle polyuréthane
- Polyurethane adhesive
- Pegamento de poliuretano
- Adesivo poliuretano
- Polyurethaan kit
- Polyurethan-klebstoff

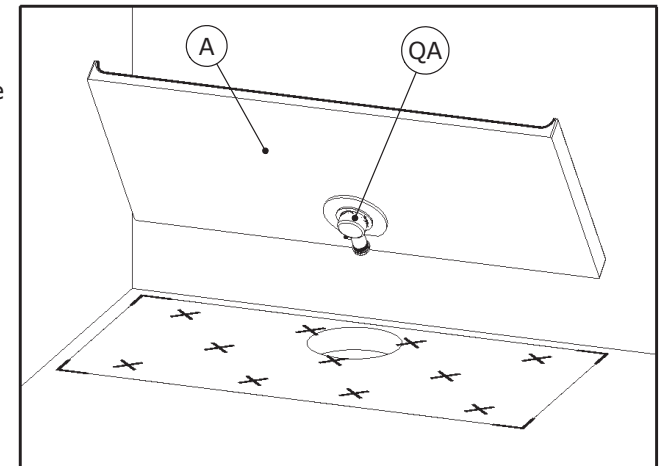
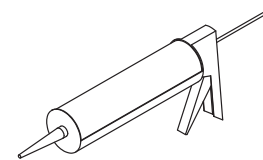



- Vérifier que tous les pieds soient bien en contact avec le receveur
- Check that all feet are in contact with the shower tray
- Compruebe que todos los pies están en contacto con el plato de ducha
- Controllare che tutti i piedi sono in contatto con il piatto doccia
- Controleer of alle voeten in contact staan met de douchebak
- Prüfen, ob alle Füße sind in Kontakt mit der Duschwanne

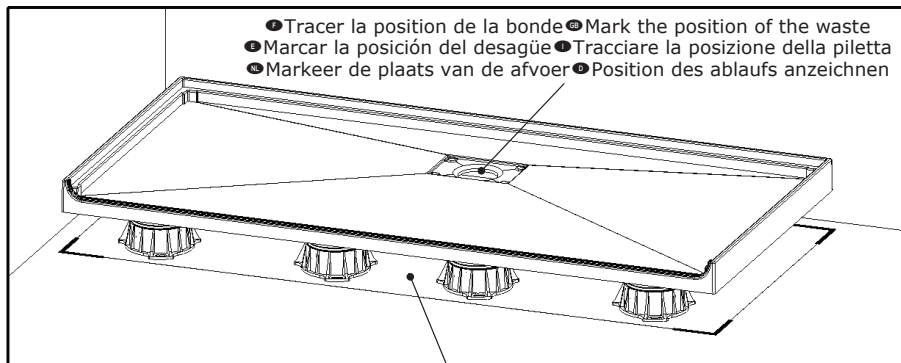

- Tracer la position de la bonde
- Mark the position of the waste
- Marcar la posición del desagüe
- Tracciare la posizione della piletta
- Markeer de plaats van de afvoer
- Position des ablaufs anzeichnen

- Sol rigide et non-humide indispensable
- Ensure a solid dry surface
- Suelo rígido y sin humedad imprescindible
- Il suolo deve essere ben asciutto e non umido
- De ondergrond moet volkomen vlak en droog zijn
- Untergrund muss fest und darf nicht feucht sein

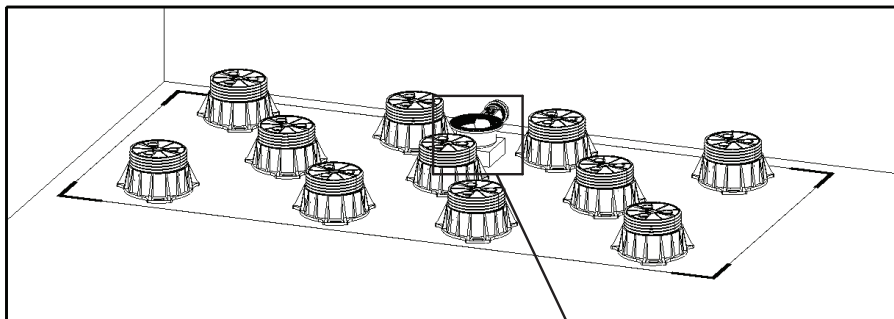

- Raccorder votre évacuation à la bonde
- Connect the waste pipe
- Conectar el tubo de evacuación al sumidero
- Collegare il tubo di evacuazione alla piletta
- Sluit de afvoer aan op het afvoerputje
- Das abflussrohr an den ablauf anschließen

QA

- Cale en bois si nécessaire
- Provide support if necessary
- Soporte de madera en caso necesario
- Supporto in legno, se necessario
- Gebruik eventueel een houten blokje
- Ggf. holzklotz vorsehen

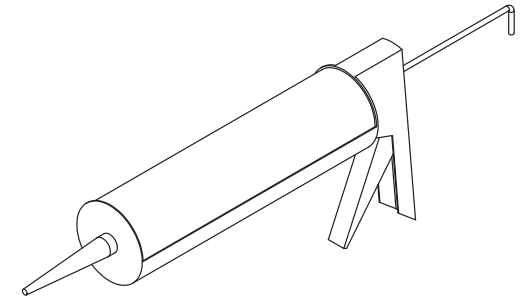
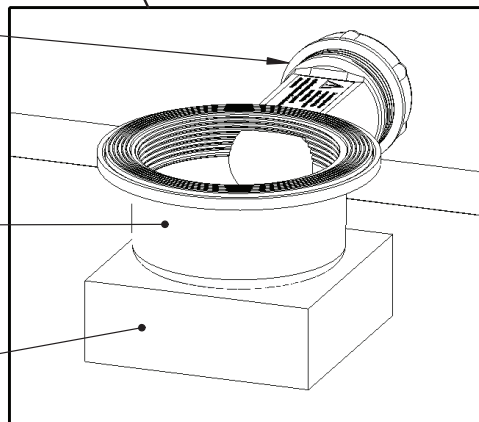

- Colle polyuréthane
- Polyurethane adhesive
- Pegamento de poliuretano
- Adesivo poliuretano
- Polyurethaan kit
- Polyurethan-Klebstoff

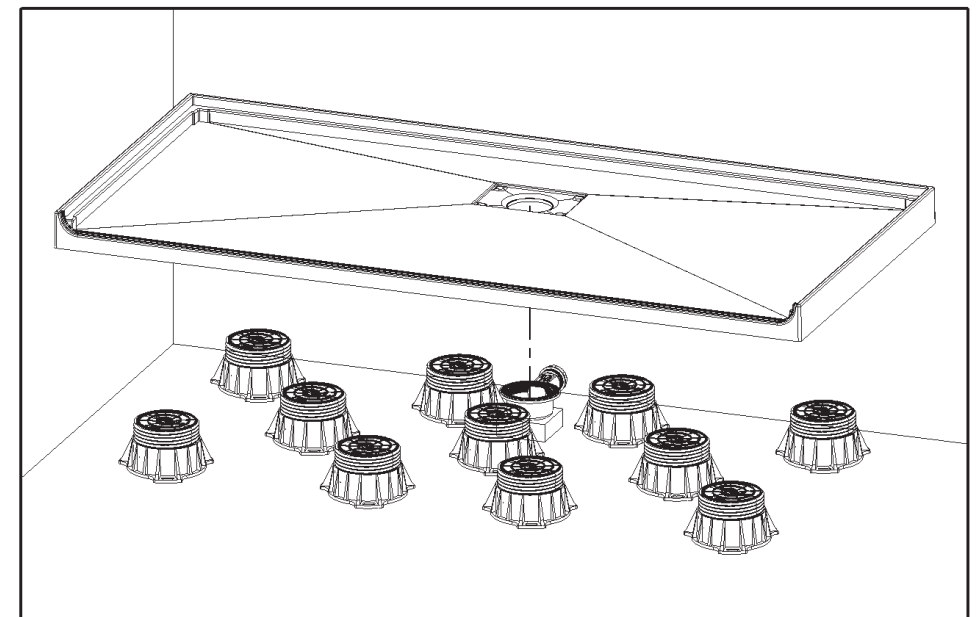
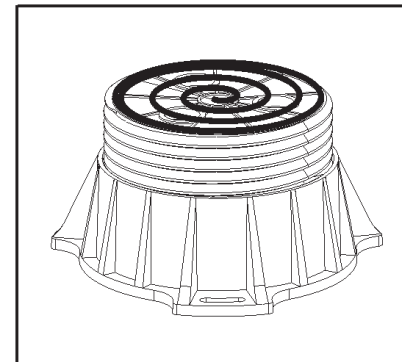

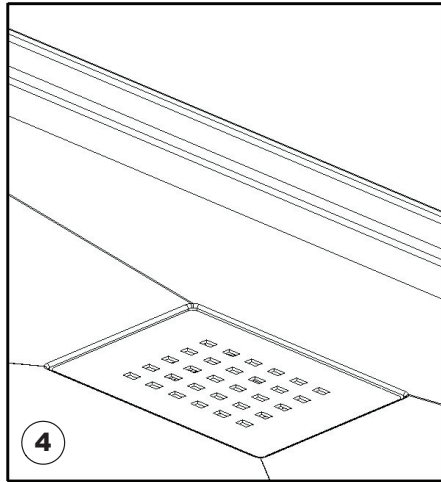
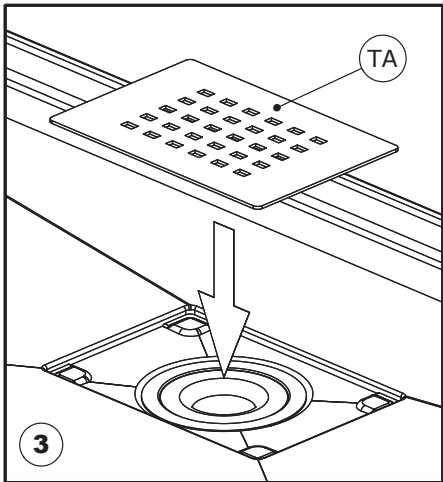
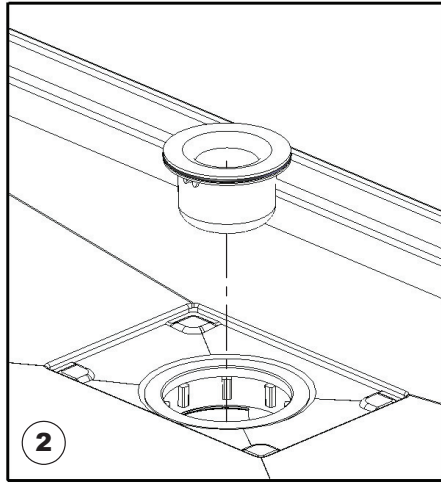
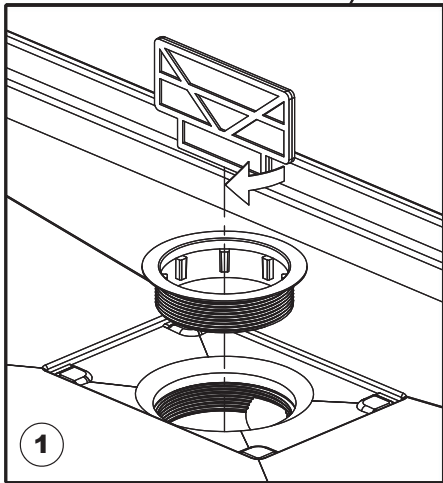
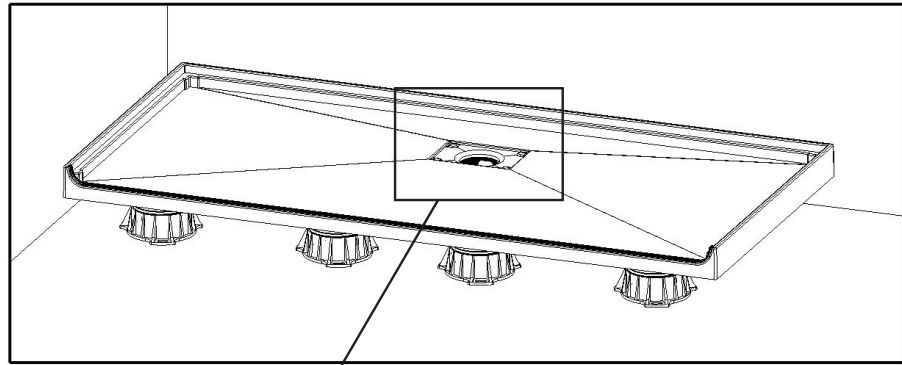

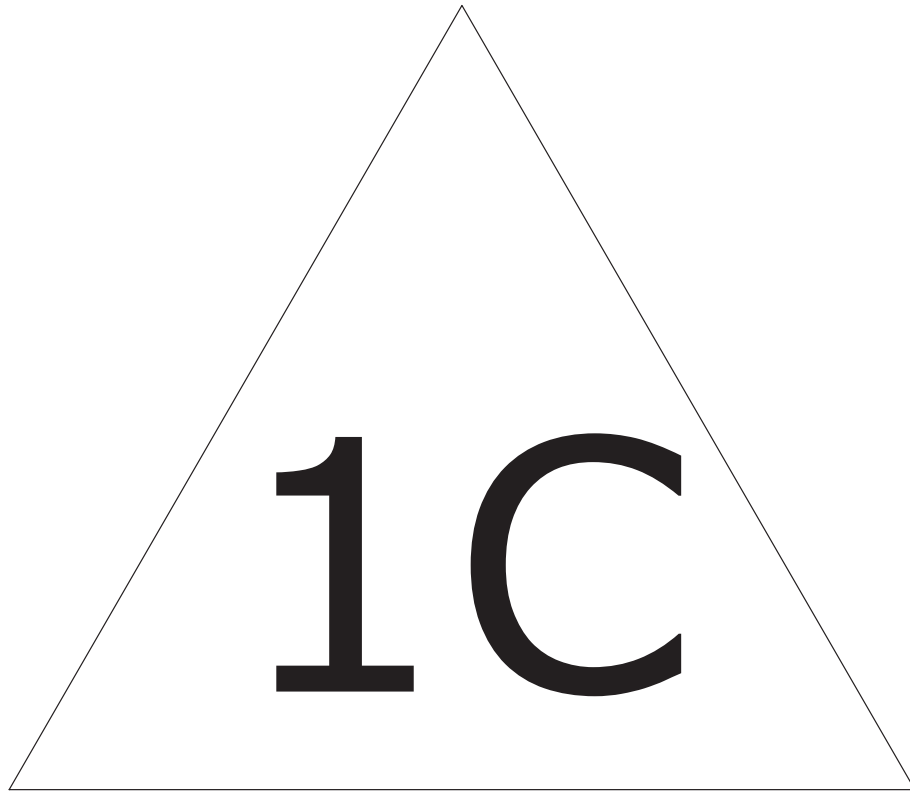

DES1228AG-C

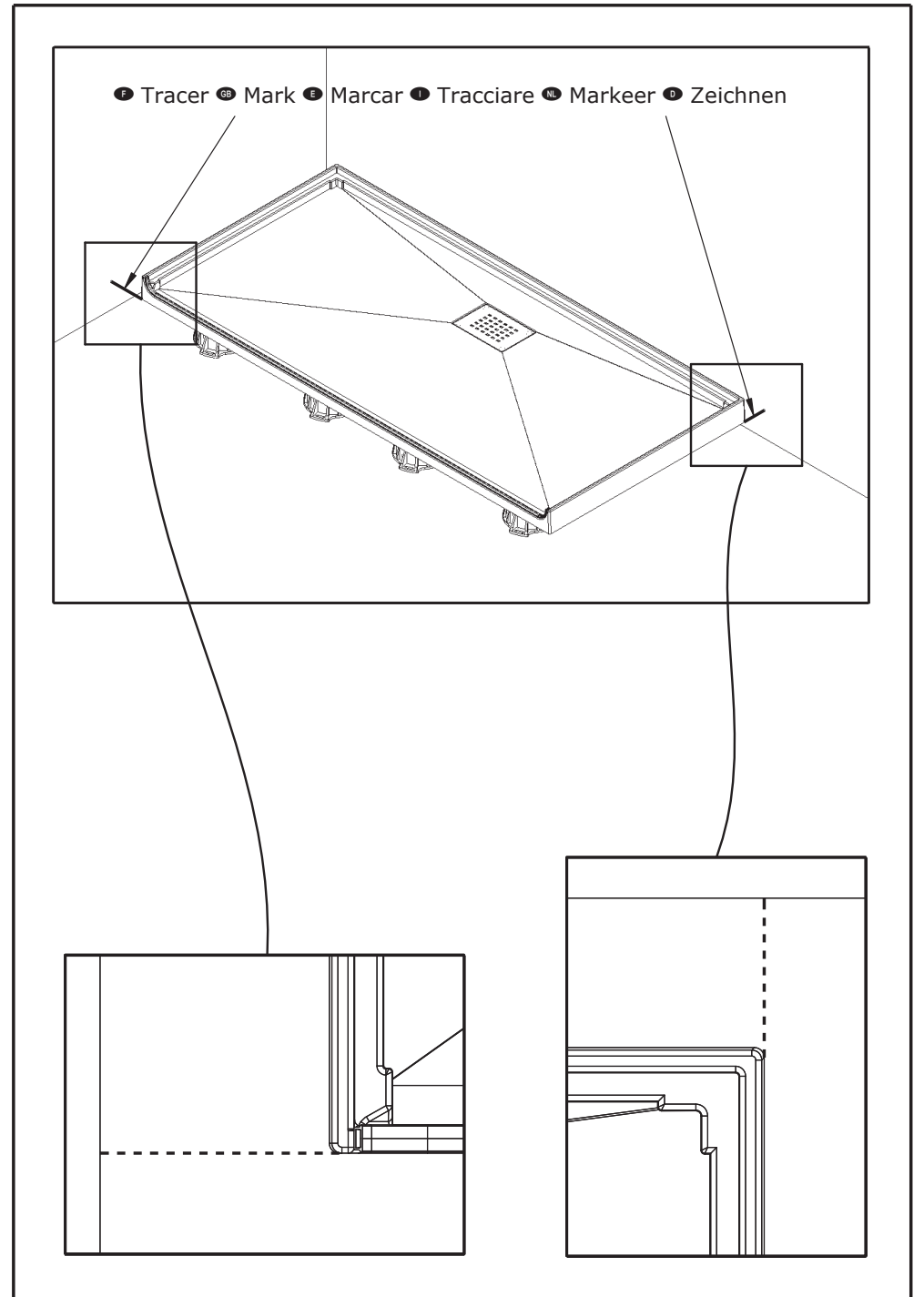

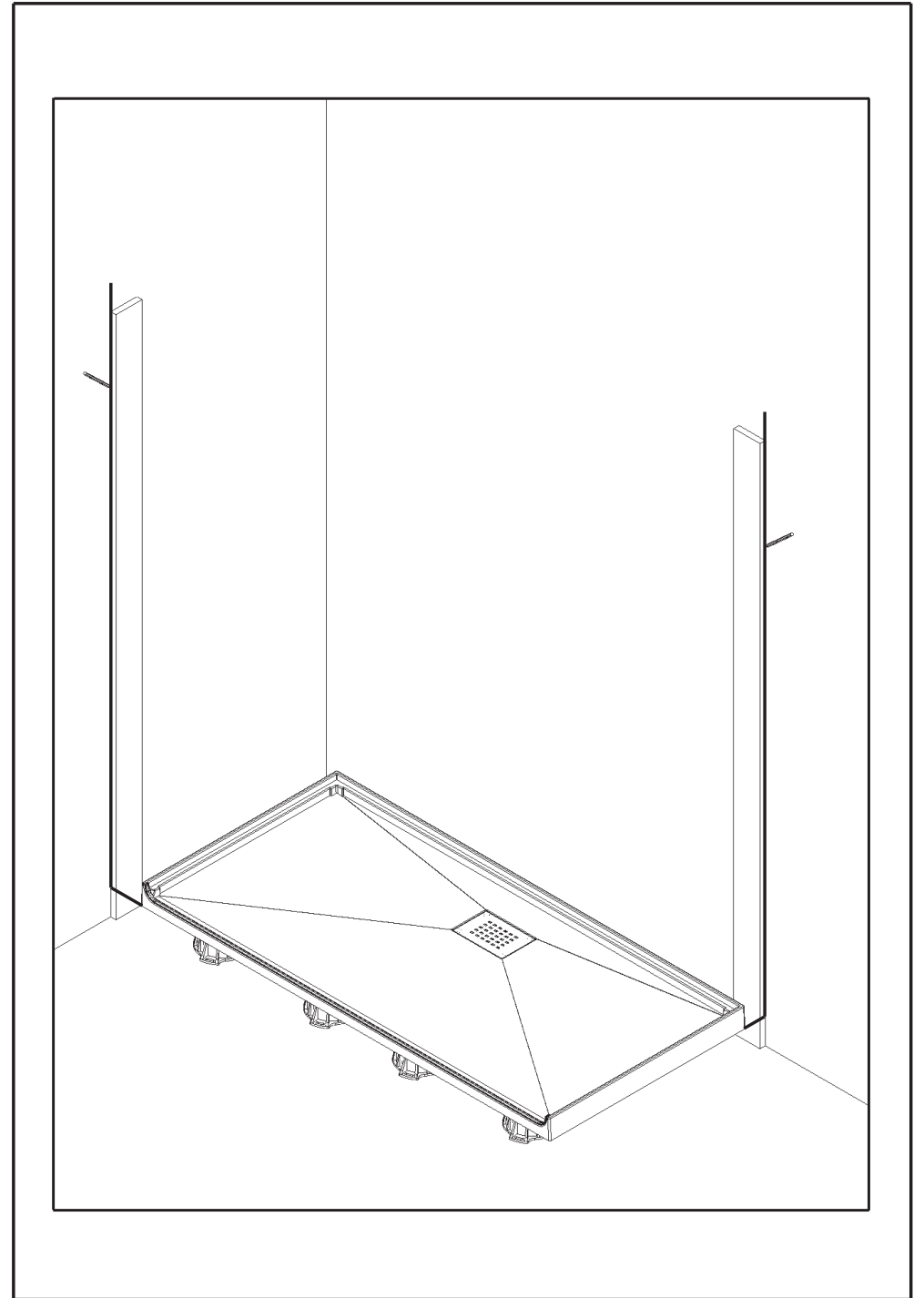
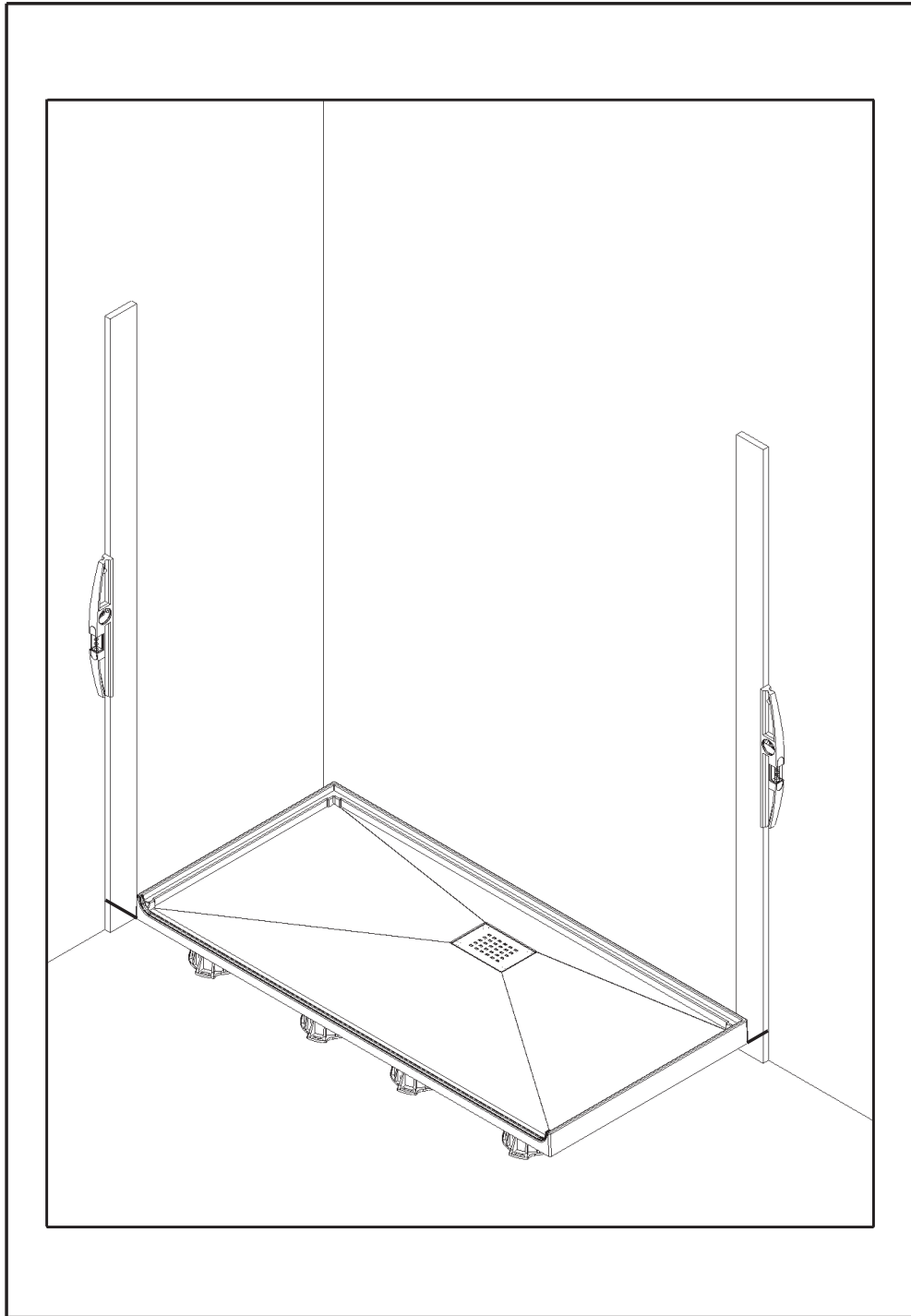

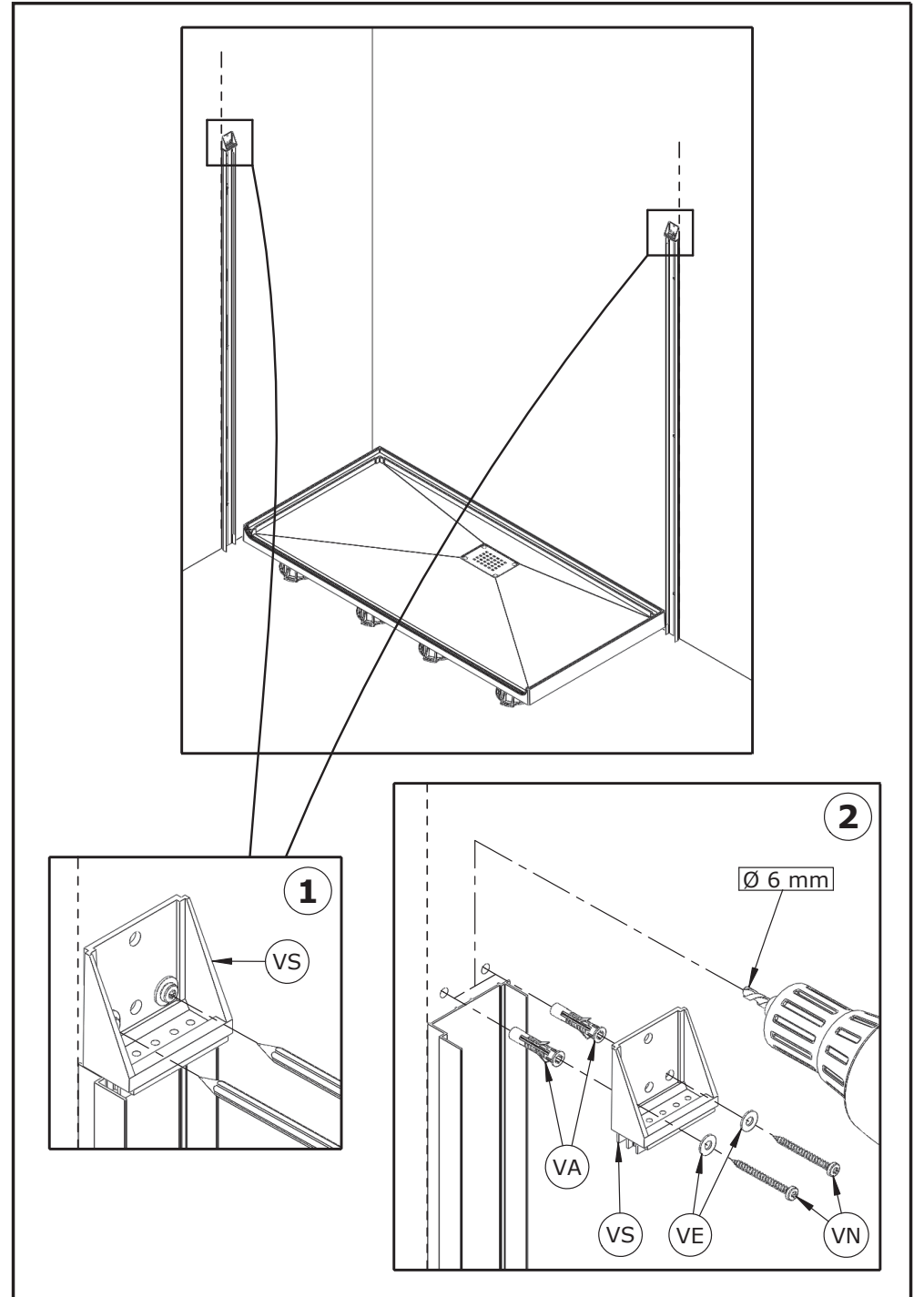
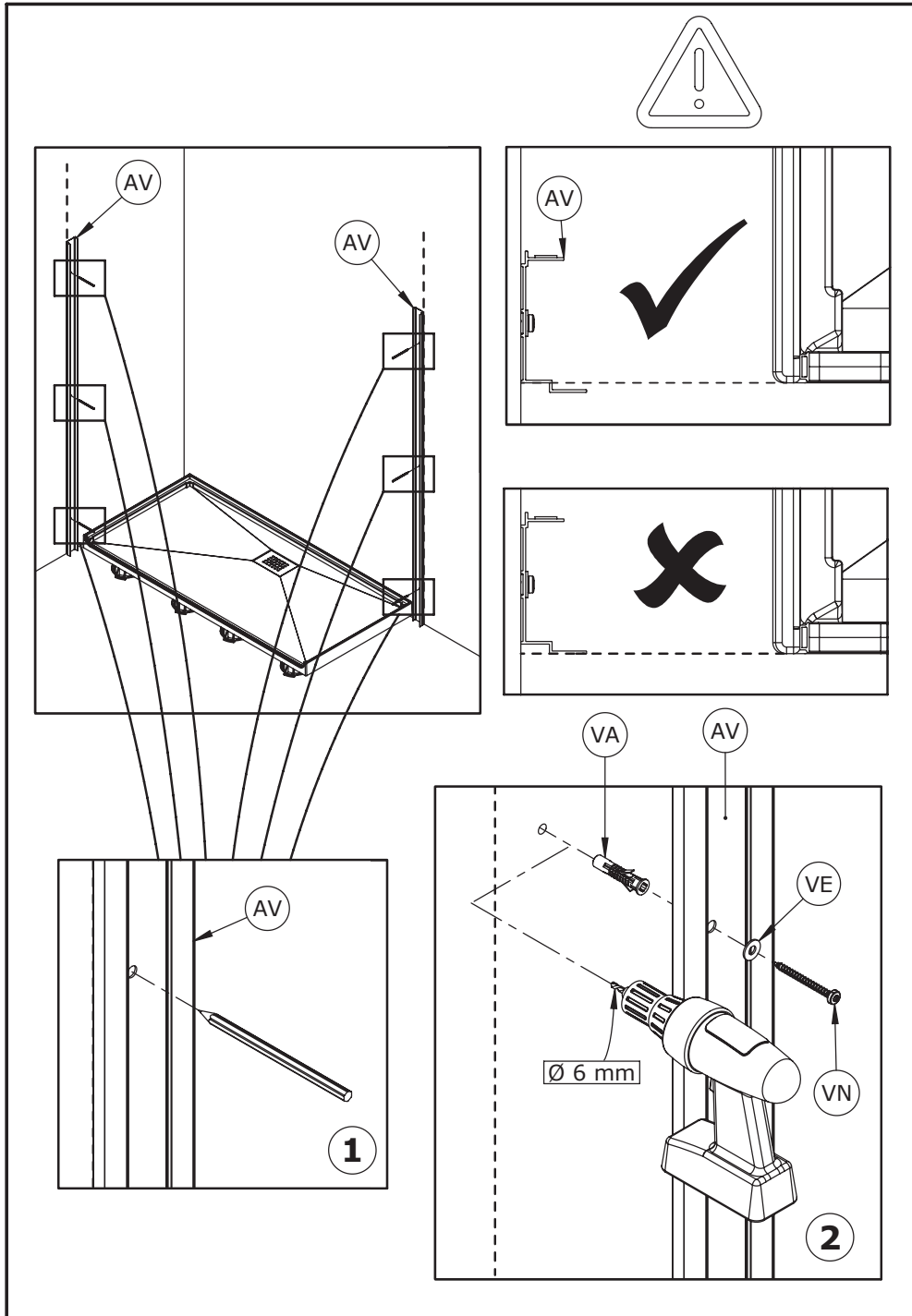

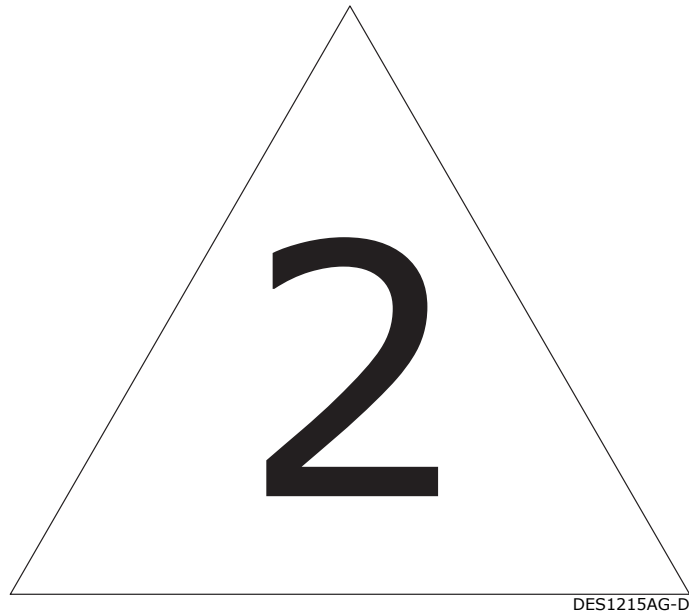

DES1215AG-D

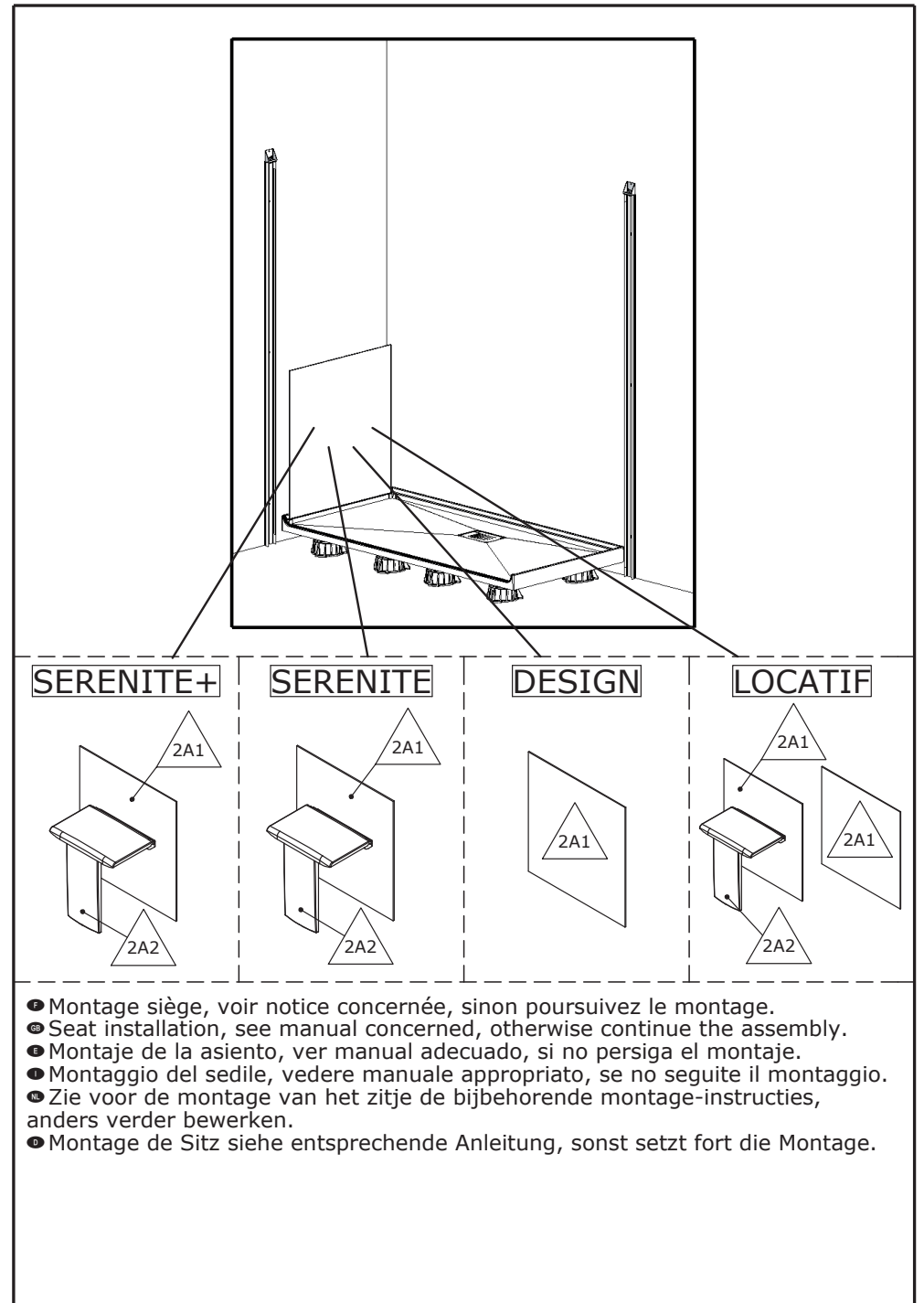

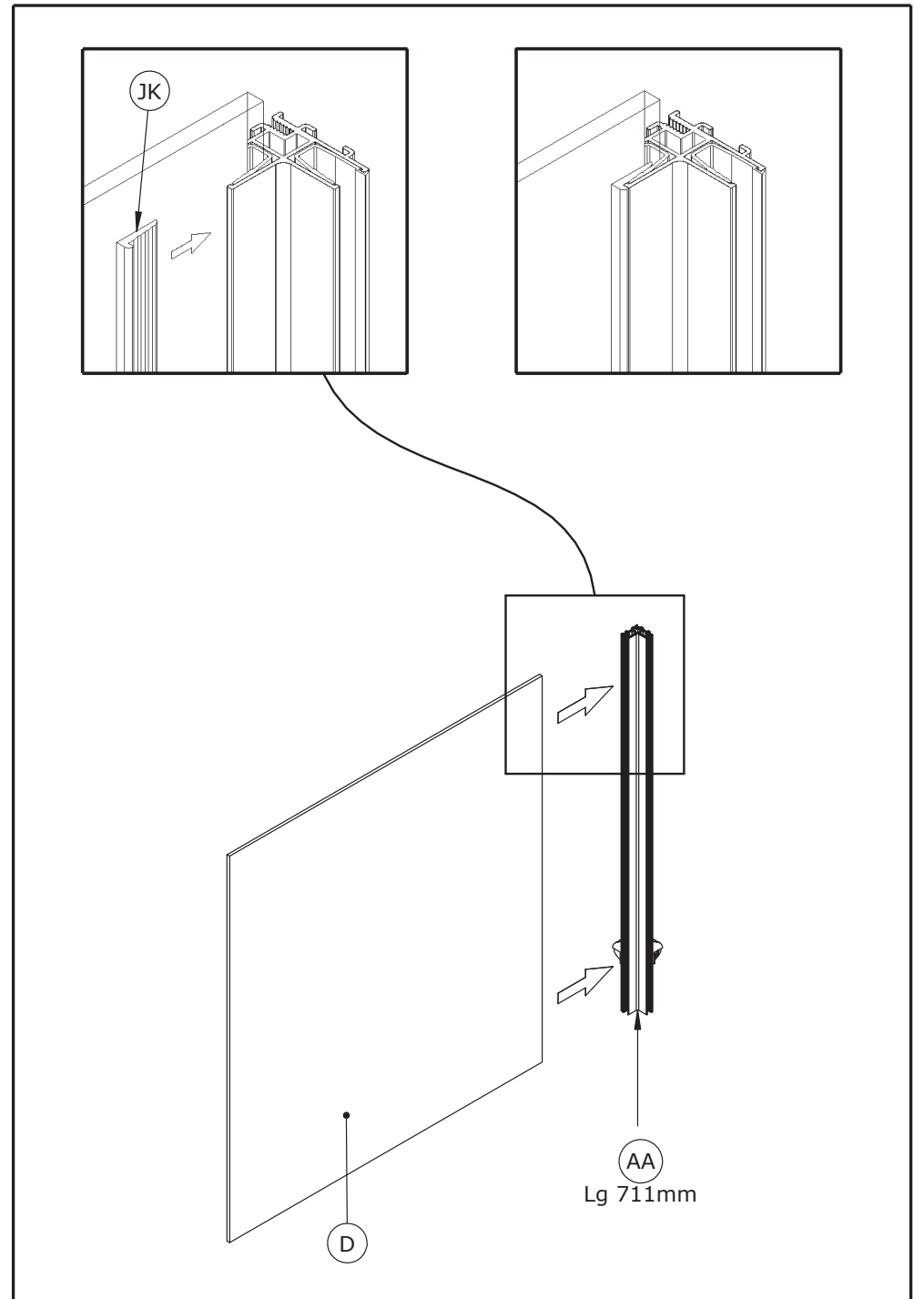
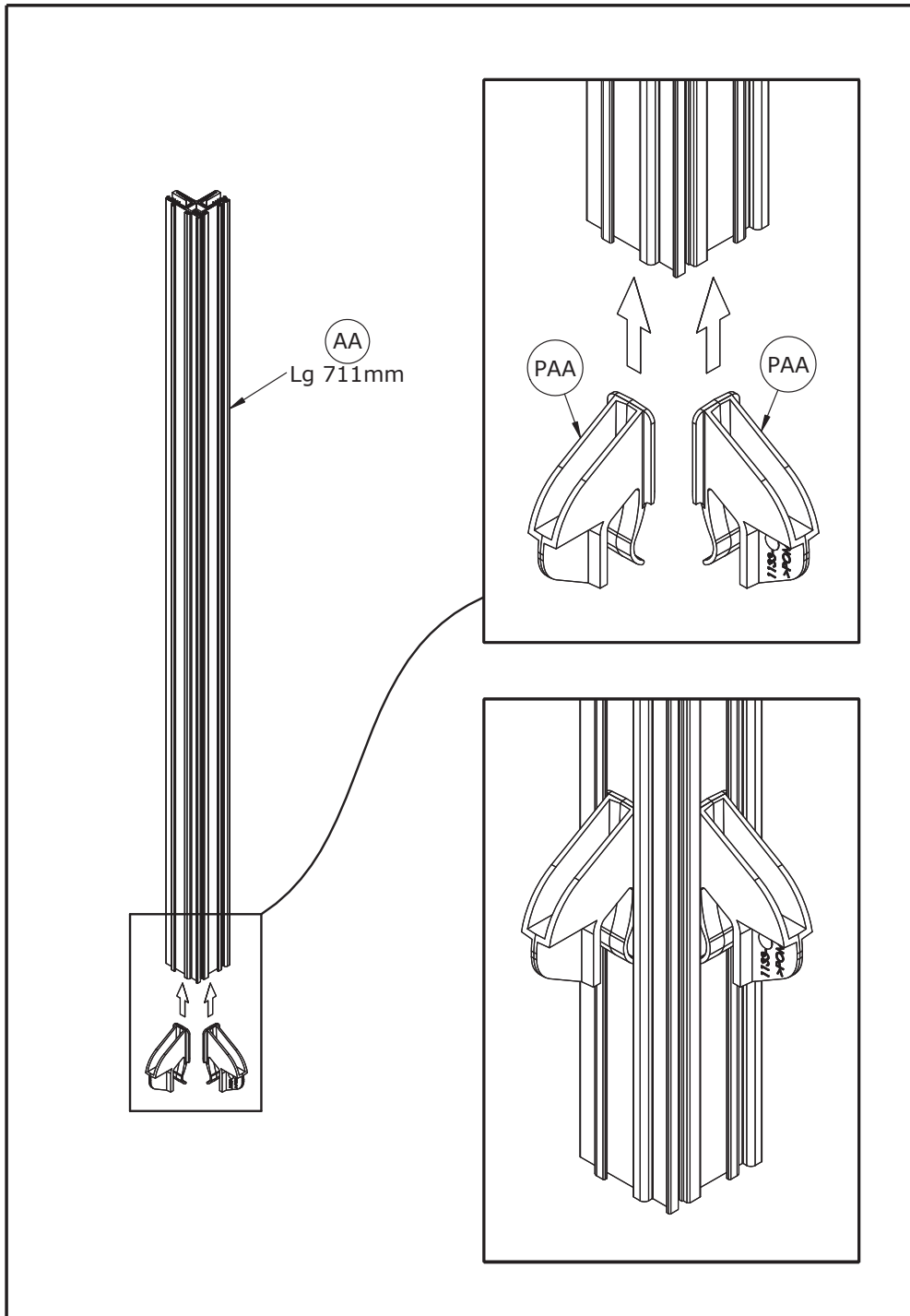

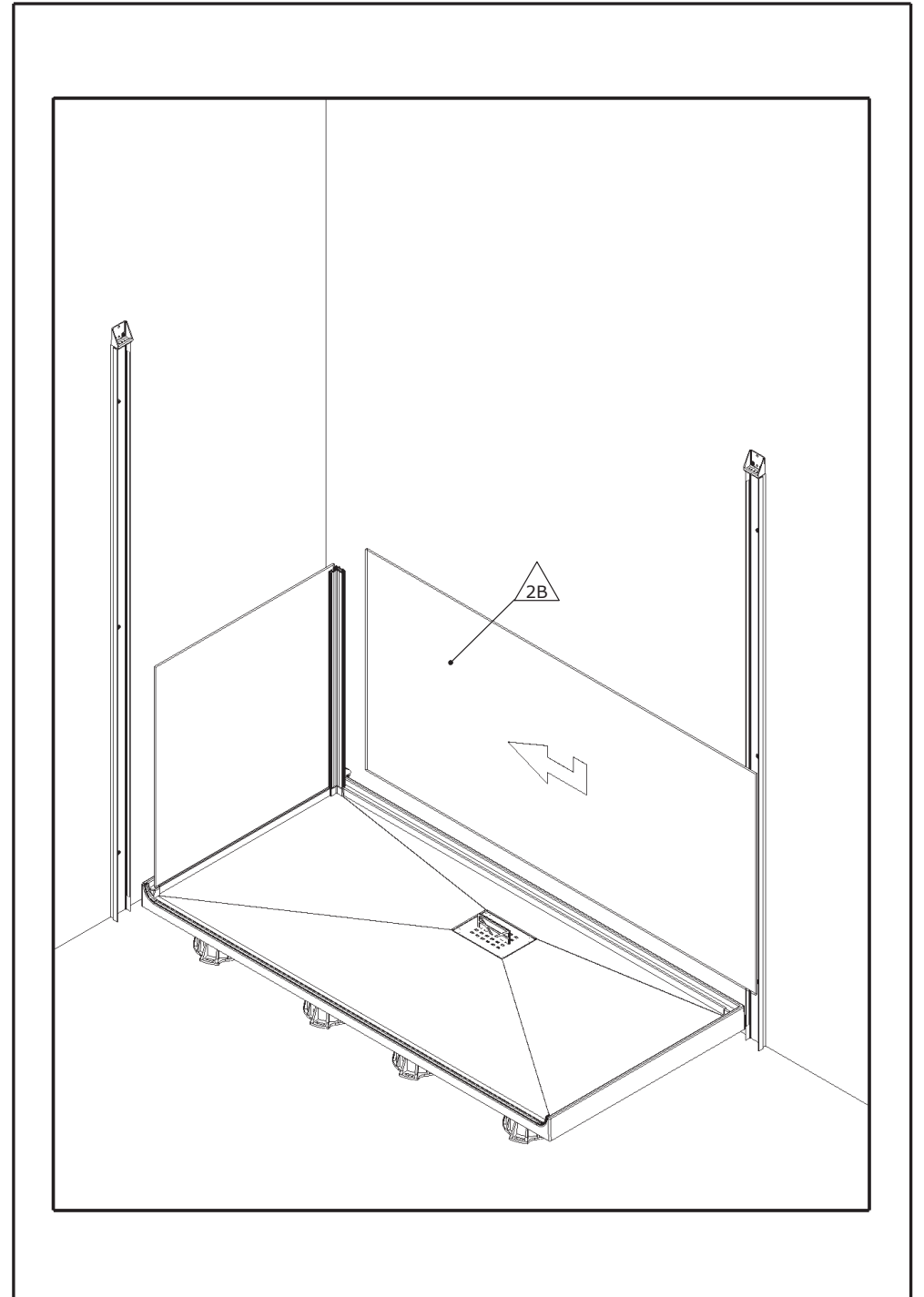
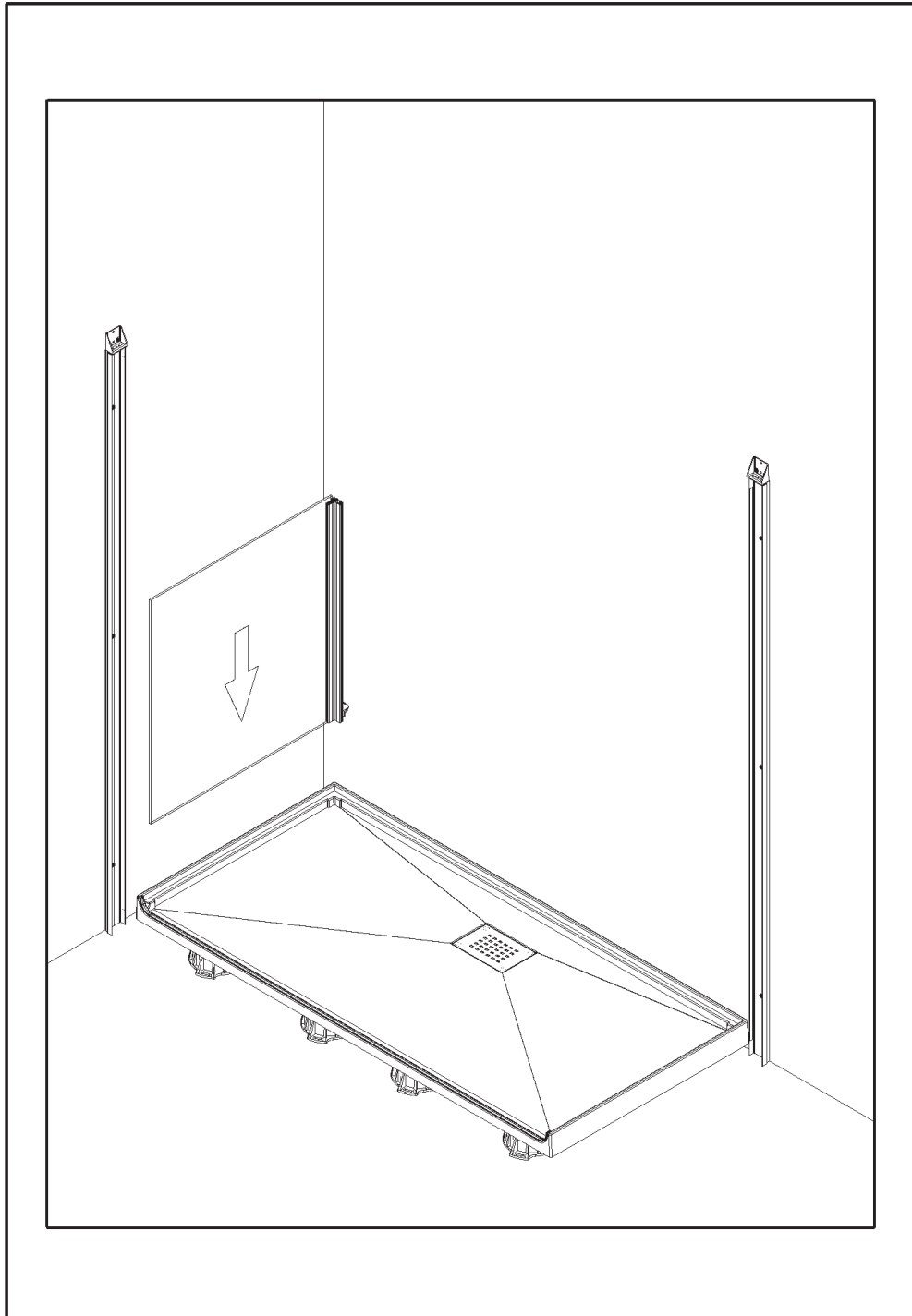

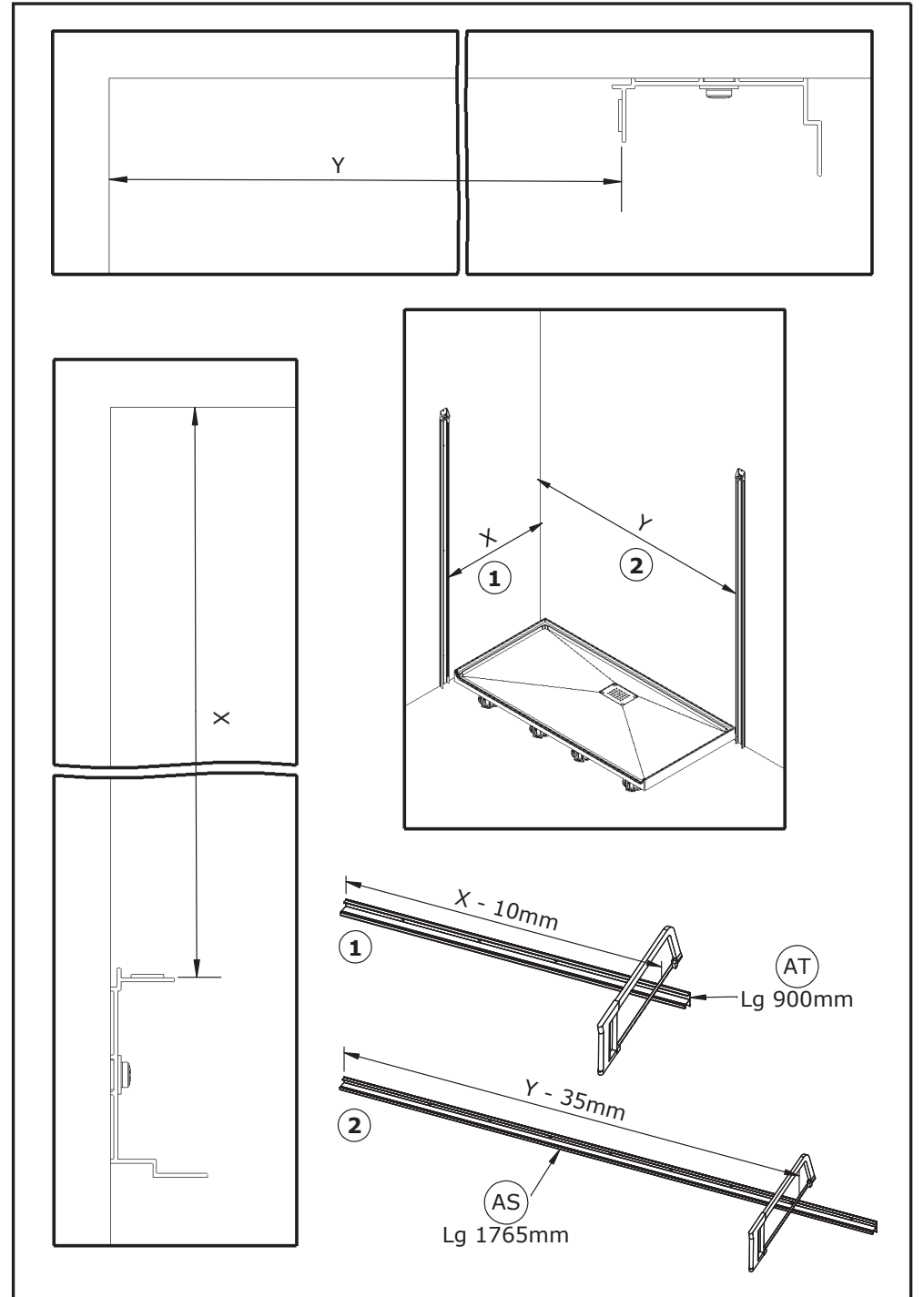
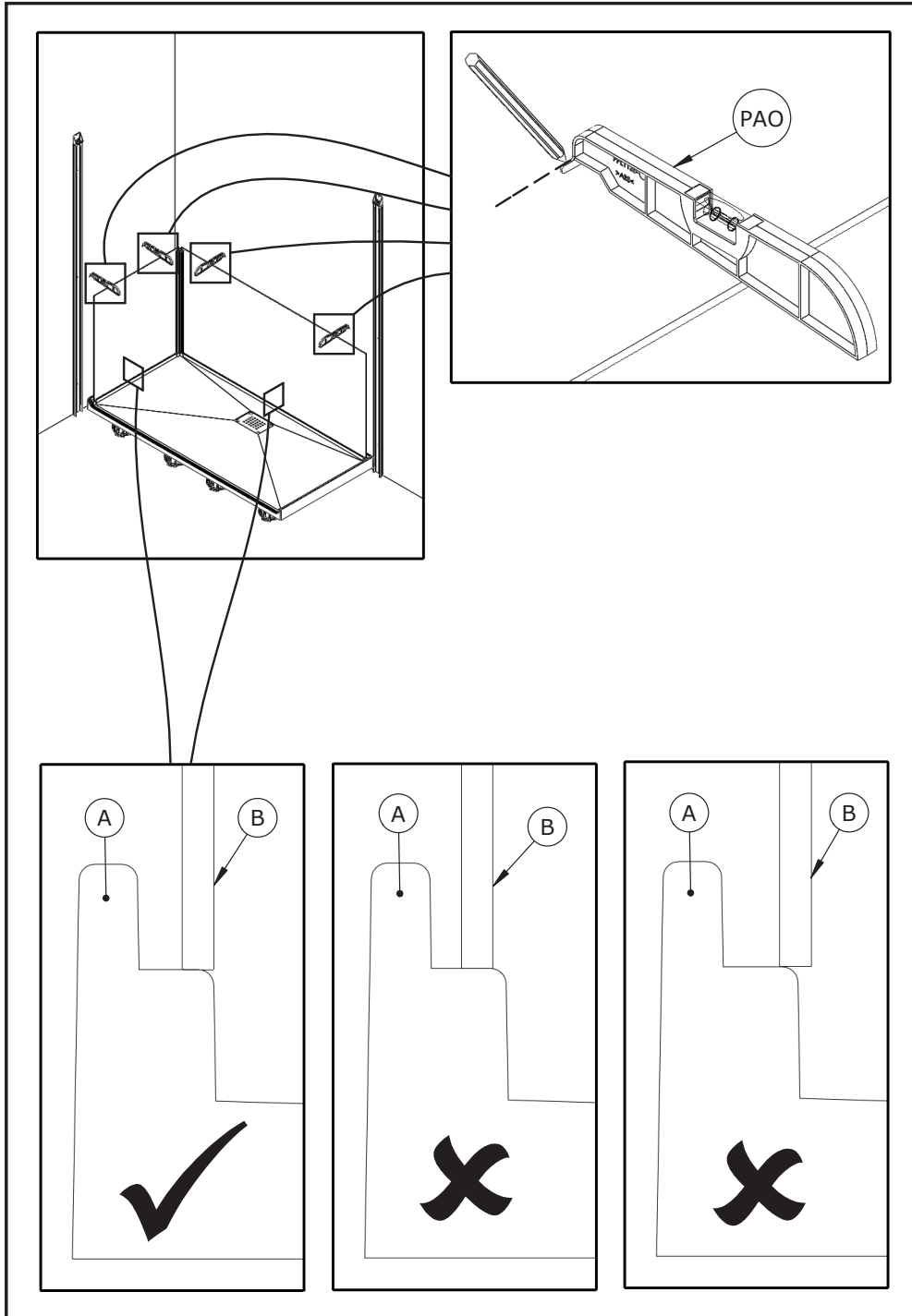

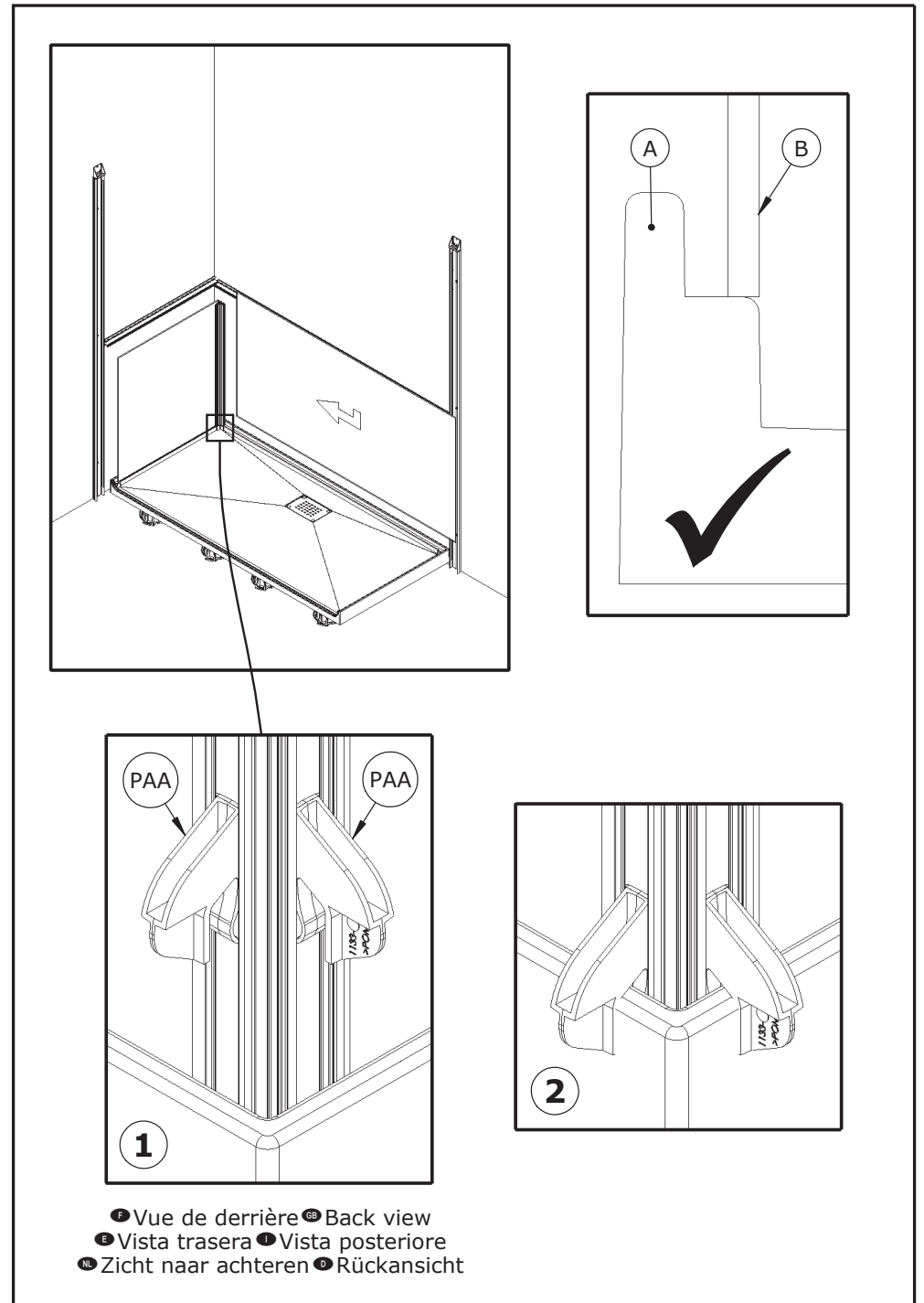
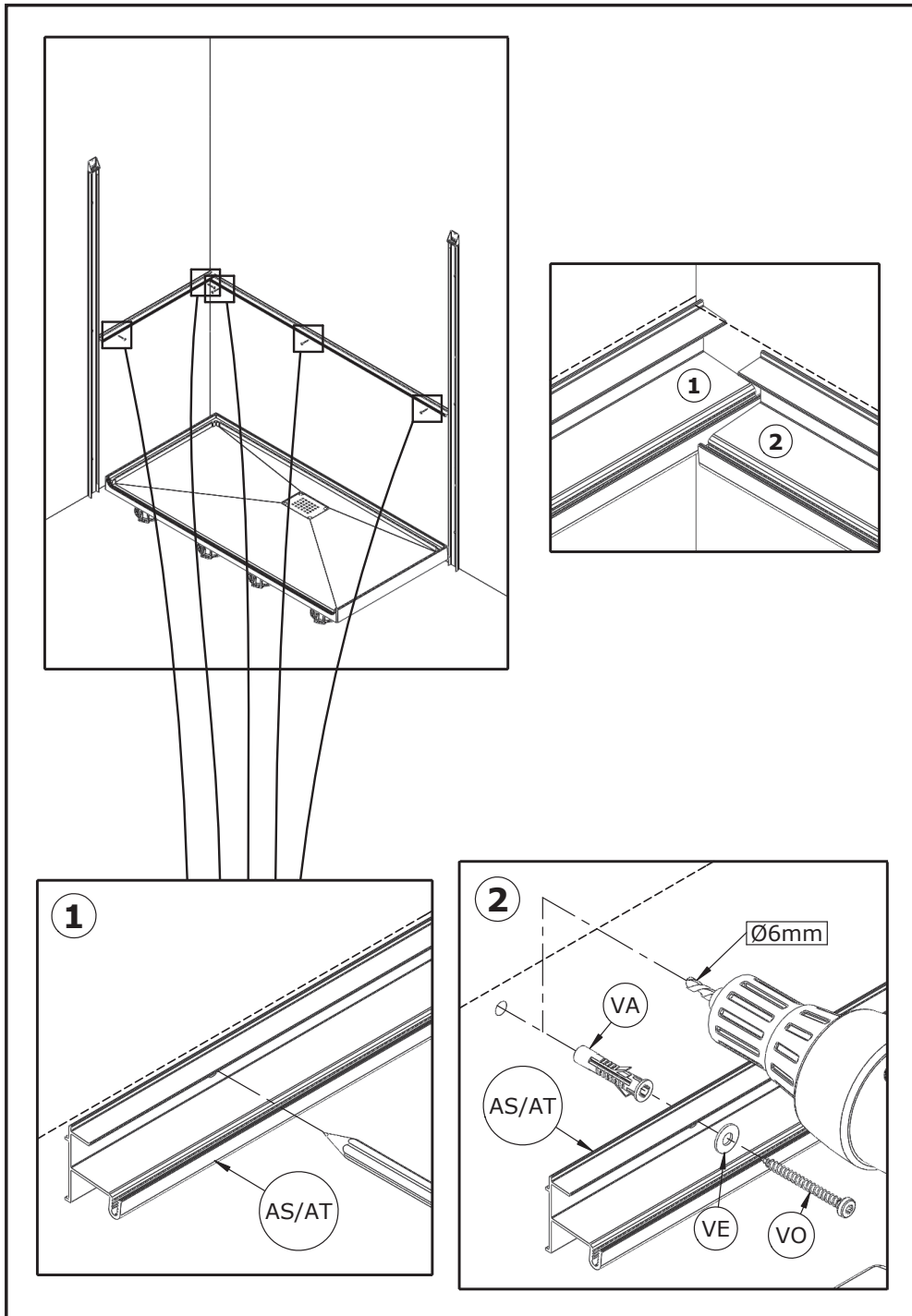

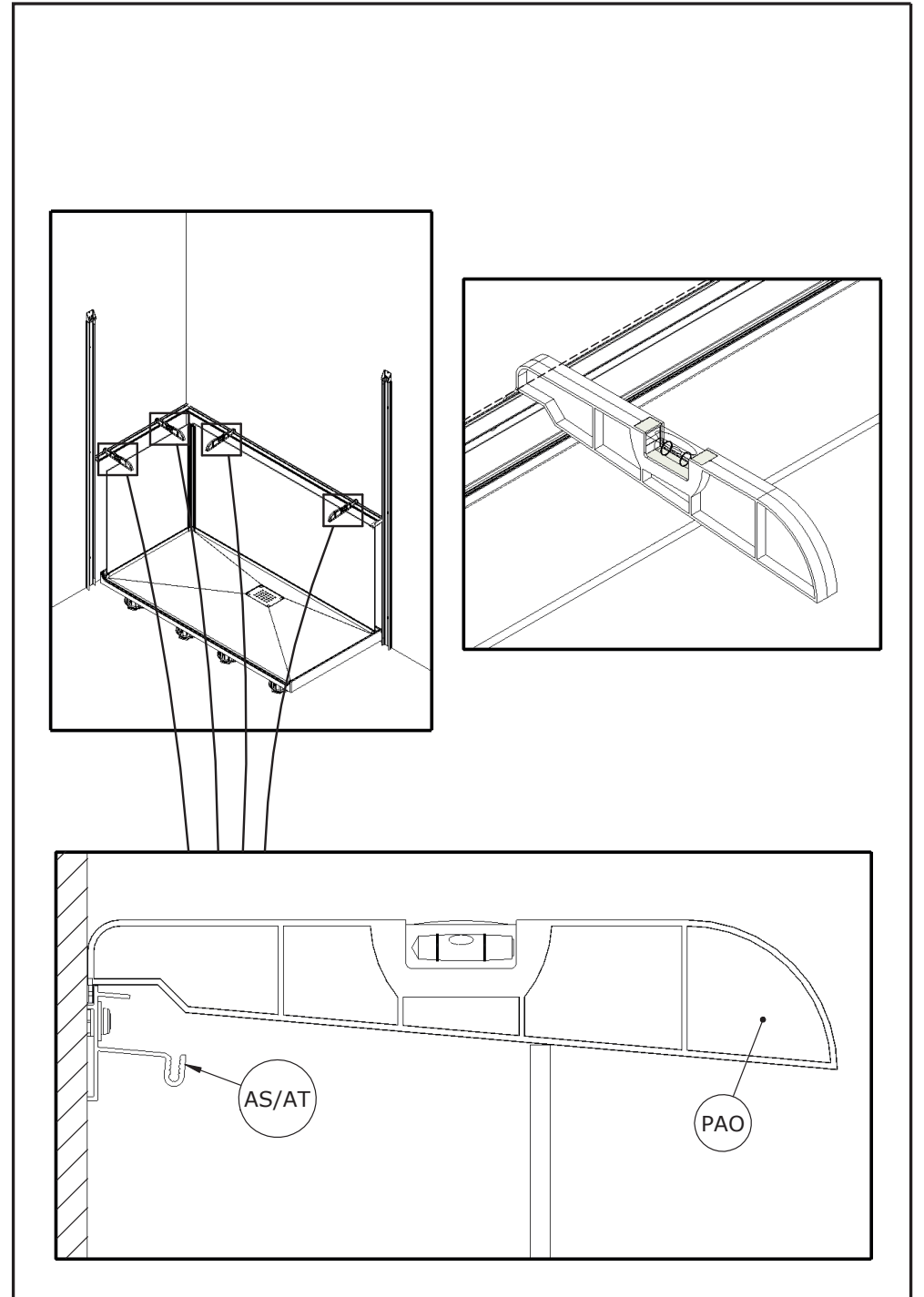
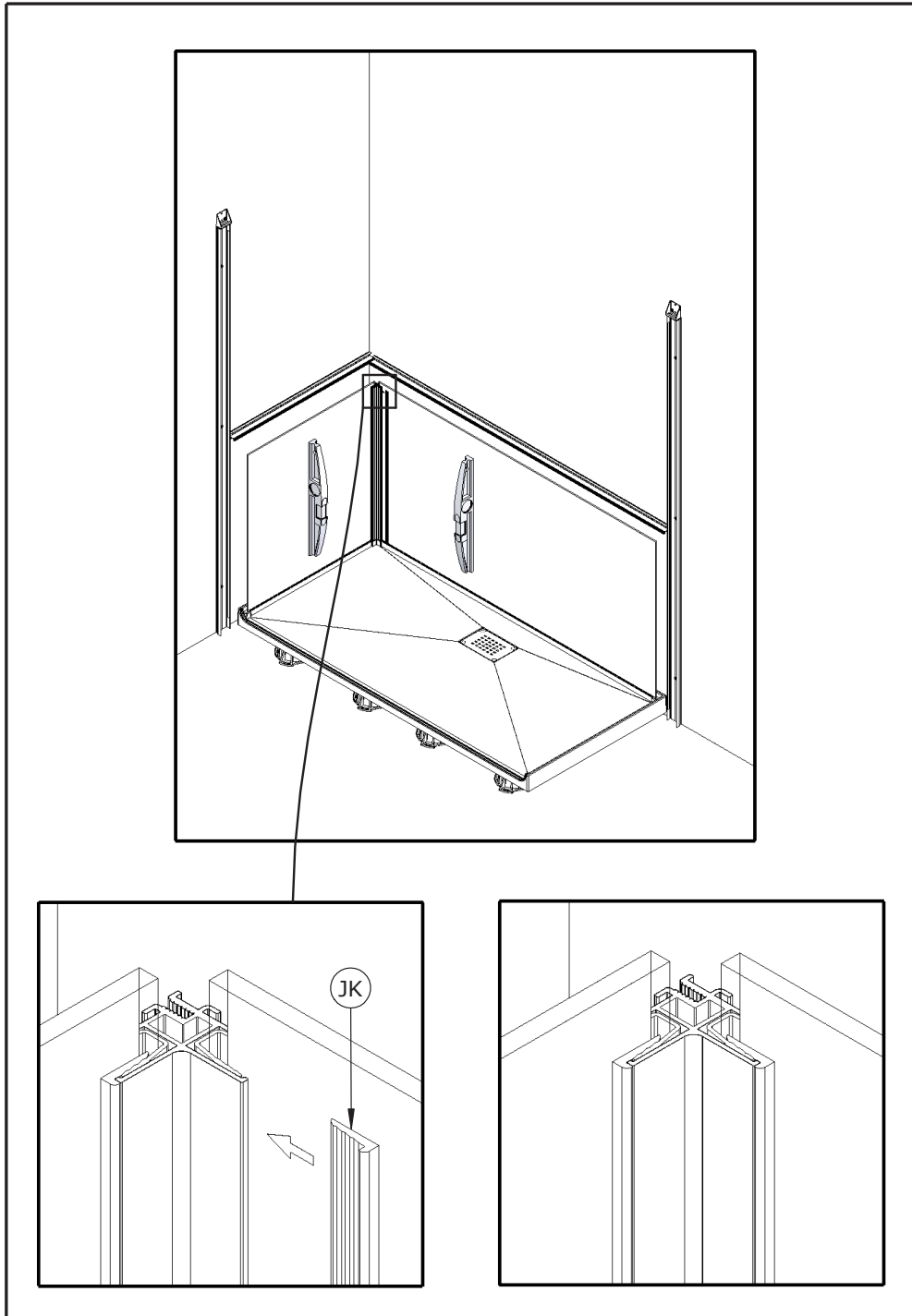

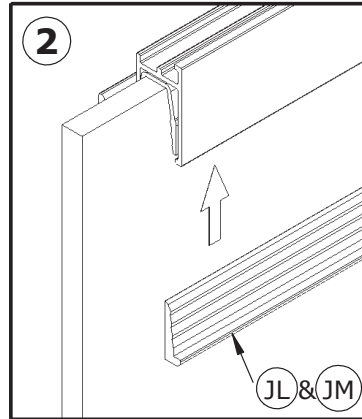
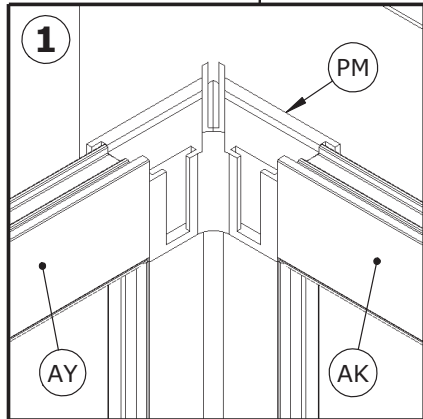
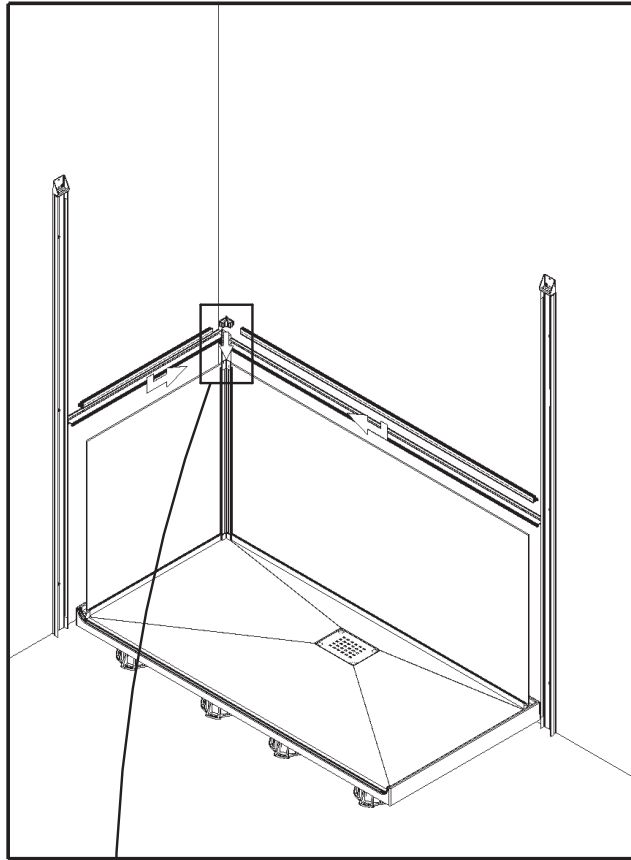

- F Attention au sens
- GB Attention to the direction
- E Atención a la dirección
- I Attenzione alla direzione
- N Let op het gevoel
- D Richtung beachten

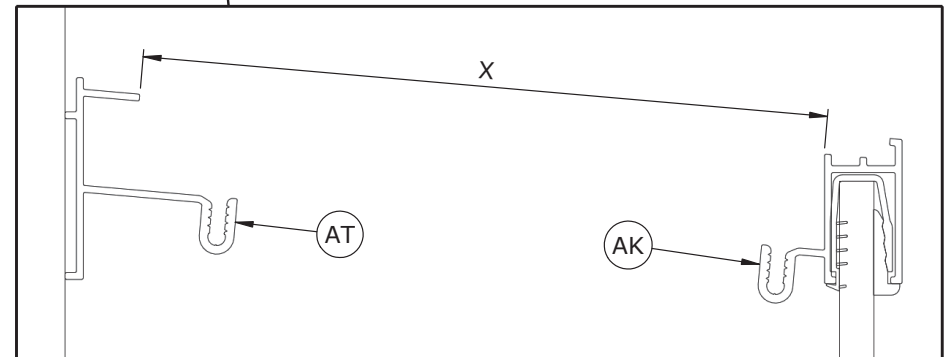
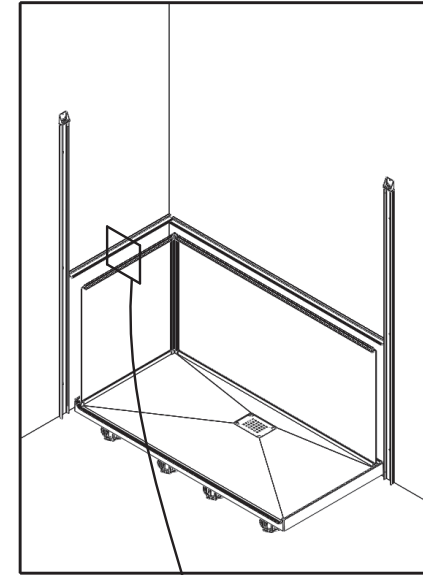
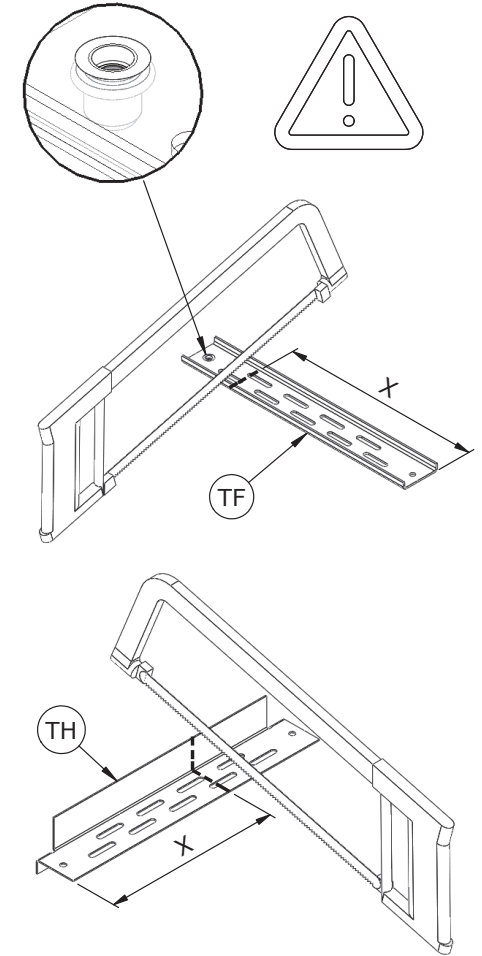

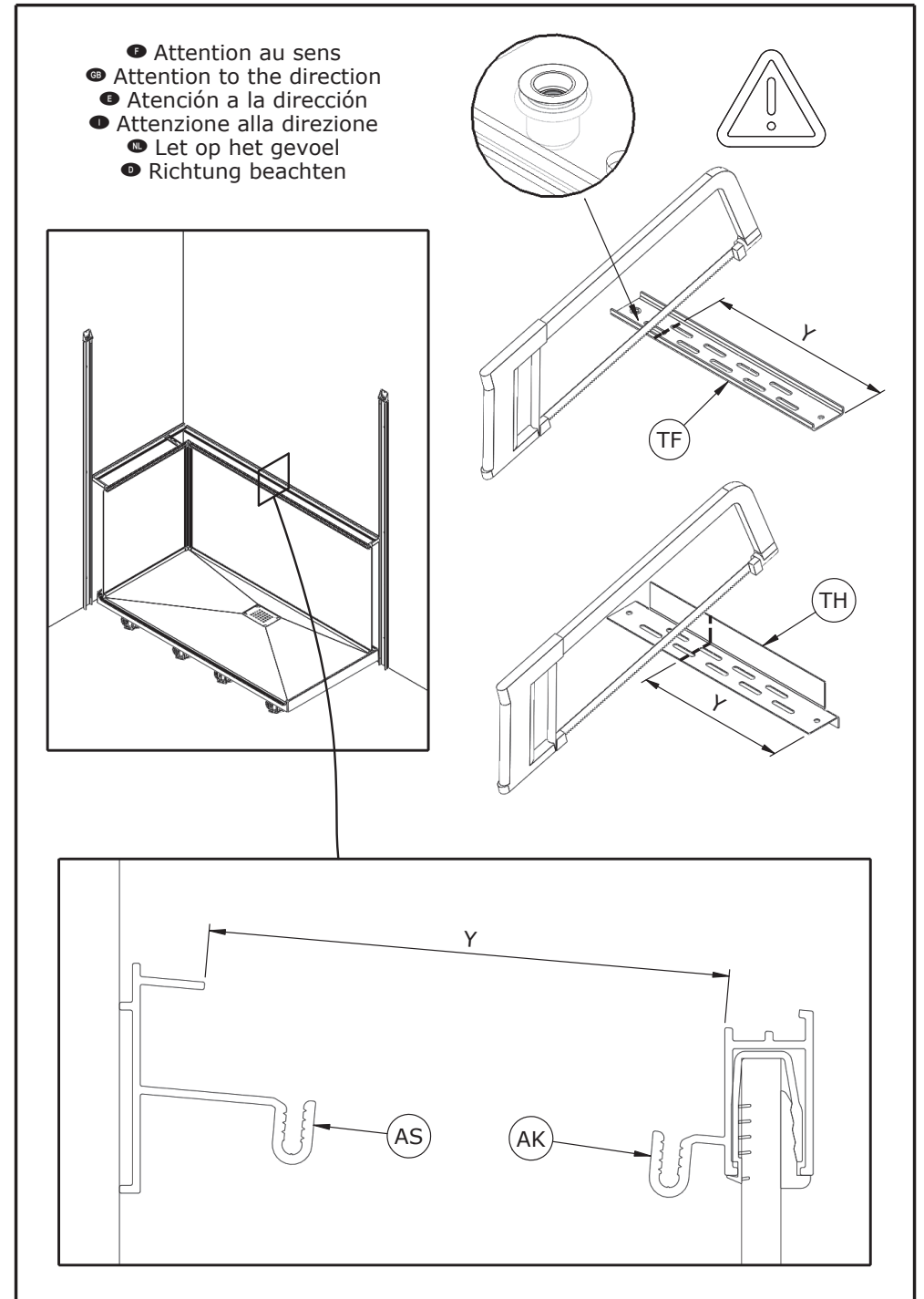
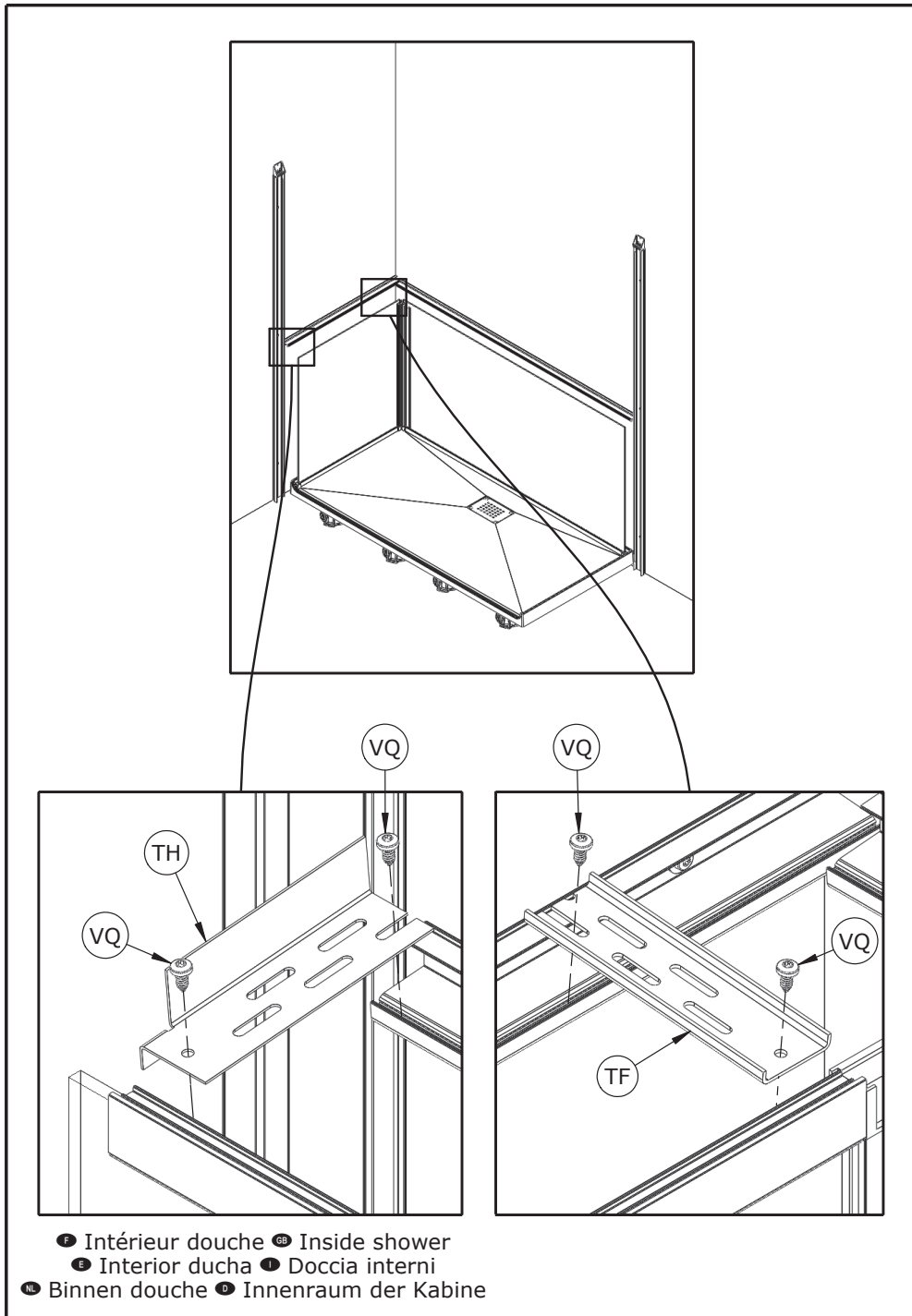

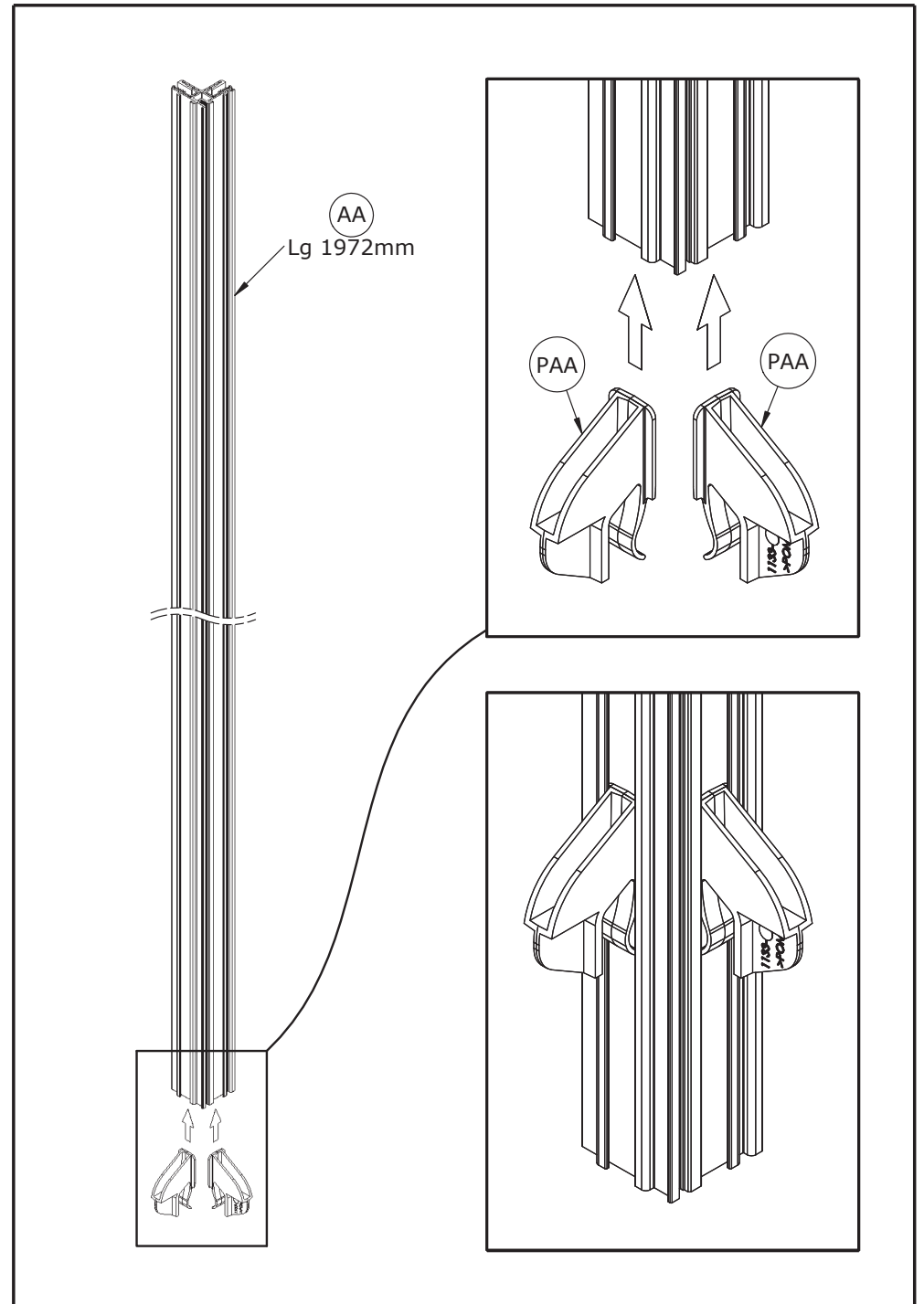
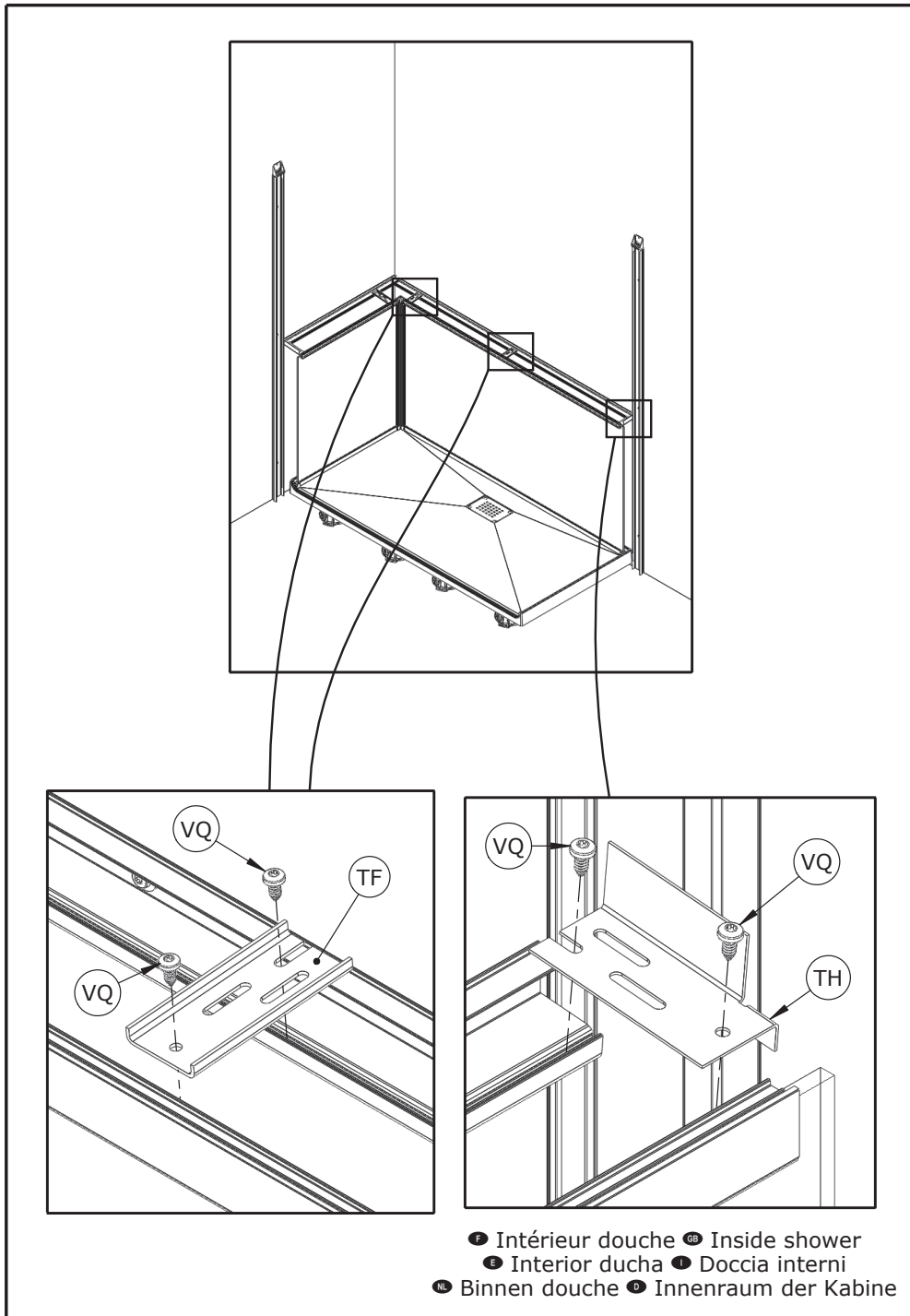

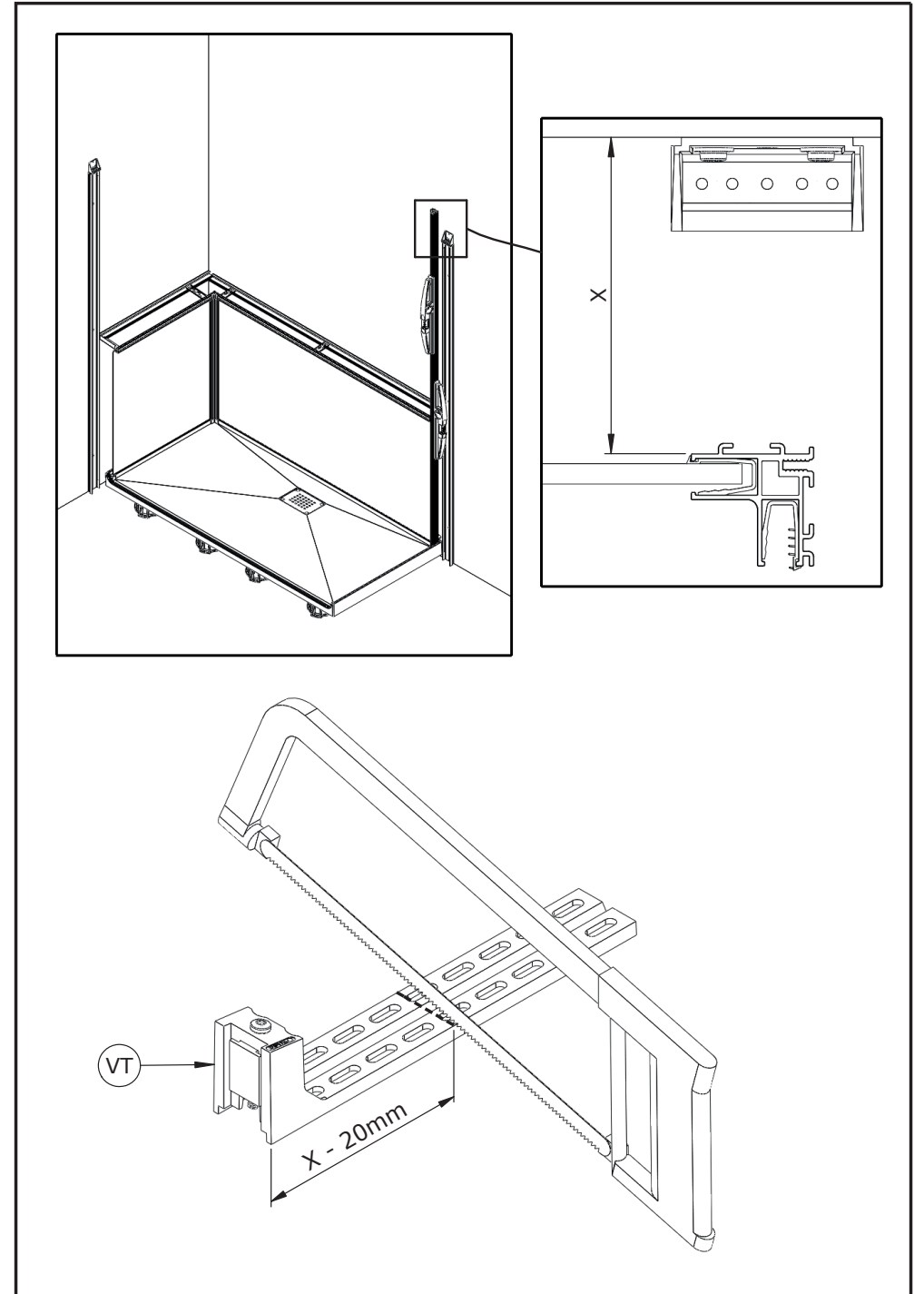
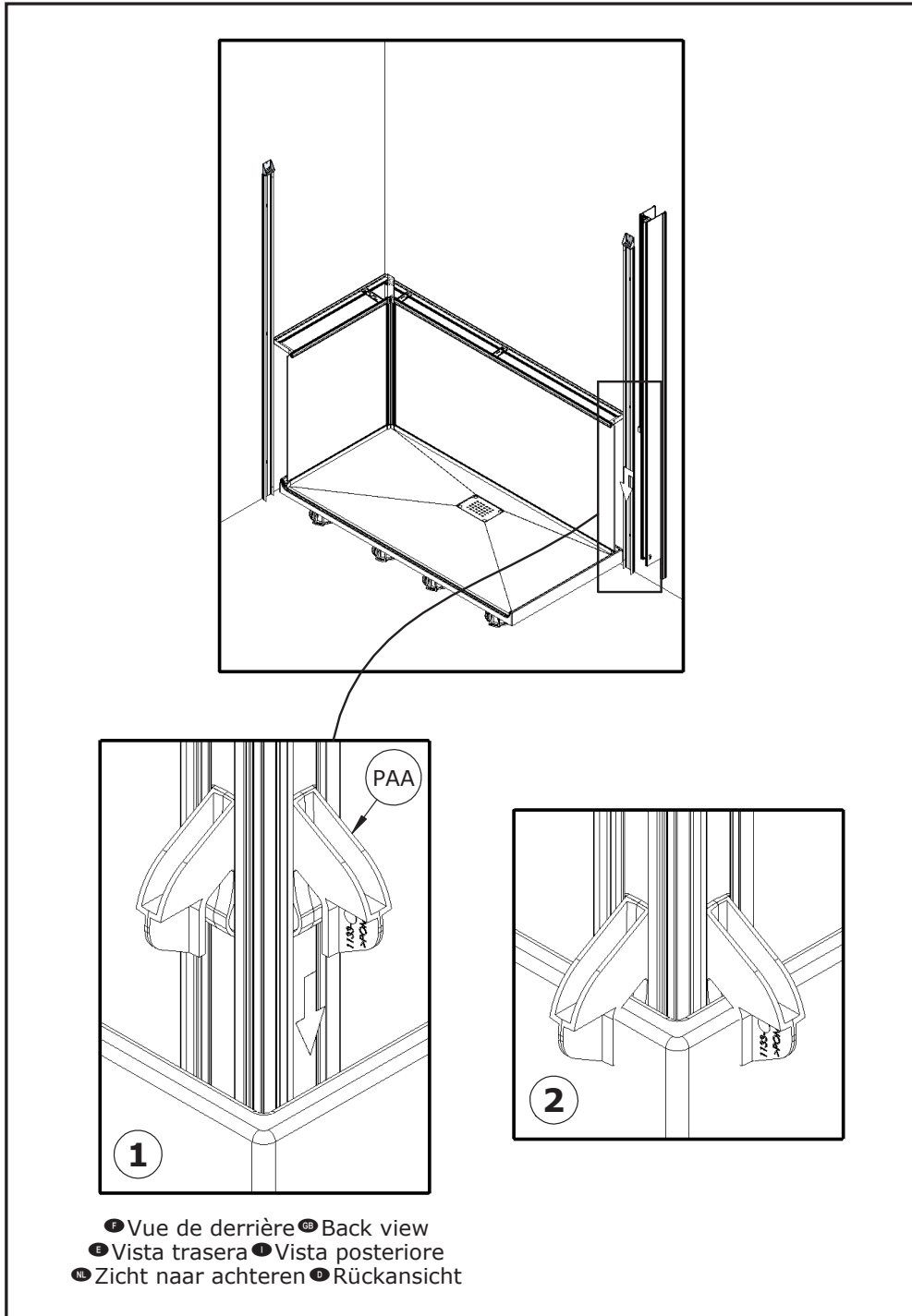

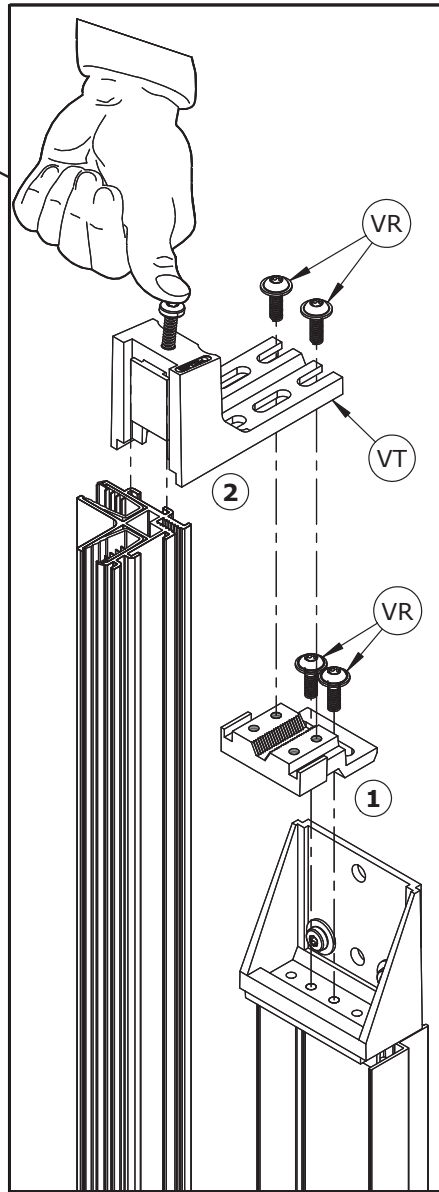
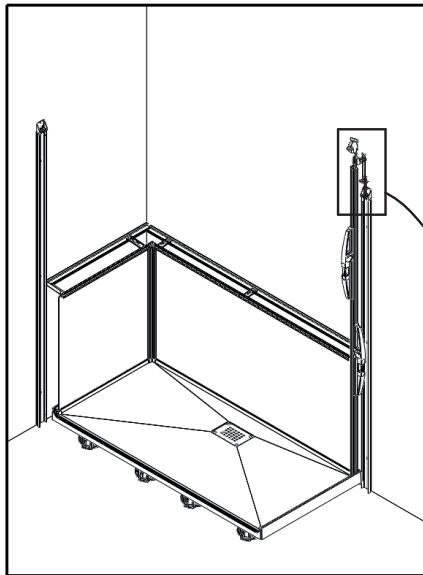

- ⦿ Serrer ⦿ Tighten
- ⦿ Apriete ⦿ Serrare
- ⦿ Festziehen ⦿ Aandraaien

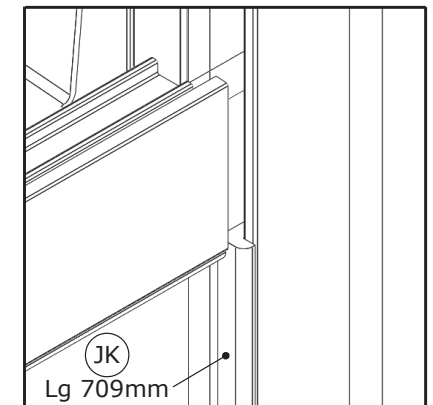
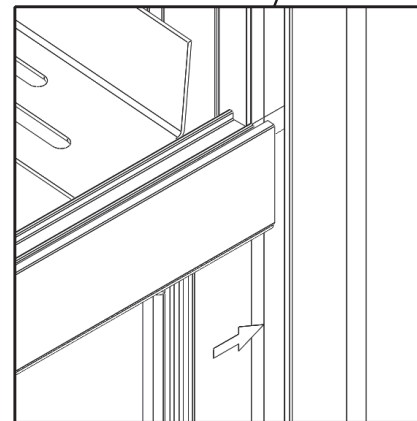
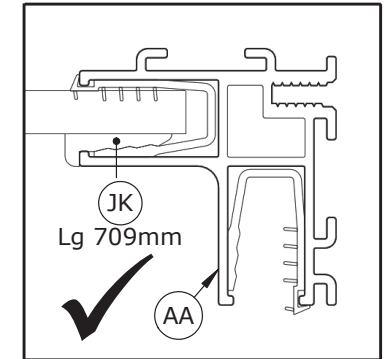
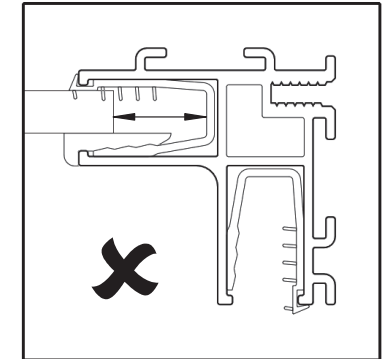
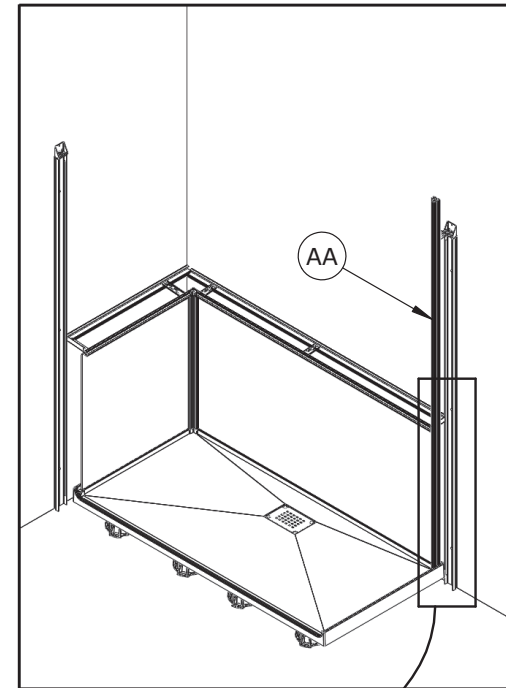
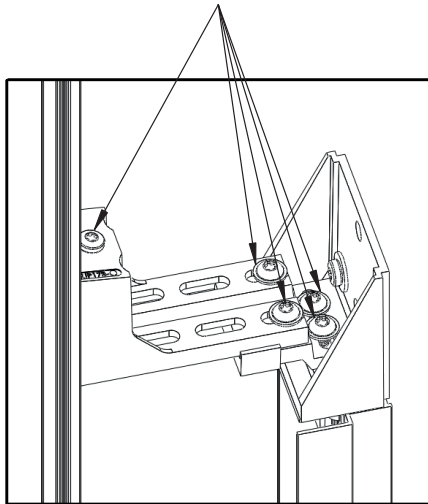



DES1198AG-E

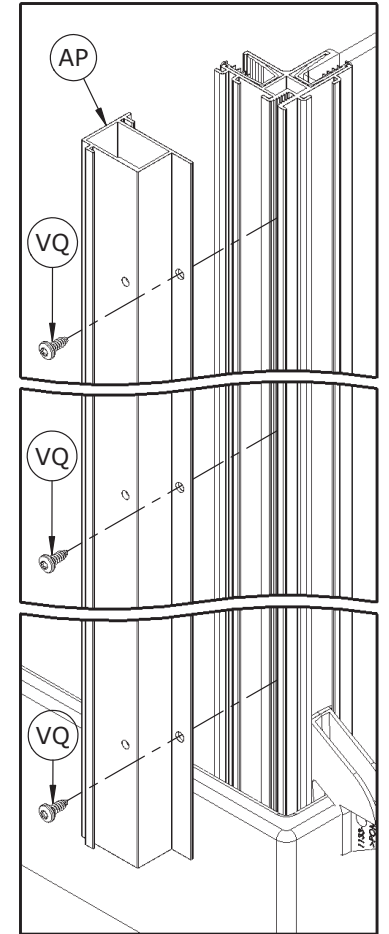
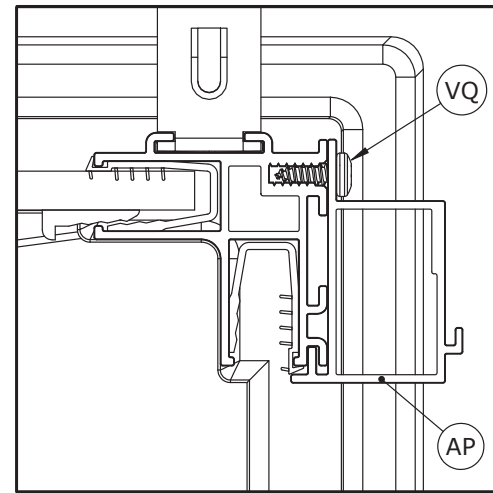
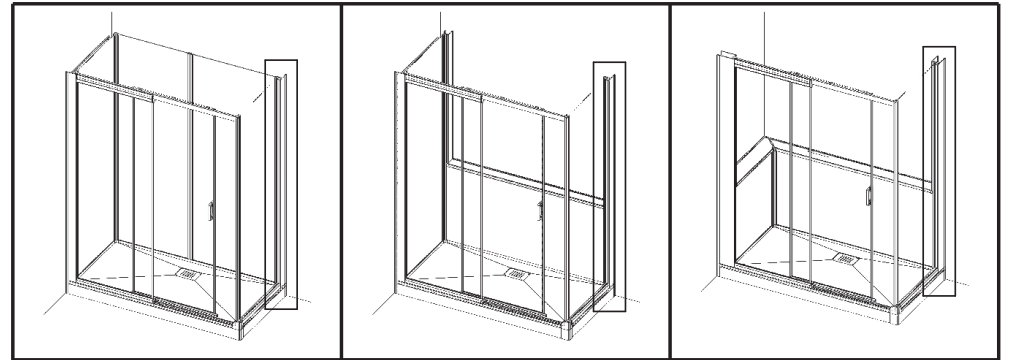

F Vue de derrière GB Back view
 E Vista trasera I Vista posteriore
 NL Zicht naar achteren D Rückansicht

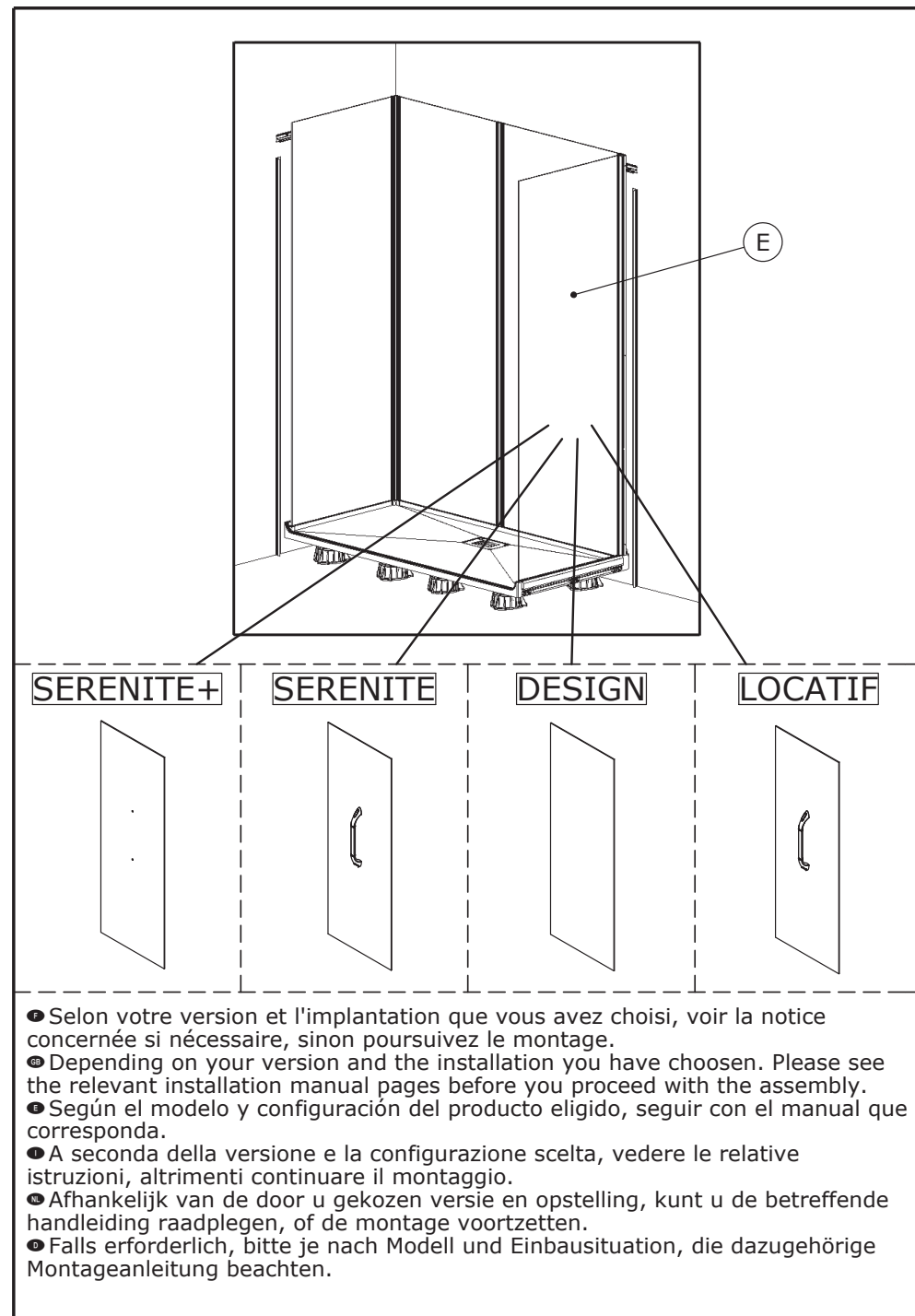
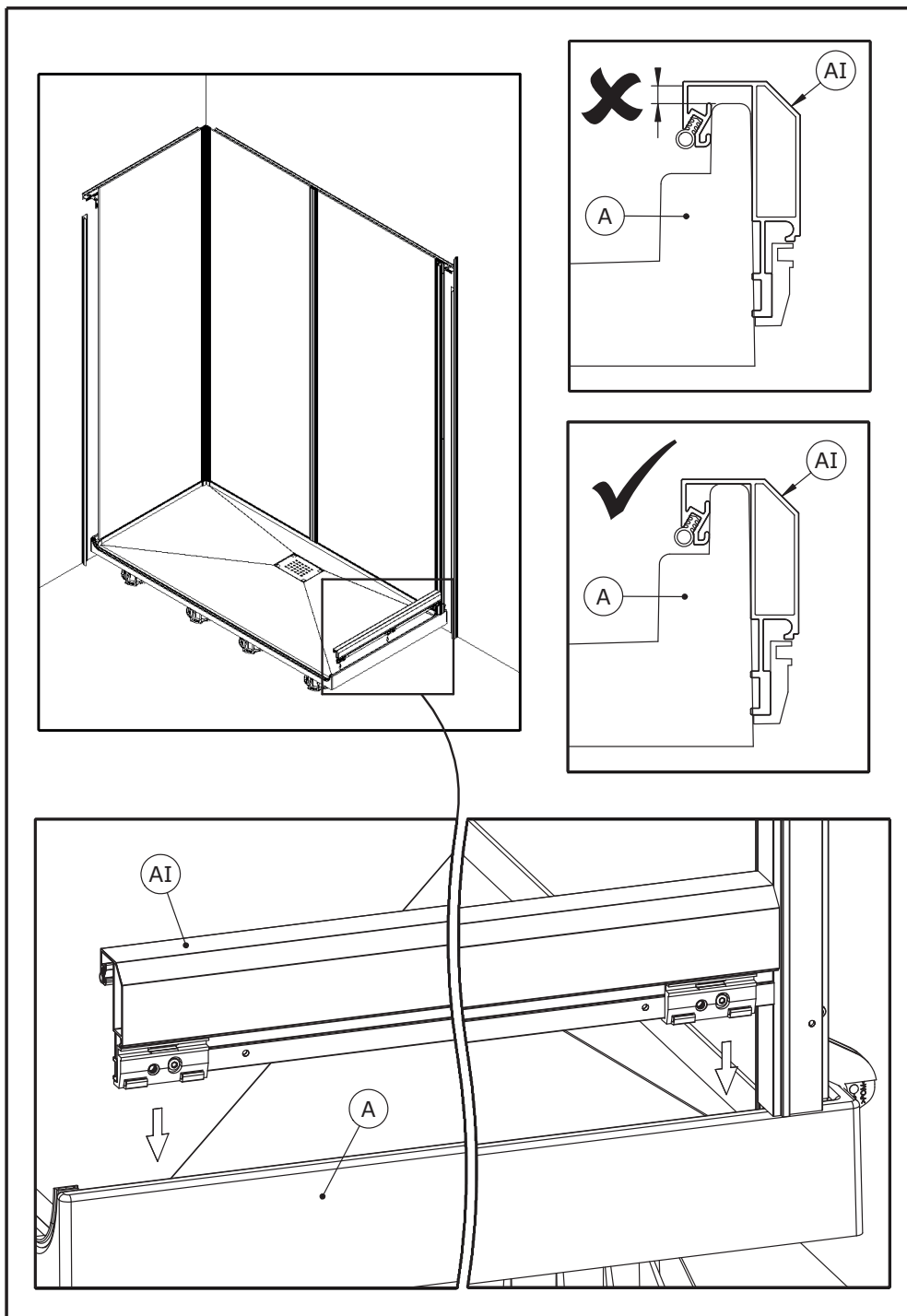

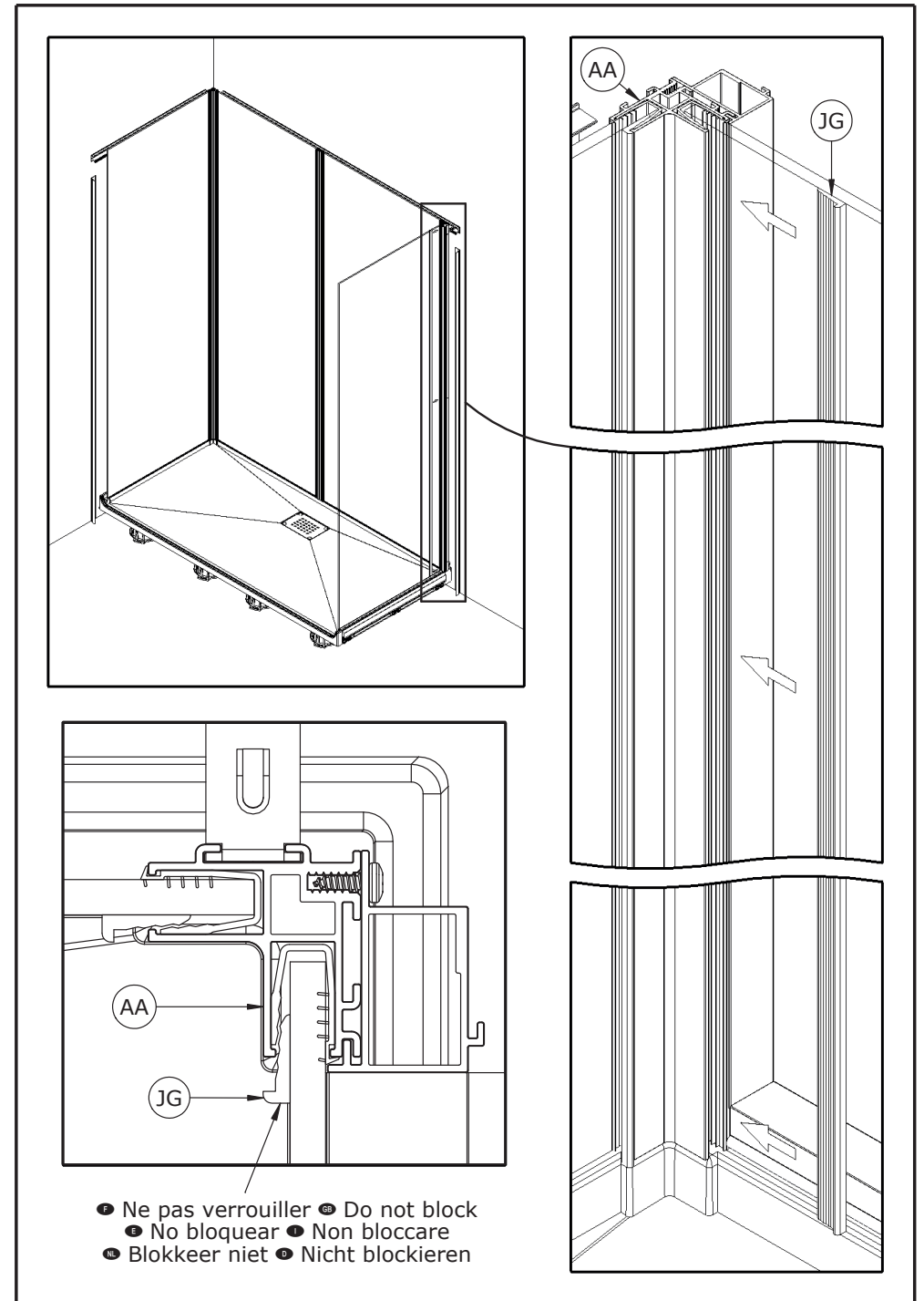
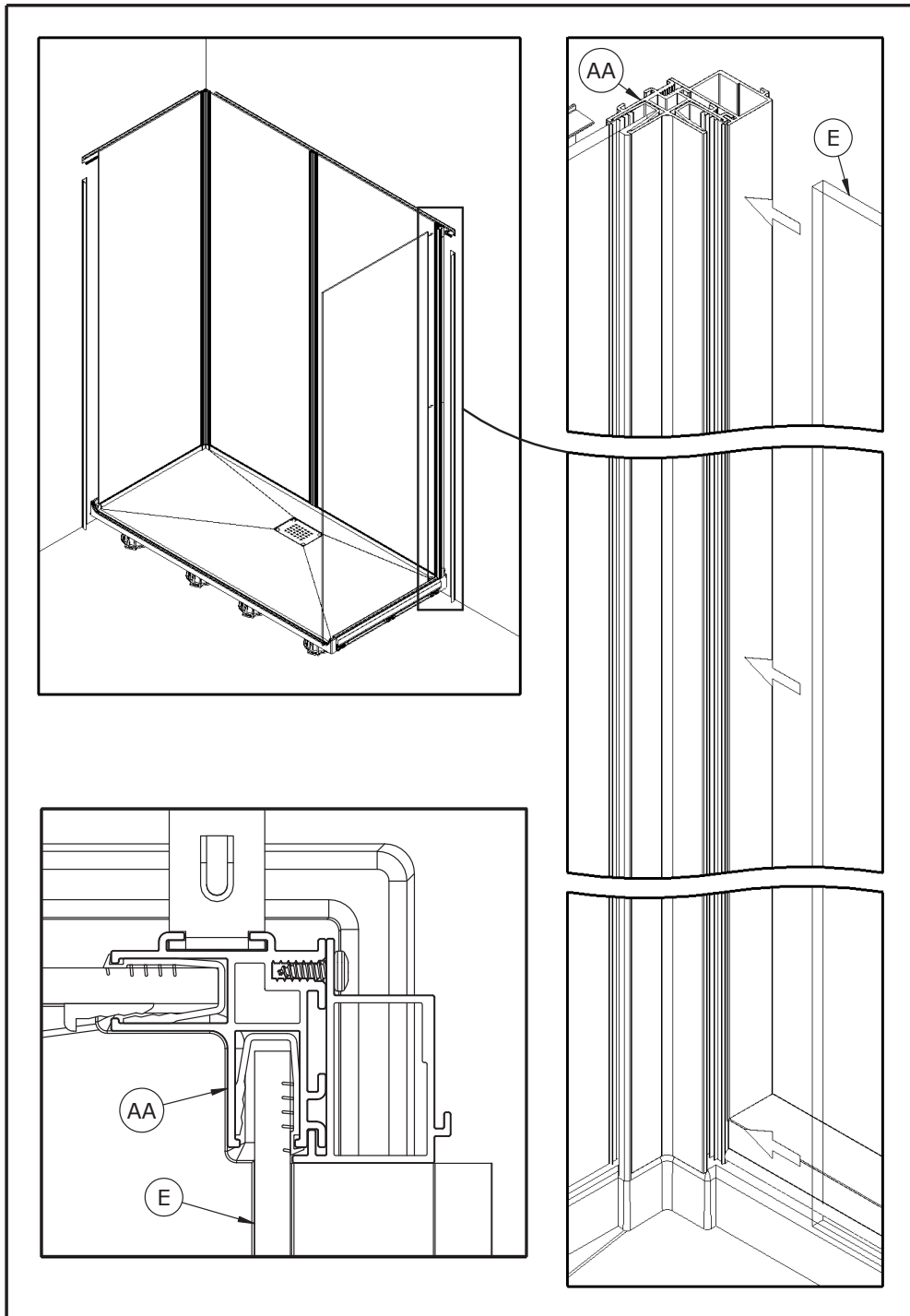

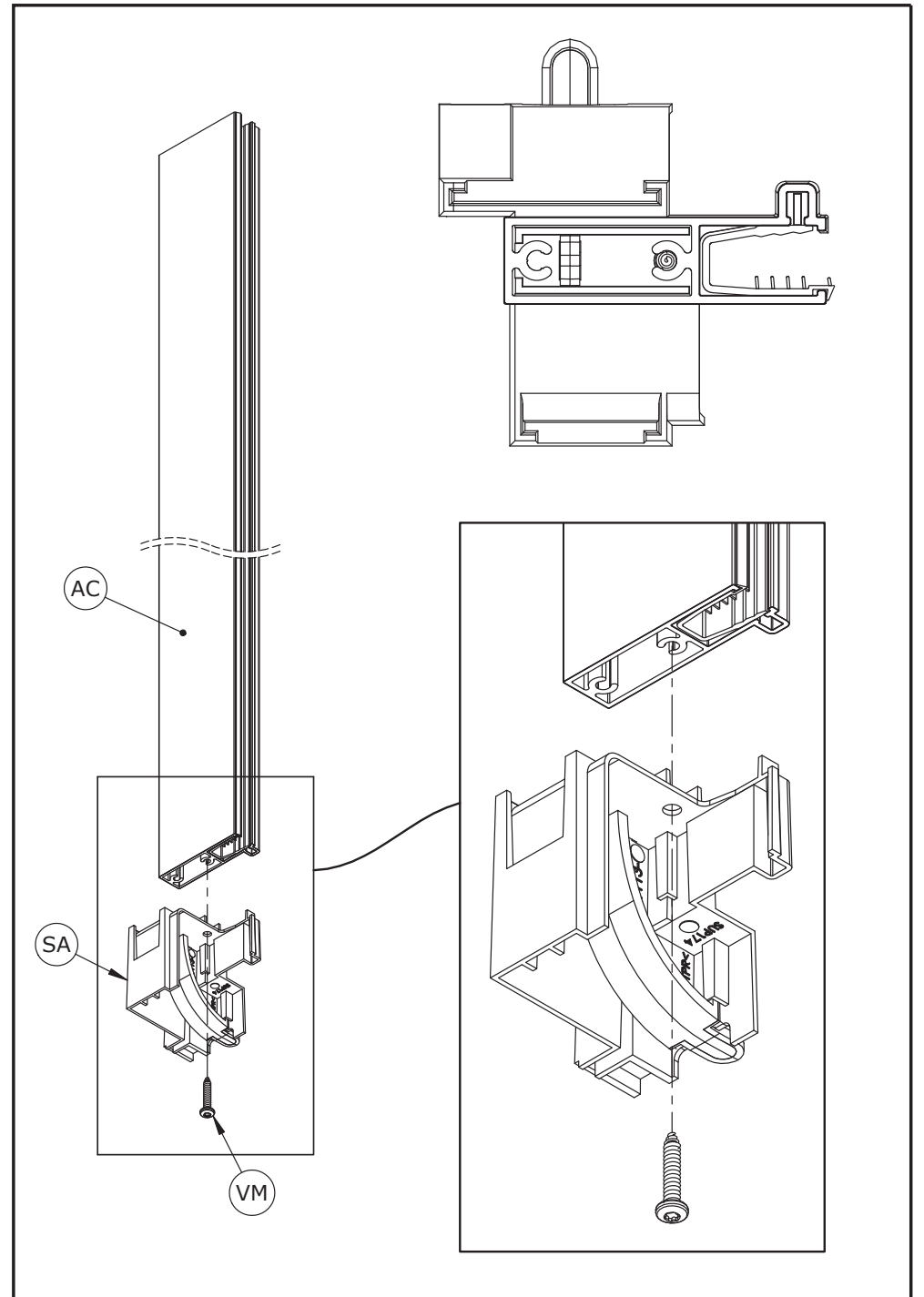
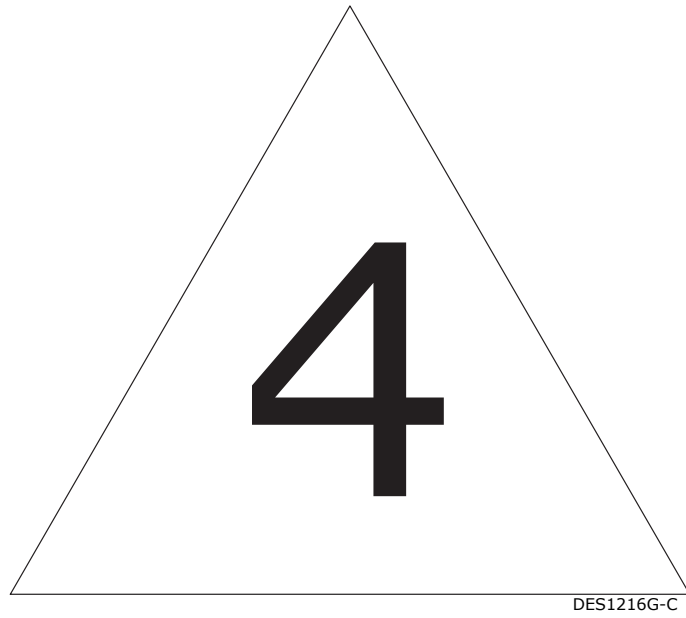

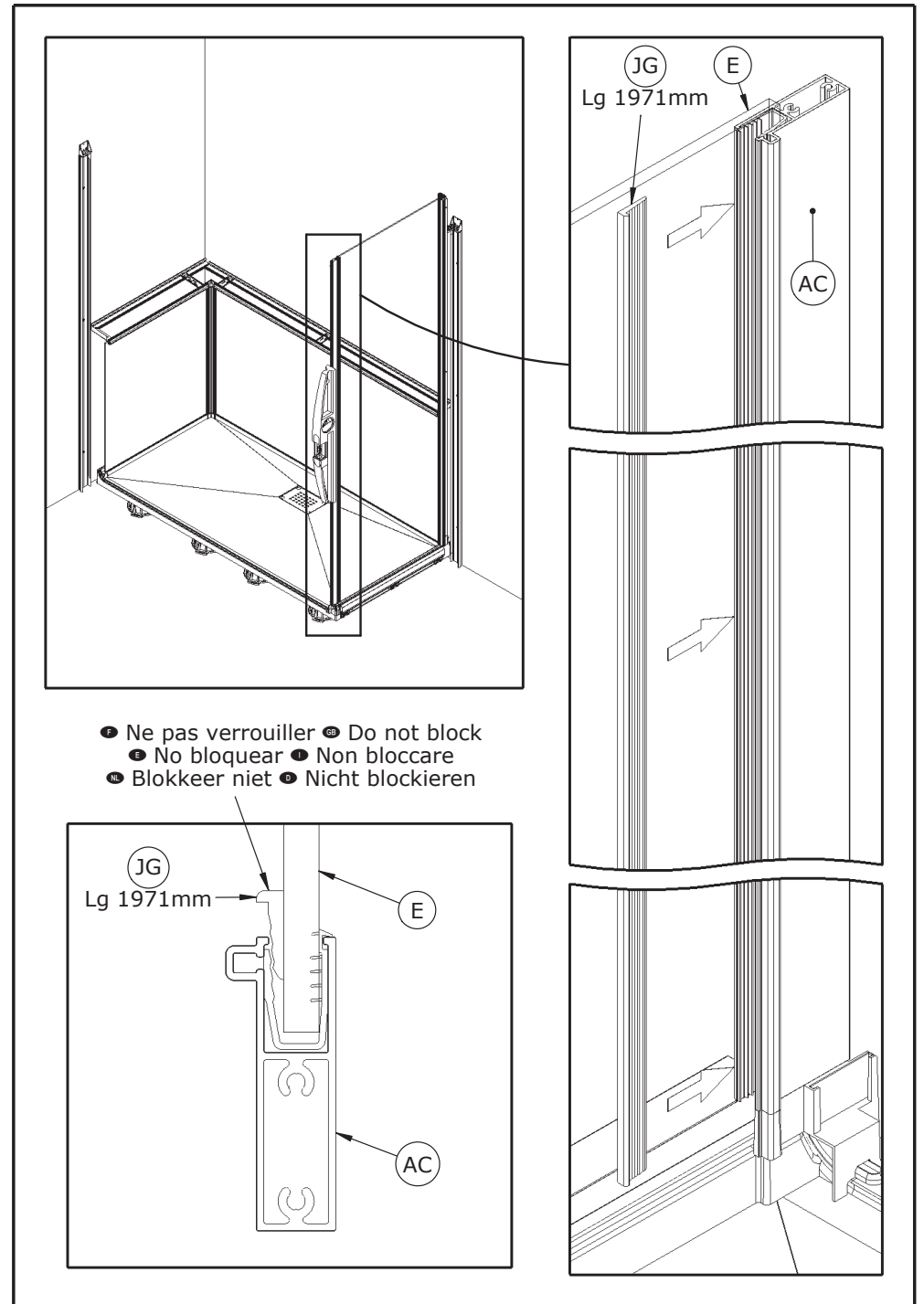
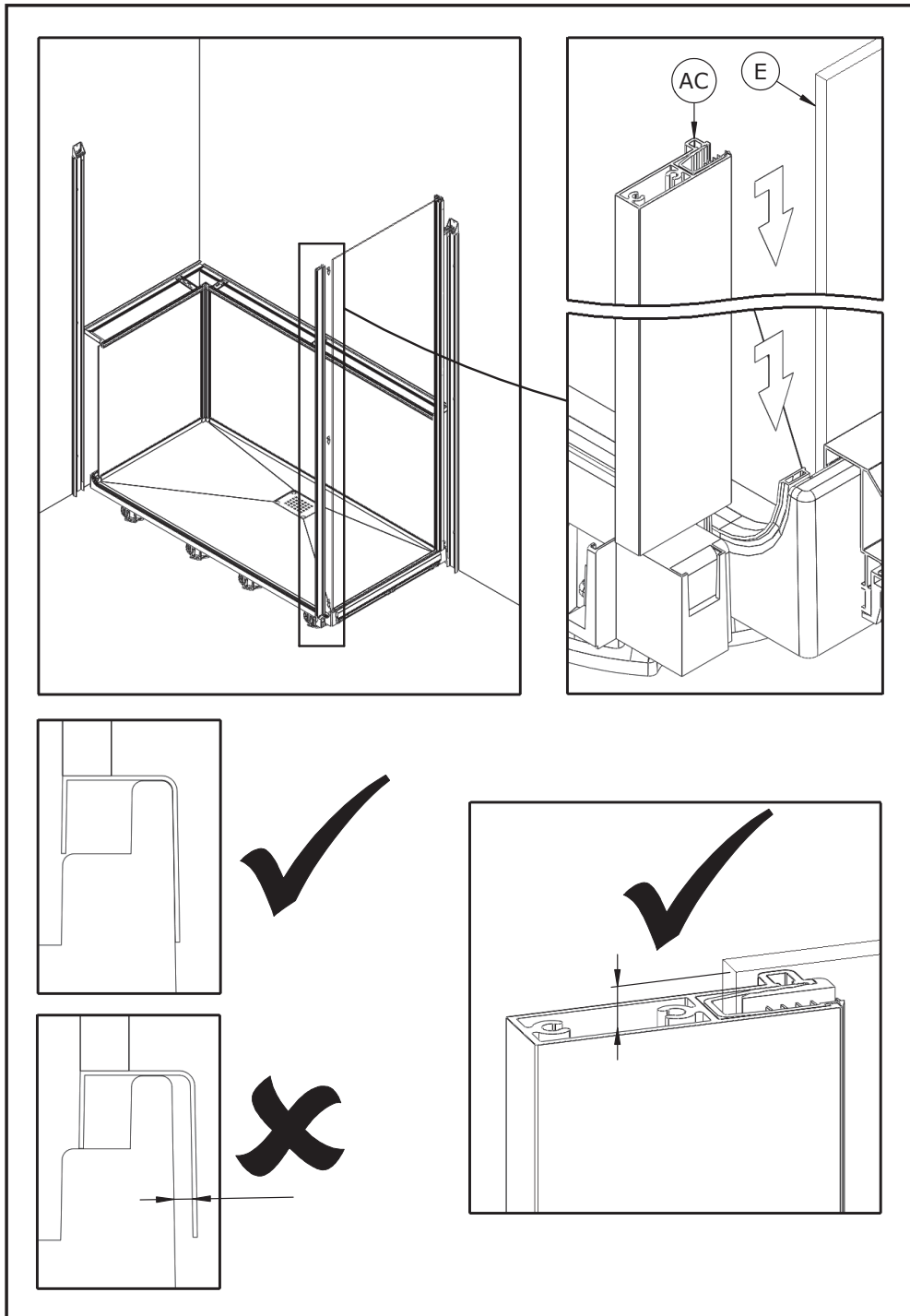

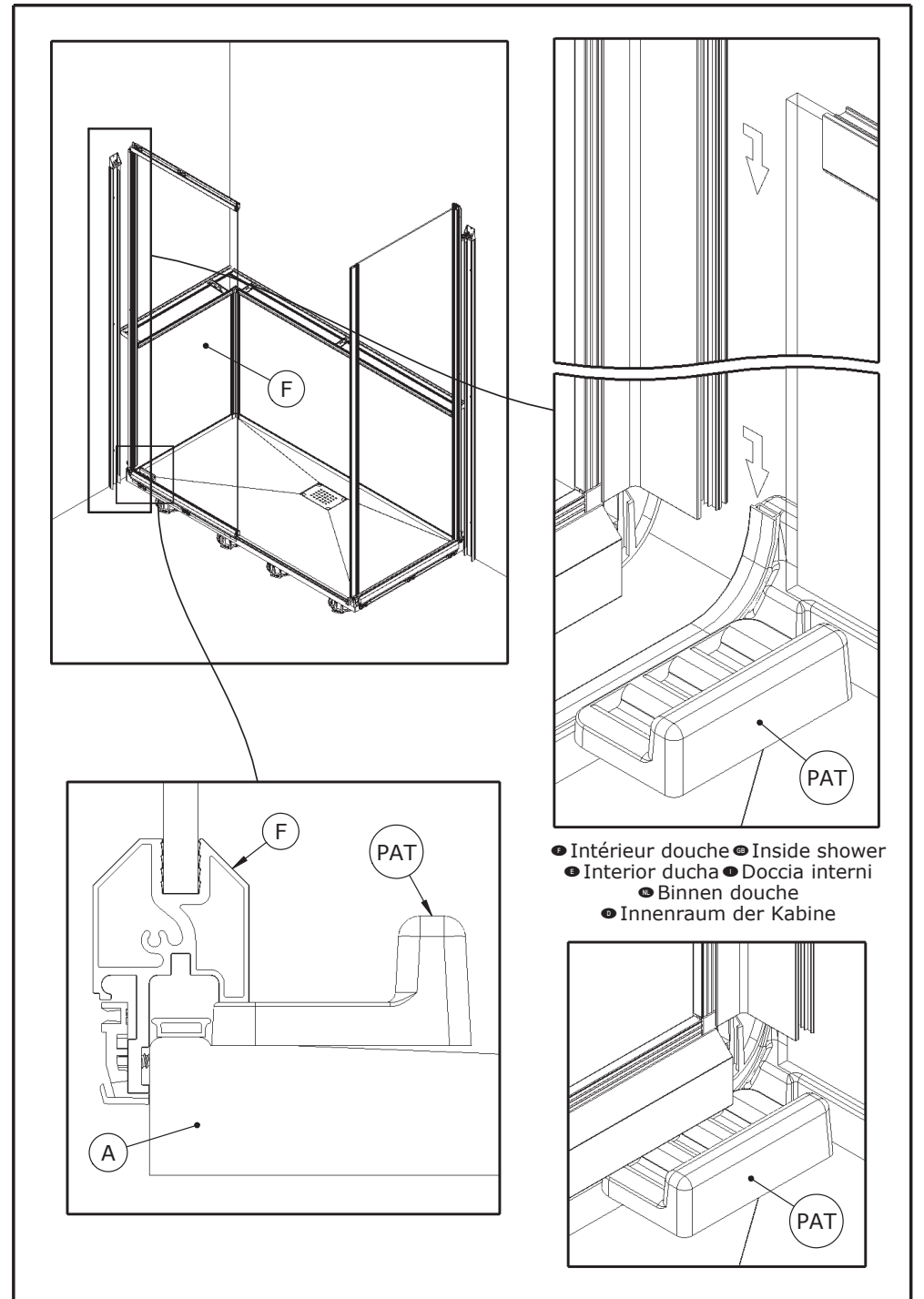
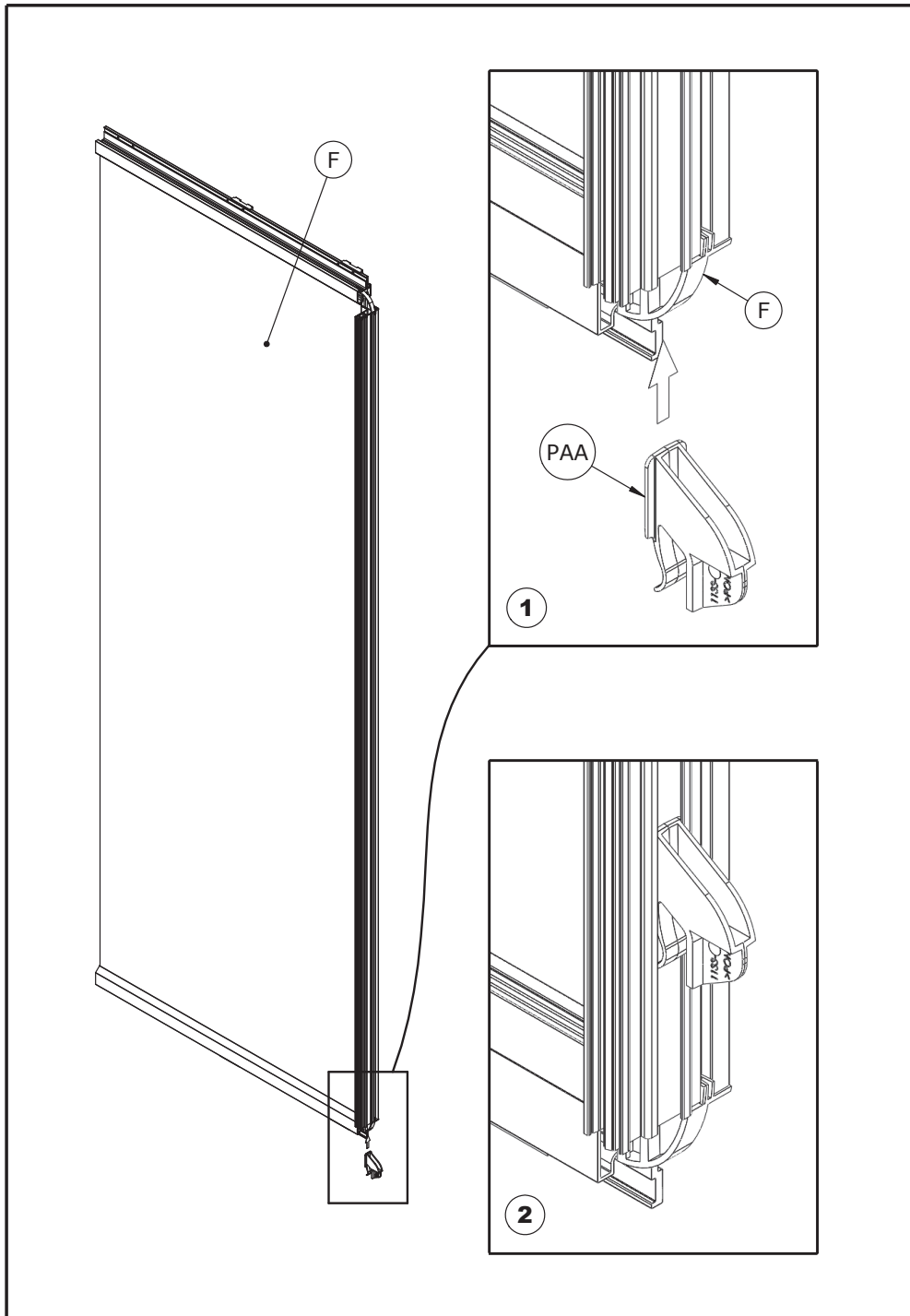

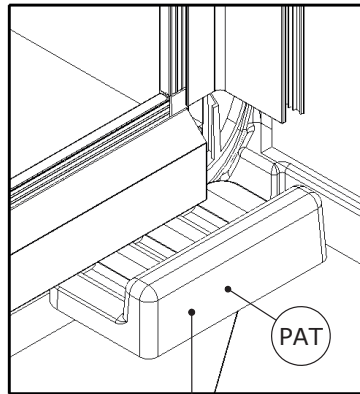
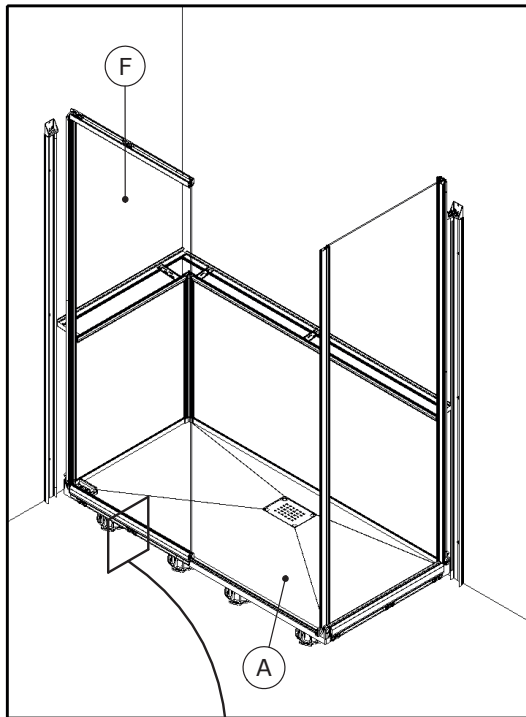

- Retirer ● Remove
- Quitar ● Togliere
- Verwijderen
- Entfernen

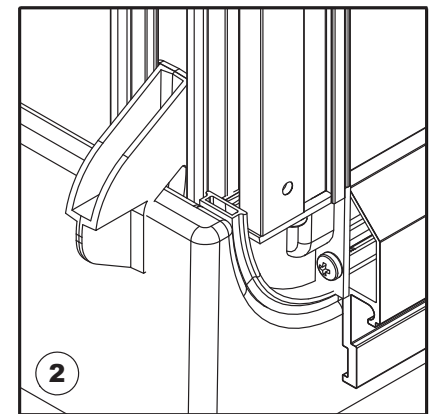
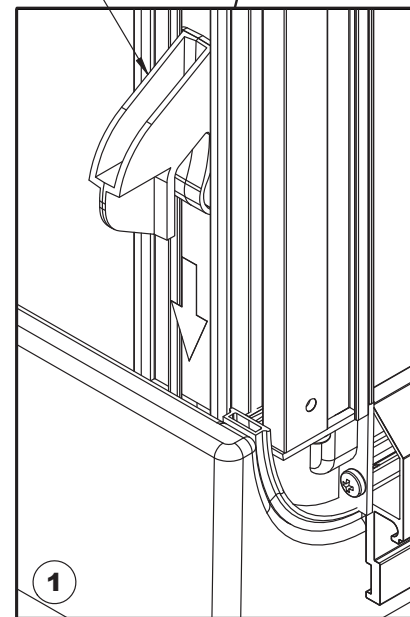
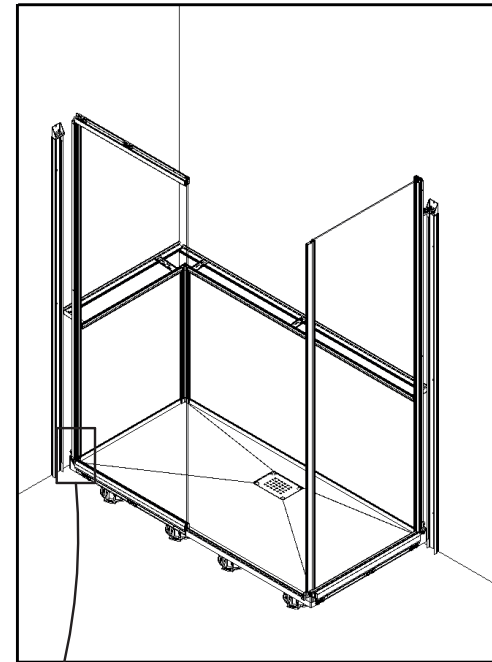
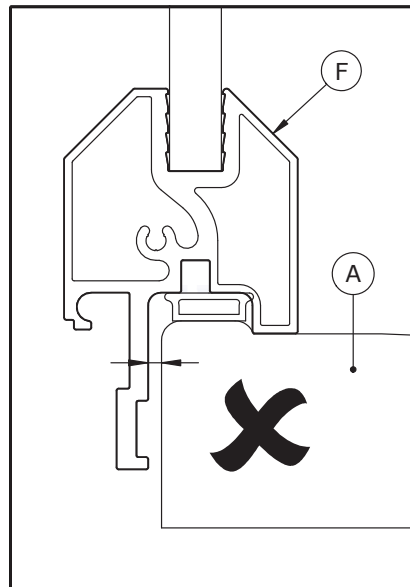
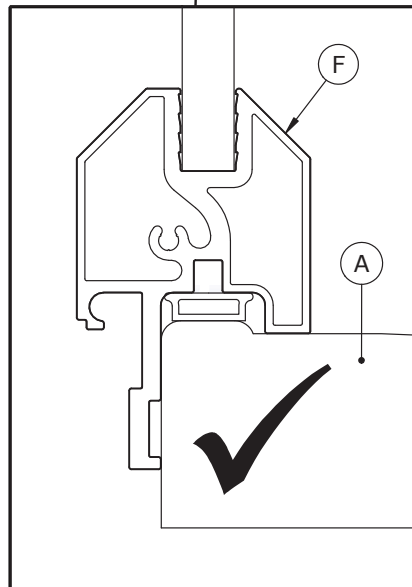

- Vue de derrière ● Back view
- Vista trasera ● Vista posteriore
- Zicht naar achteren ● Rückansicht

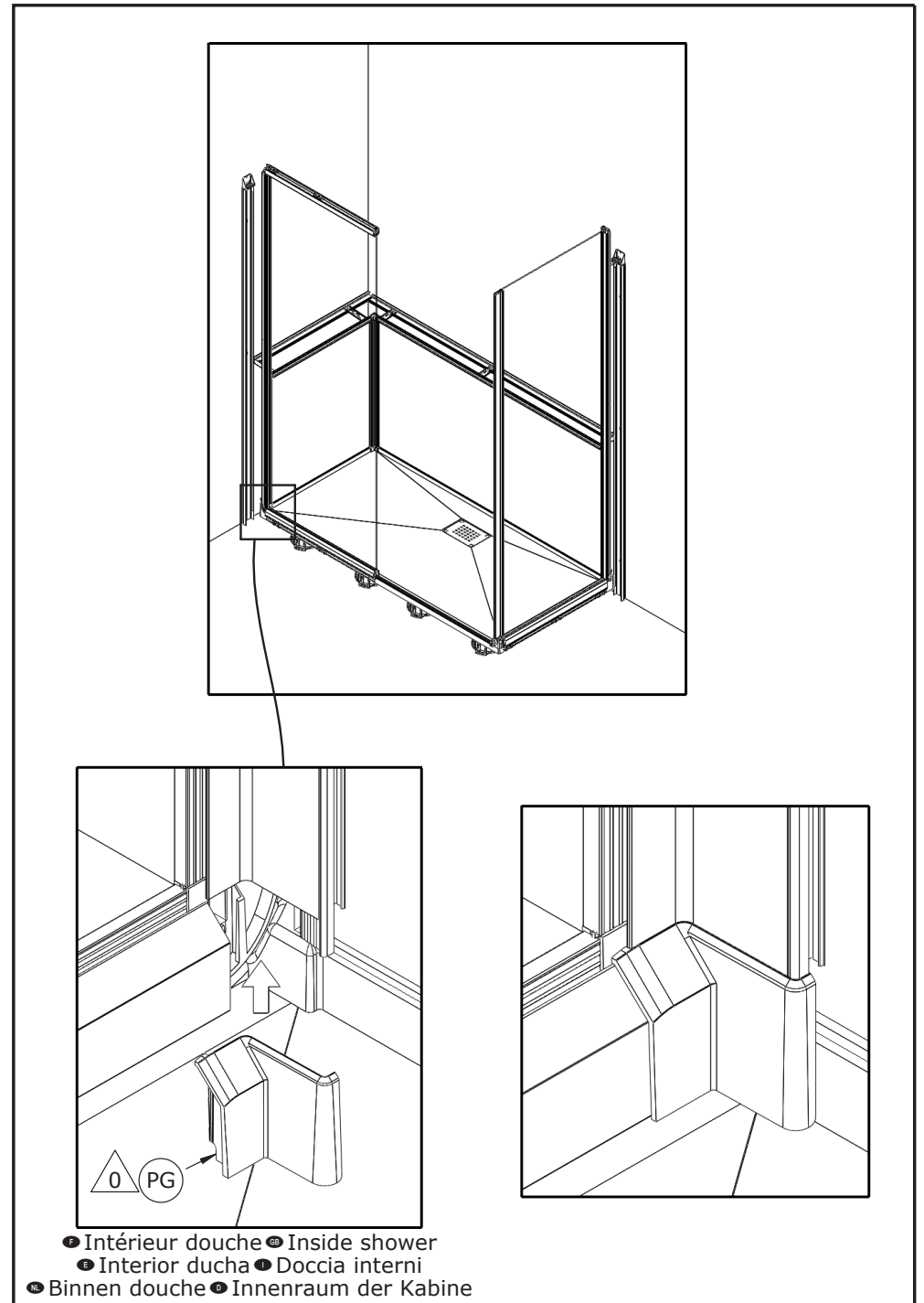
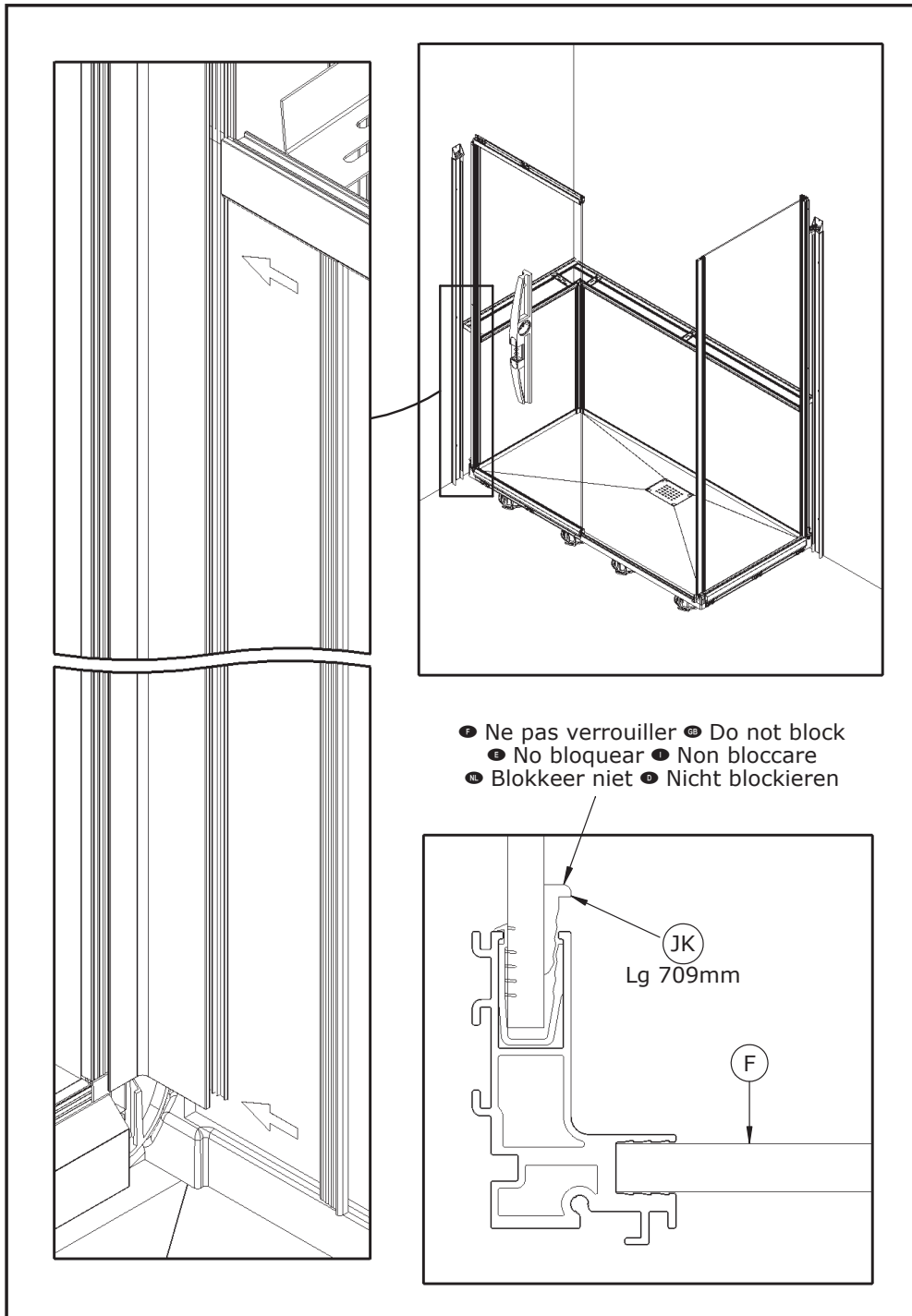

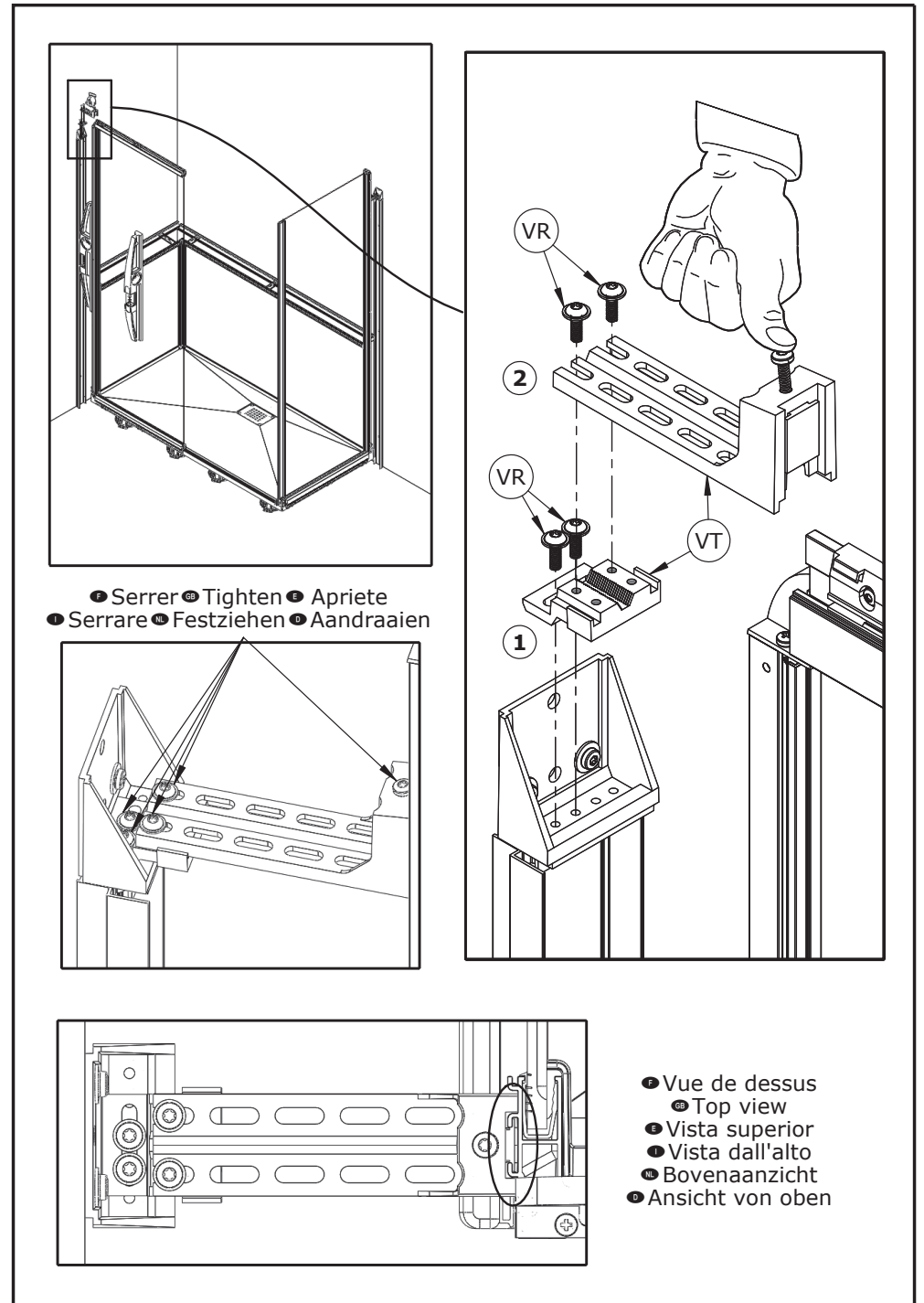
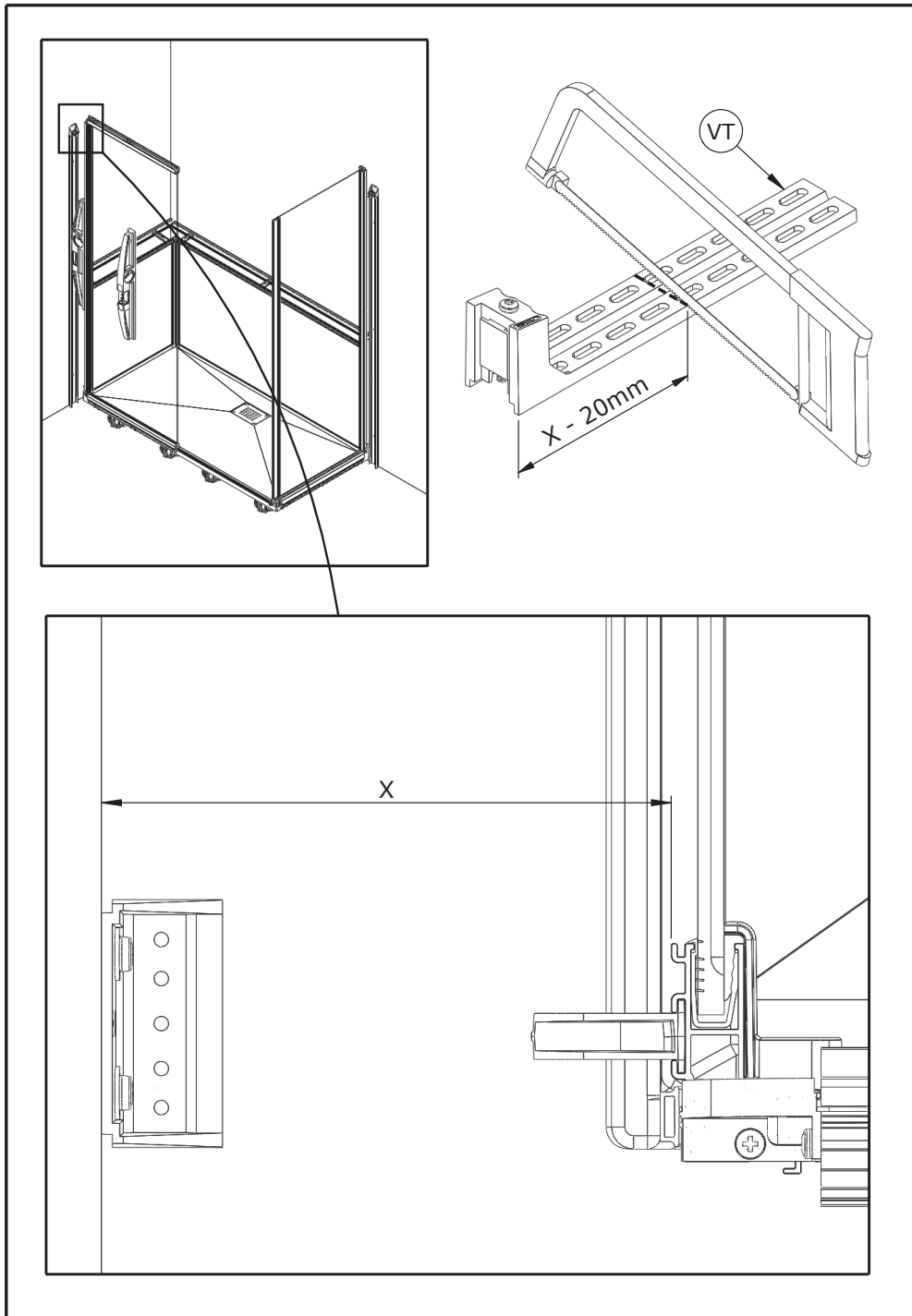

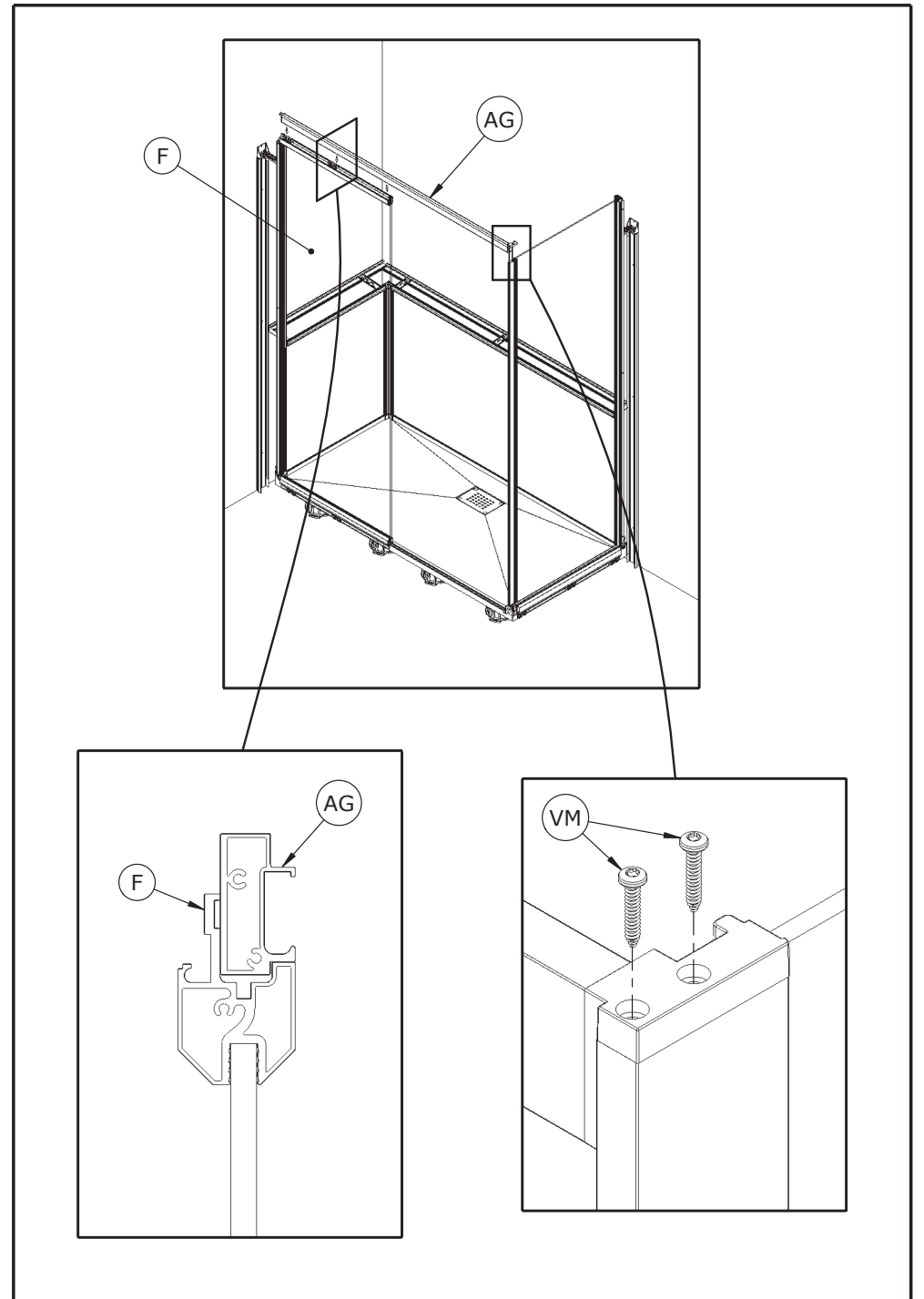
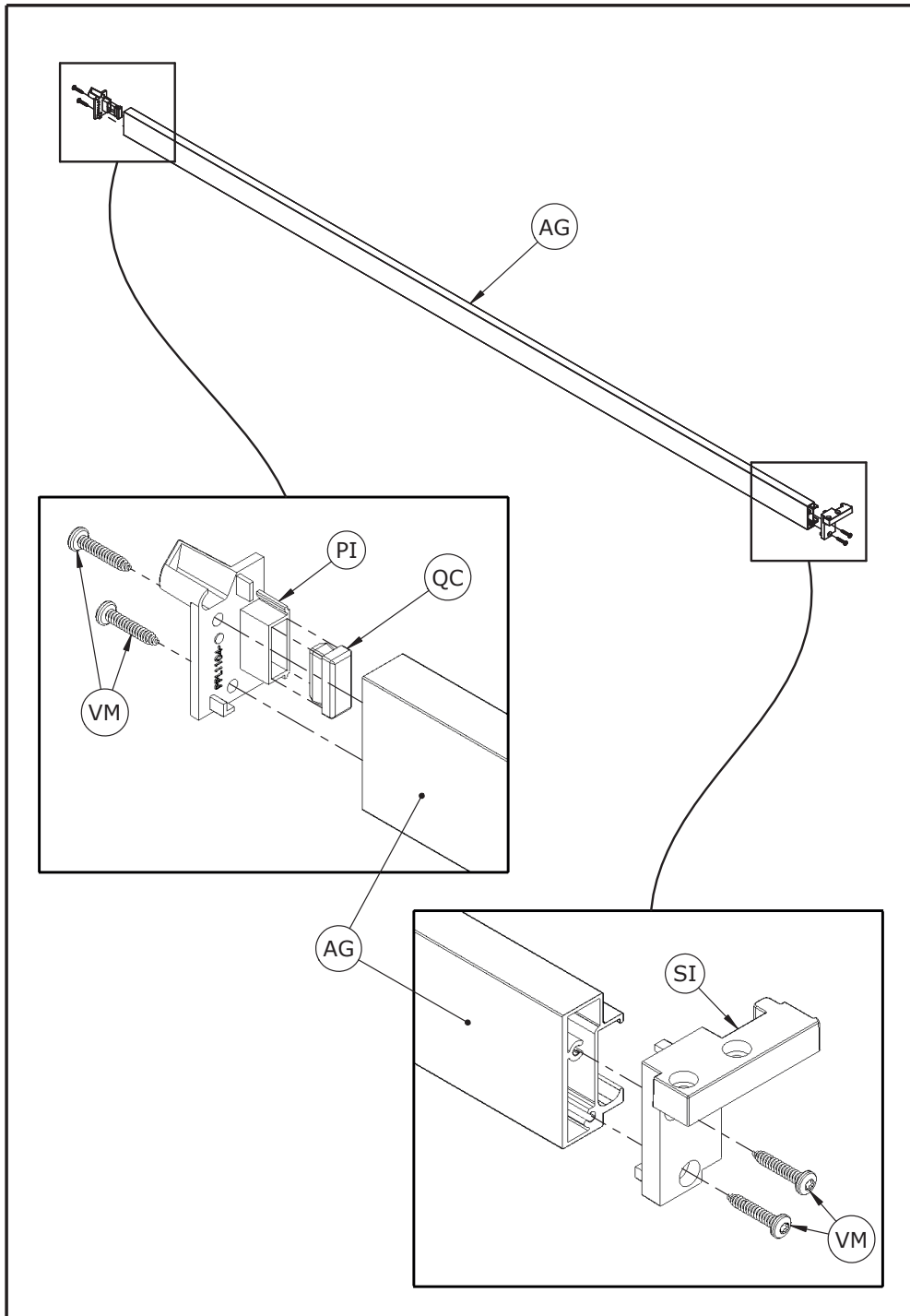

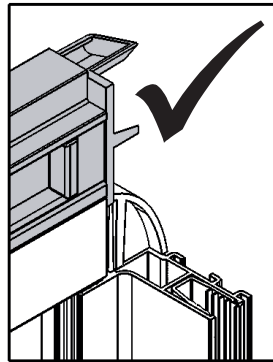
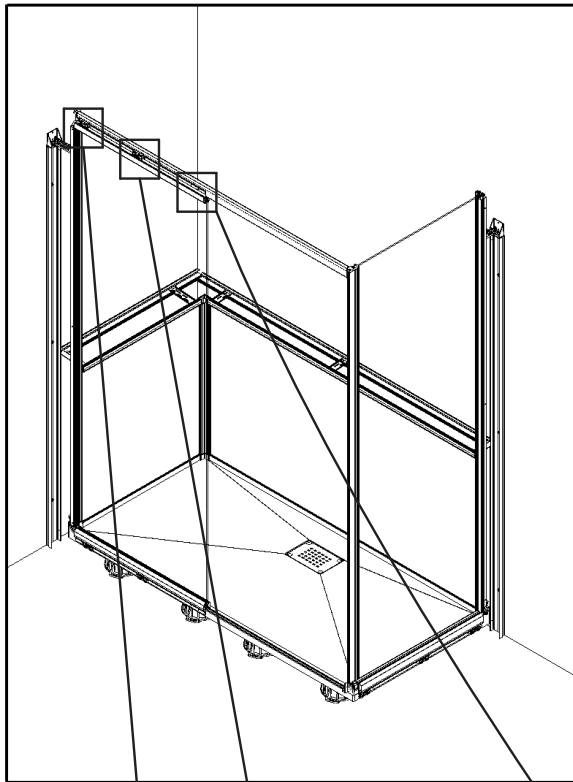

- Intérieur douche • Inside shower
- Interior ducha • Doccia interni
- Binnen douche
- Innenraum der Kabine

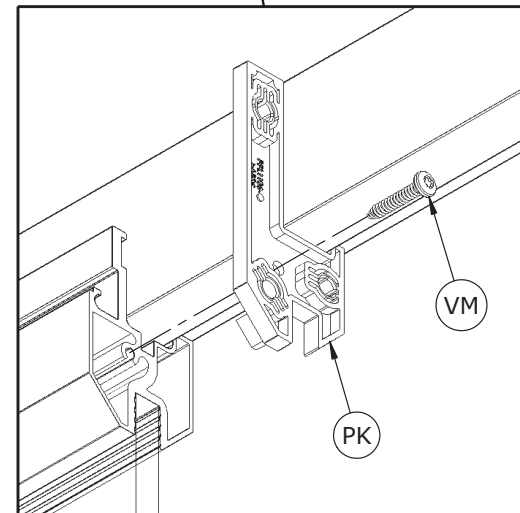
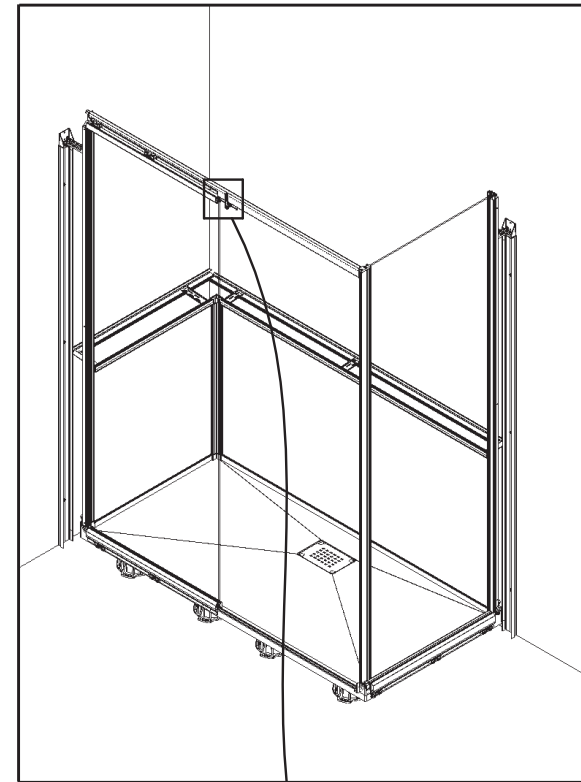
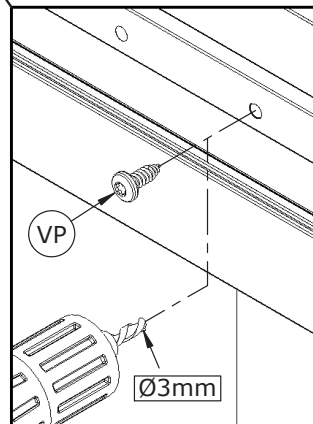
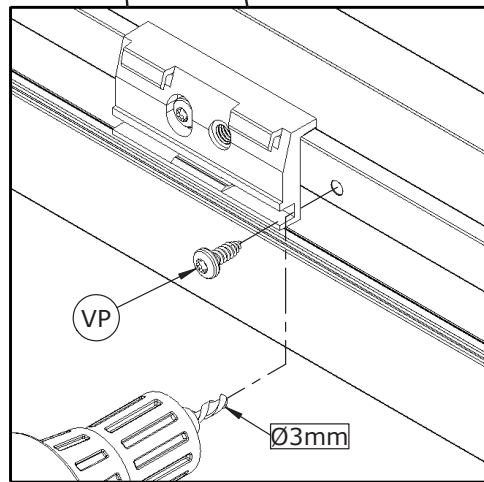
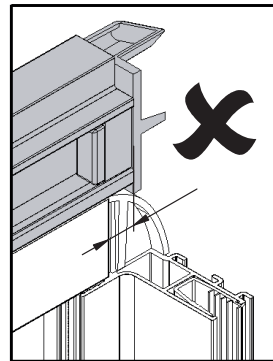

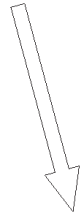
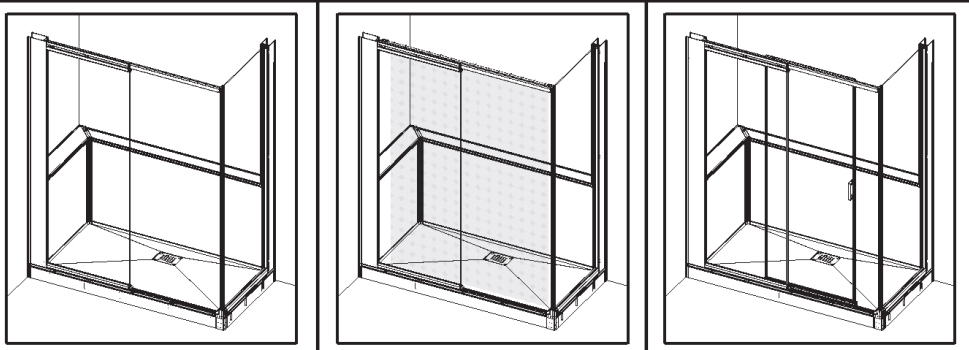

- Page suivante
- Next page
- Página siguiente
- Pagina seguente
- Volgende bladzijde
- Nächste Seite

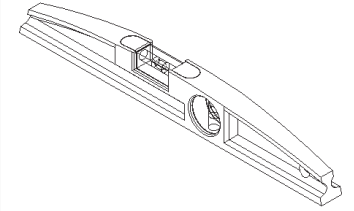
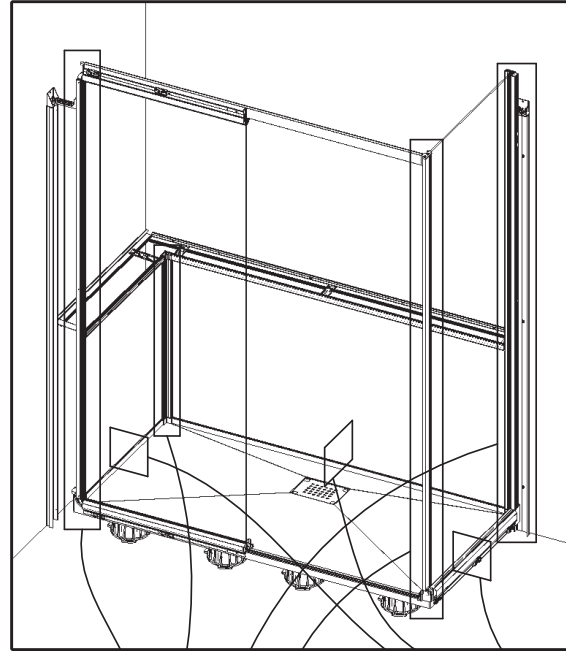
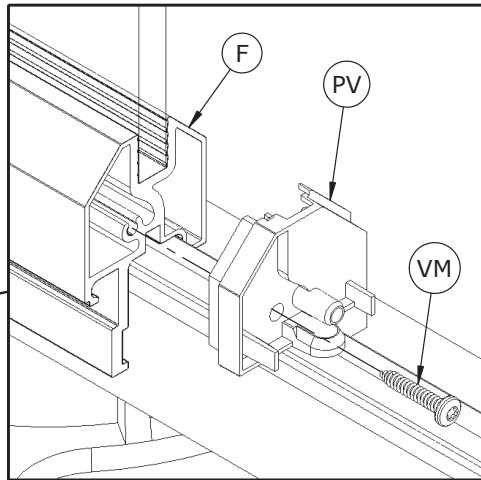
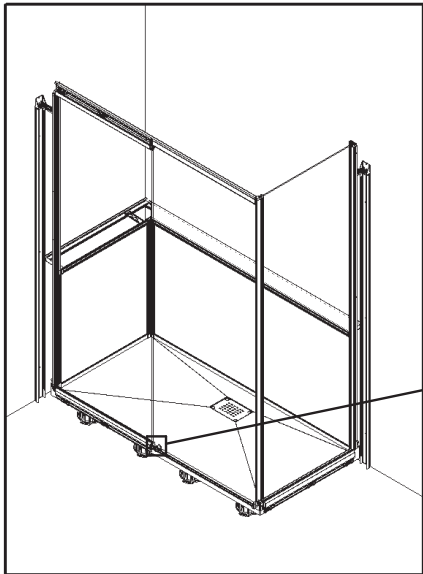

- Vérifier l'aplomb de la cabine, puis verrouiller
- Ensure level then block
- Verificar la verticalidad de la cabina, y bloquear
- Assicurarsi che la doccia è di livello, e bloccare
- Controleer of de douchecabine goed recht staat, en blokkeer
- Prüfen, ob die Kabine lotrecht steht, anschließend blockieren

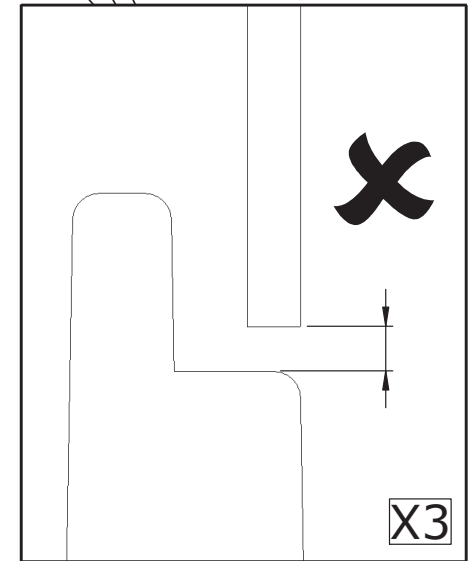
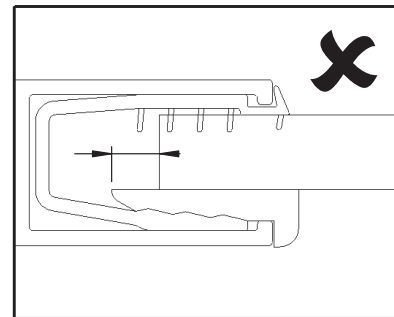
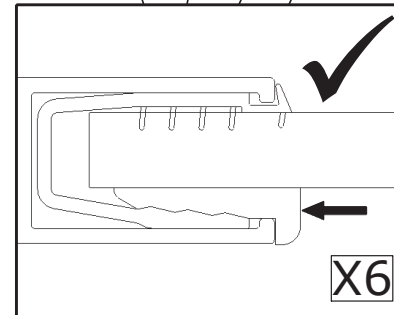

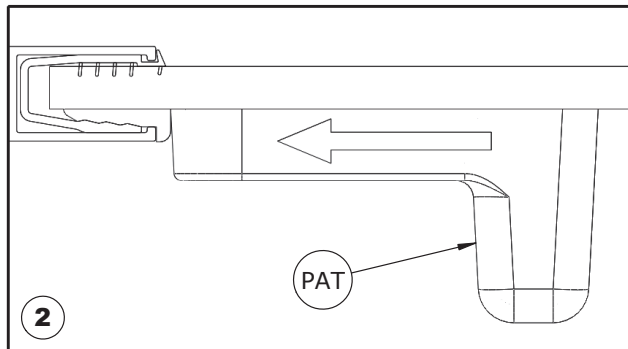
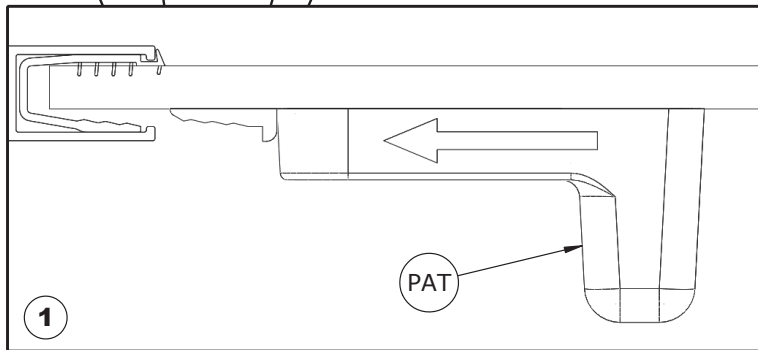
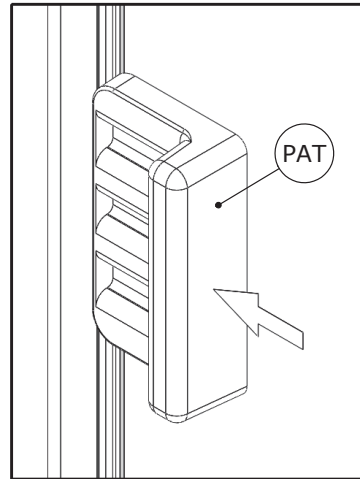
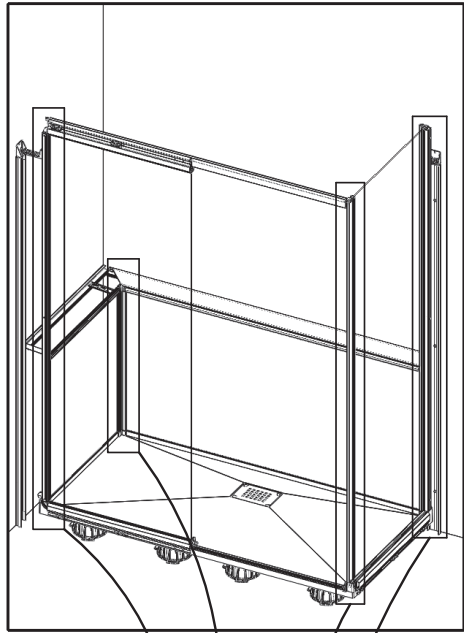



- Montage poignée, voir notice concernée
- Handle installation, see note concerned
- Montaje de la asa, ver manual adecuado
 - Montaggio della maniglia, vedere manuale appropriato
 - Zie voor de montage van de greep de bijbehorende montage-instructies
 - Montage des Handgriffs siehe entsprechende Anleitung

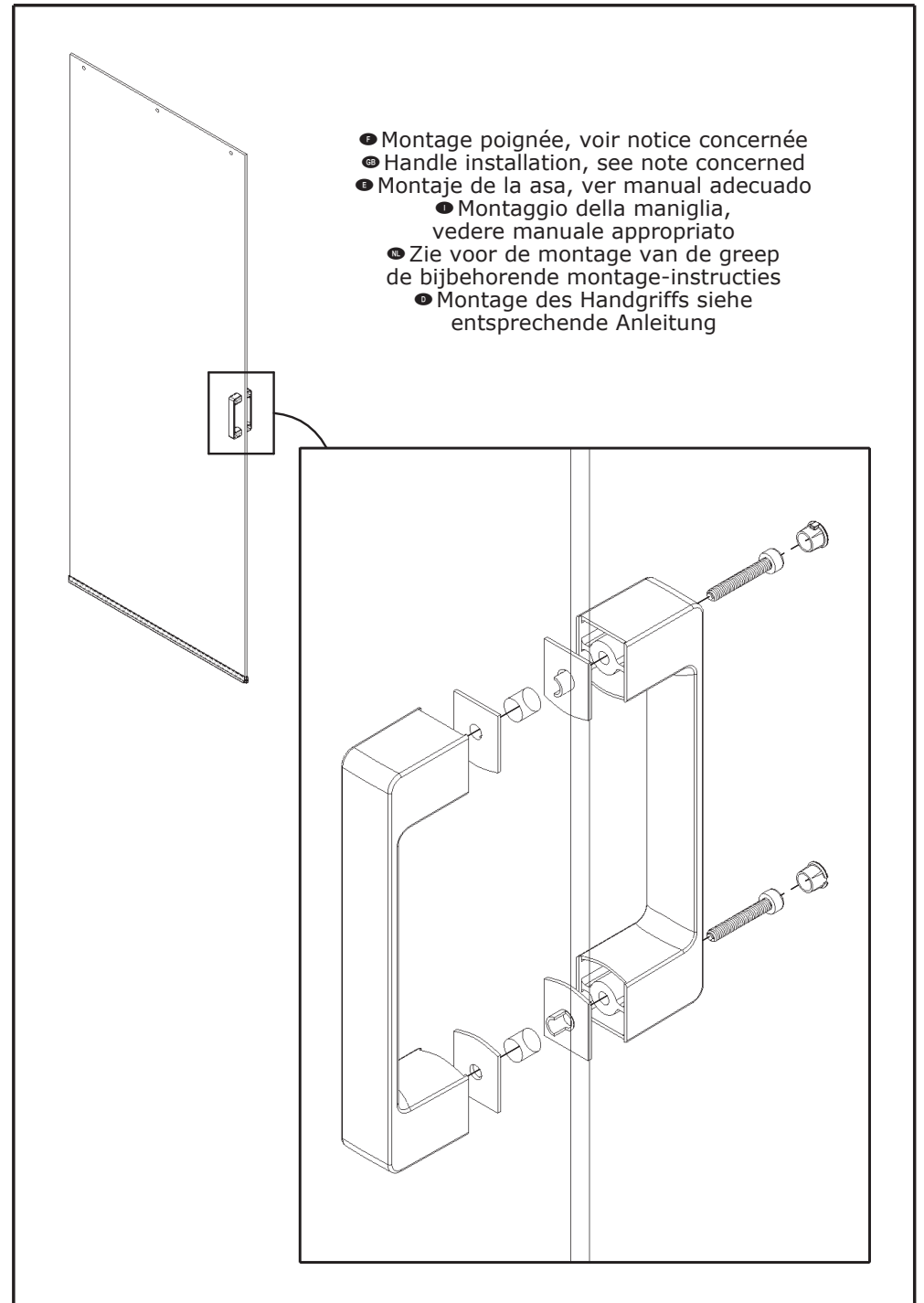

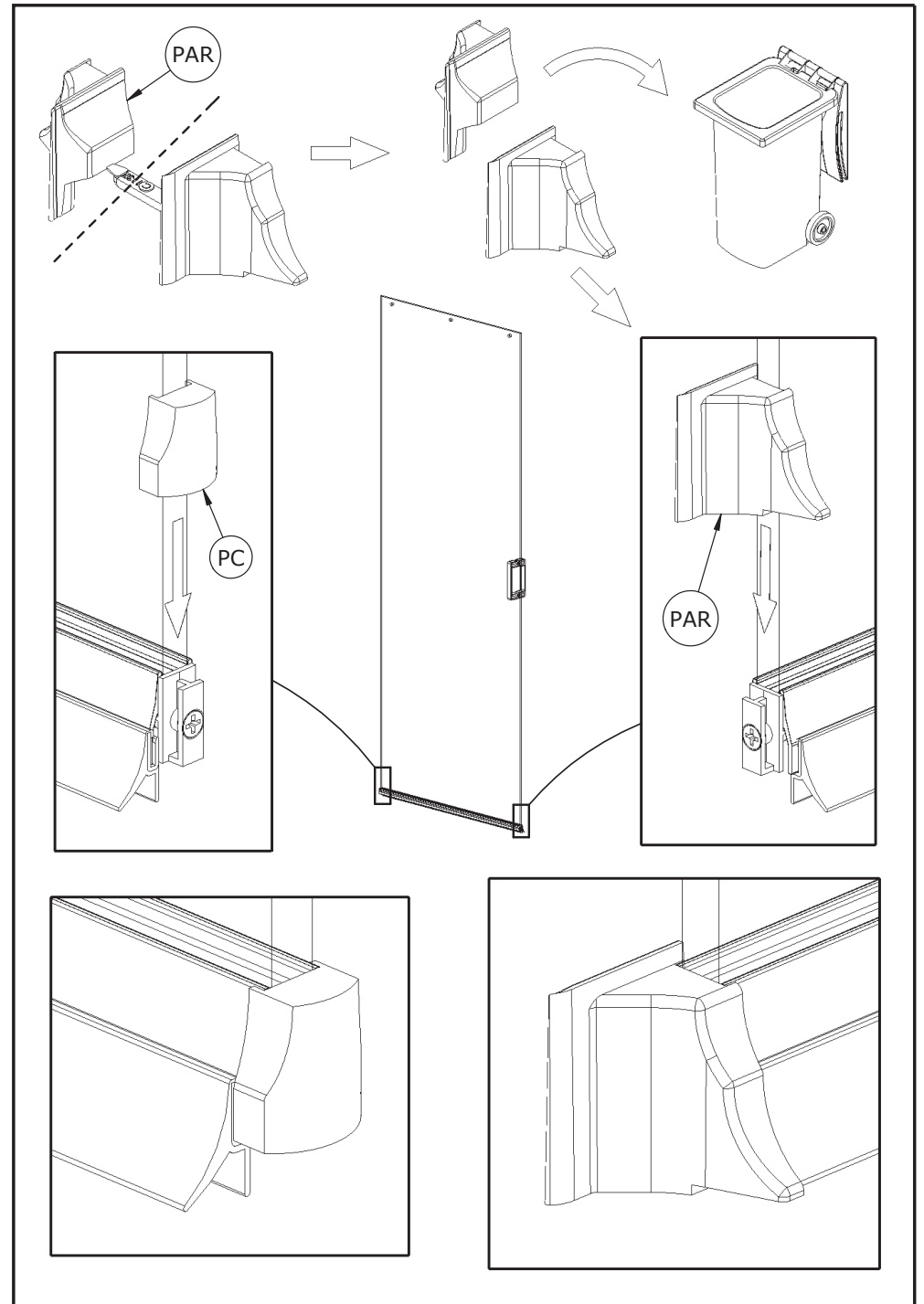
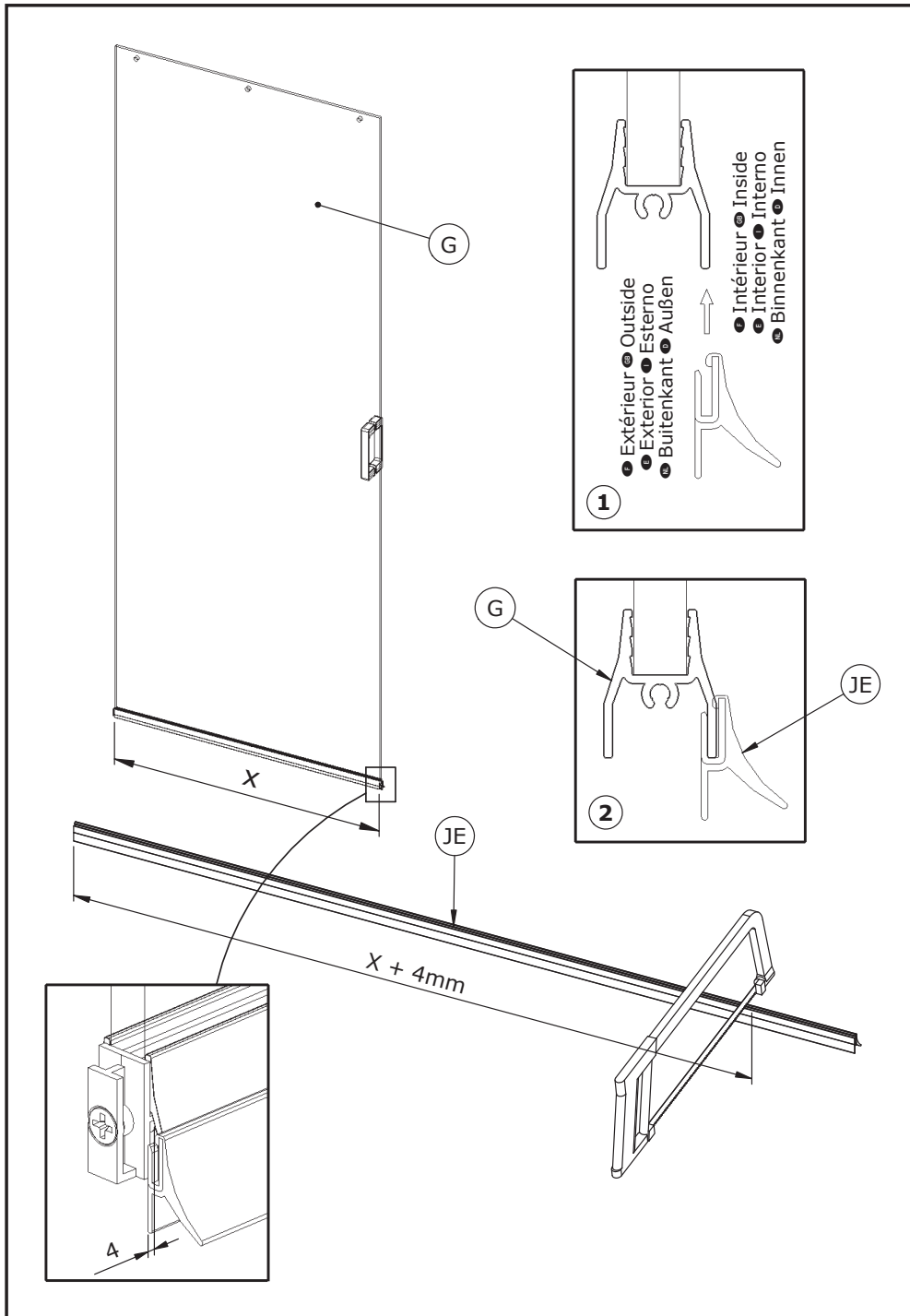

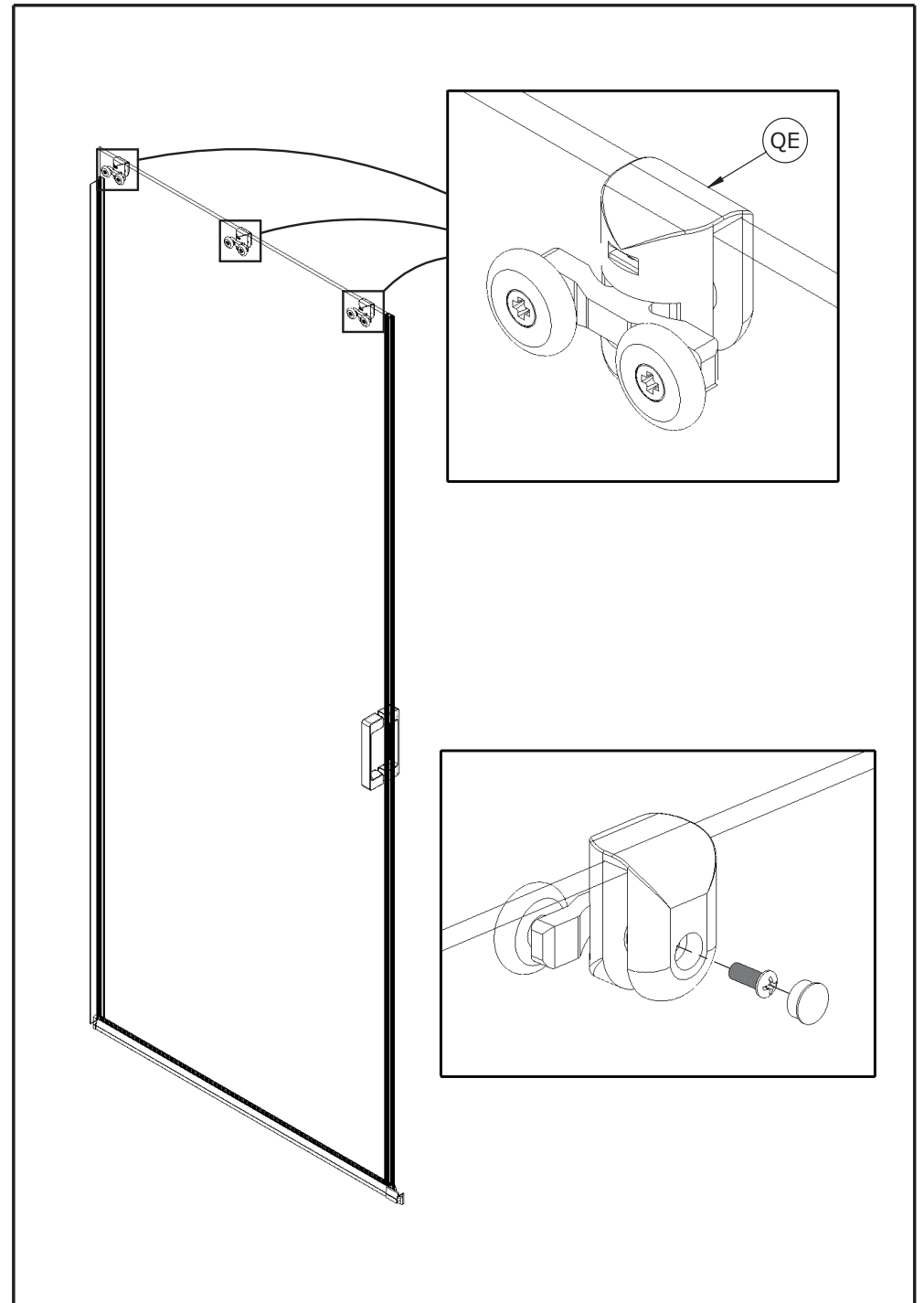
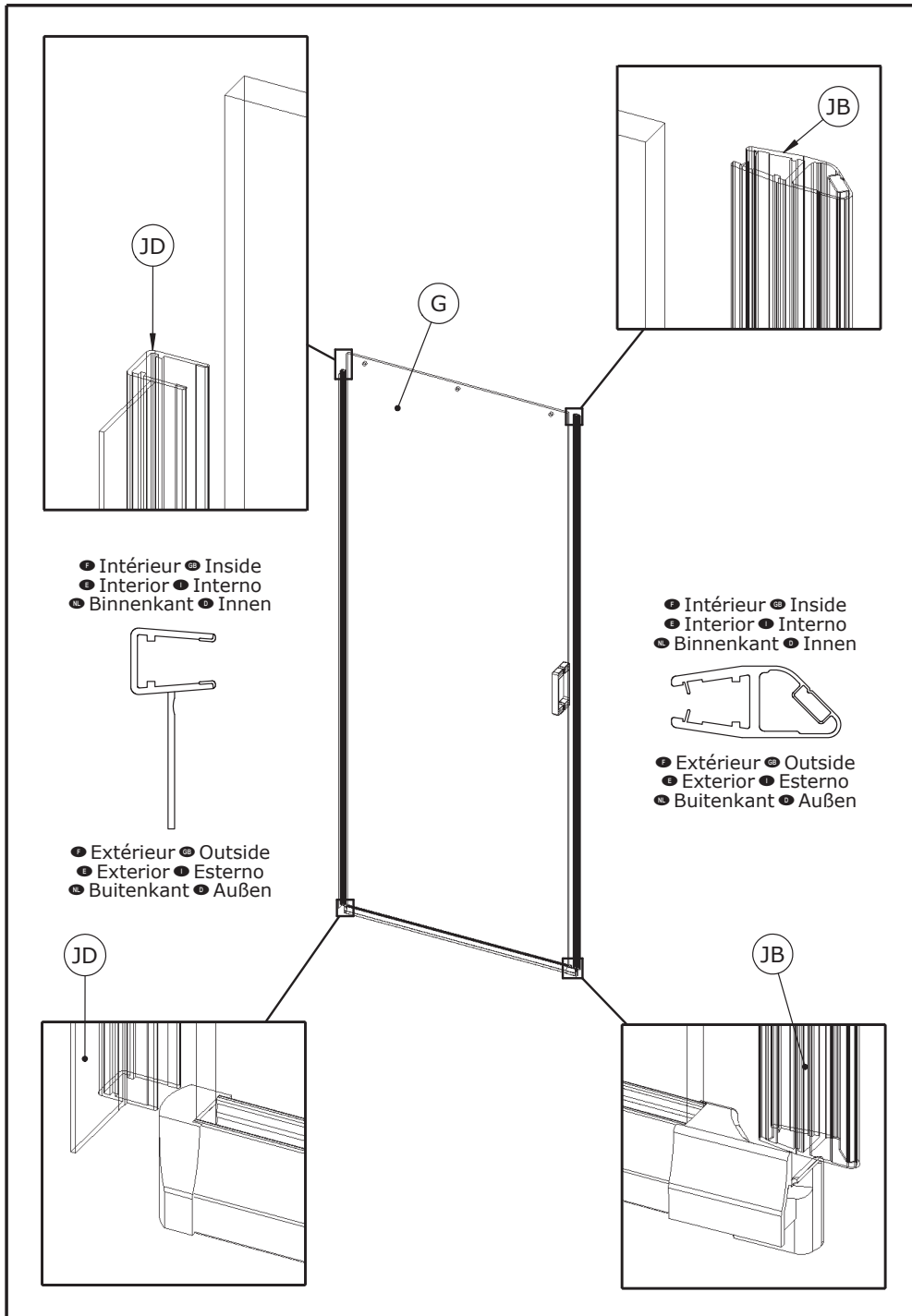

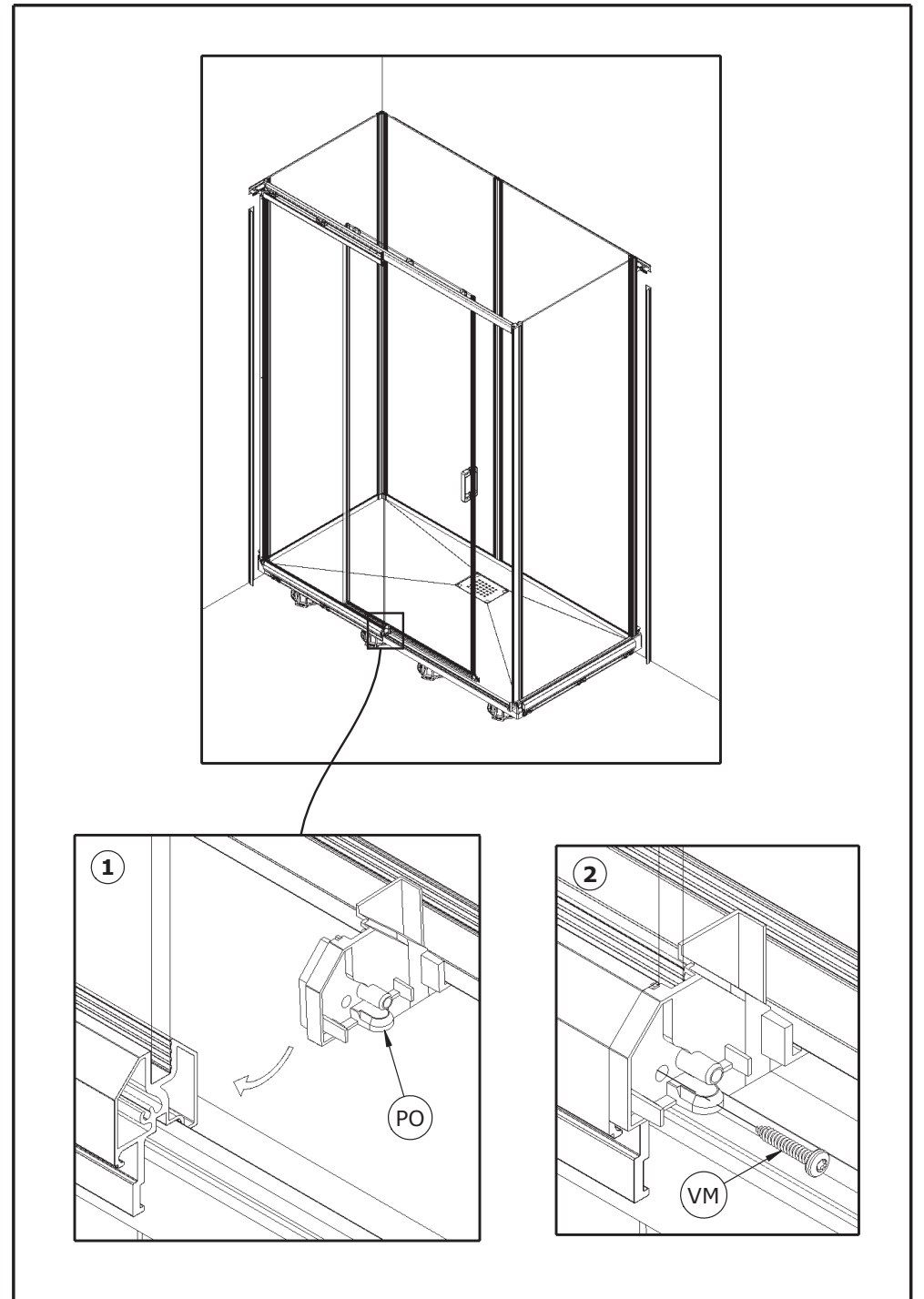
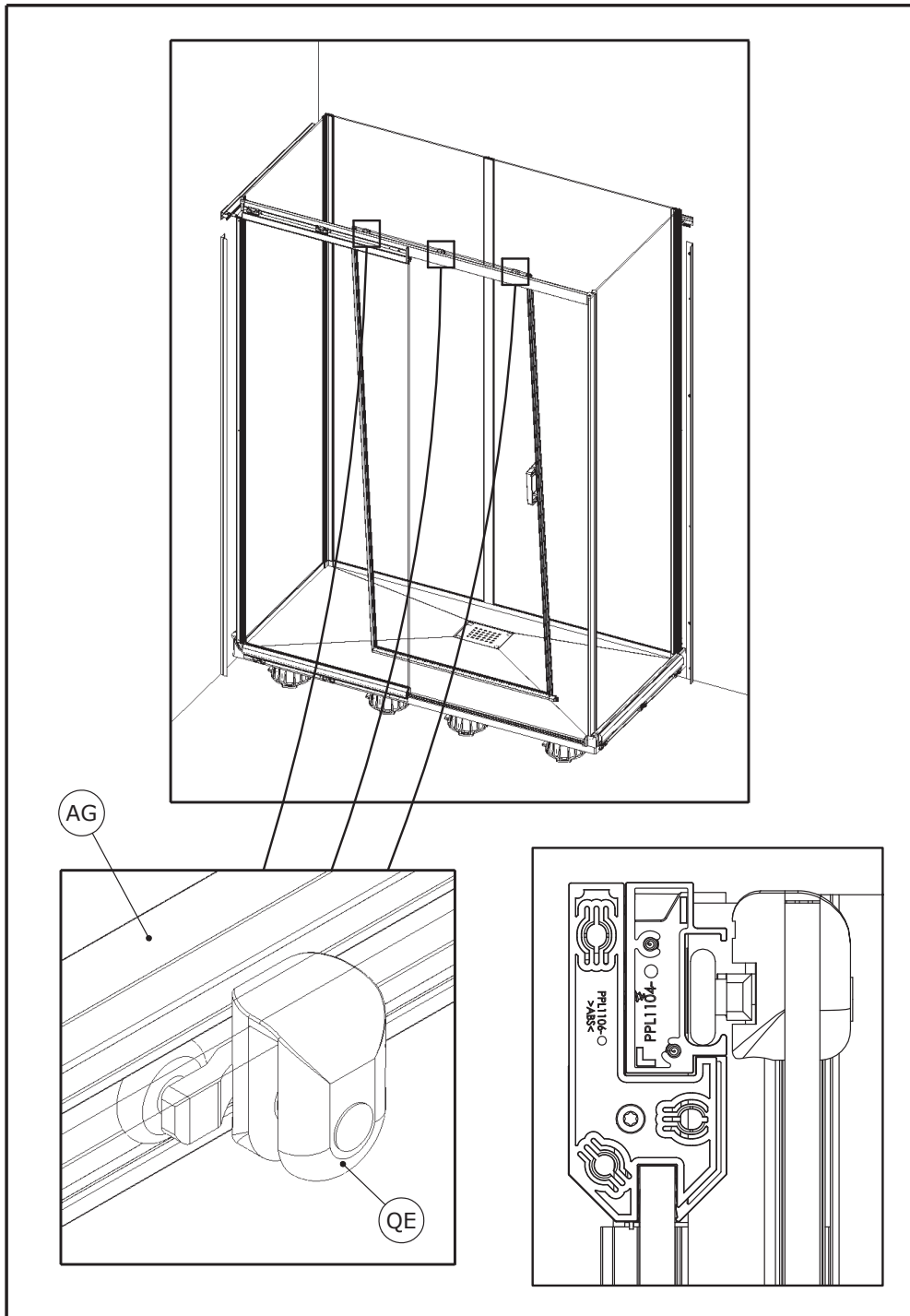

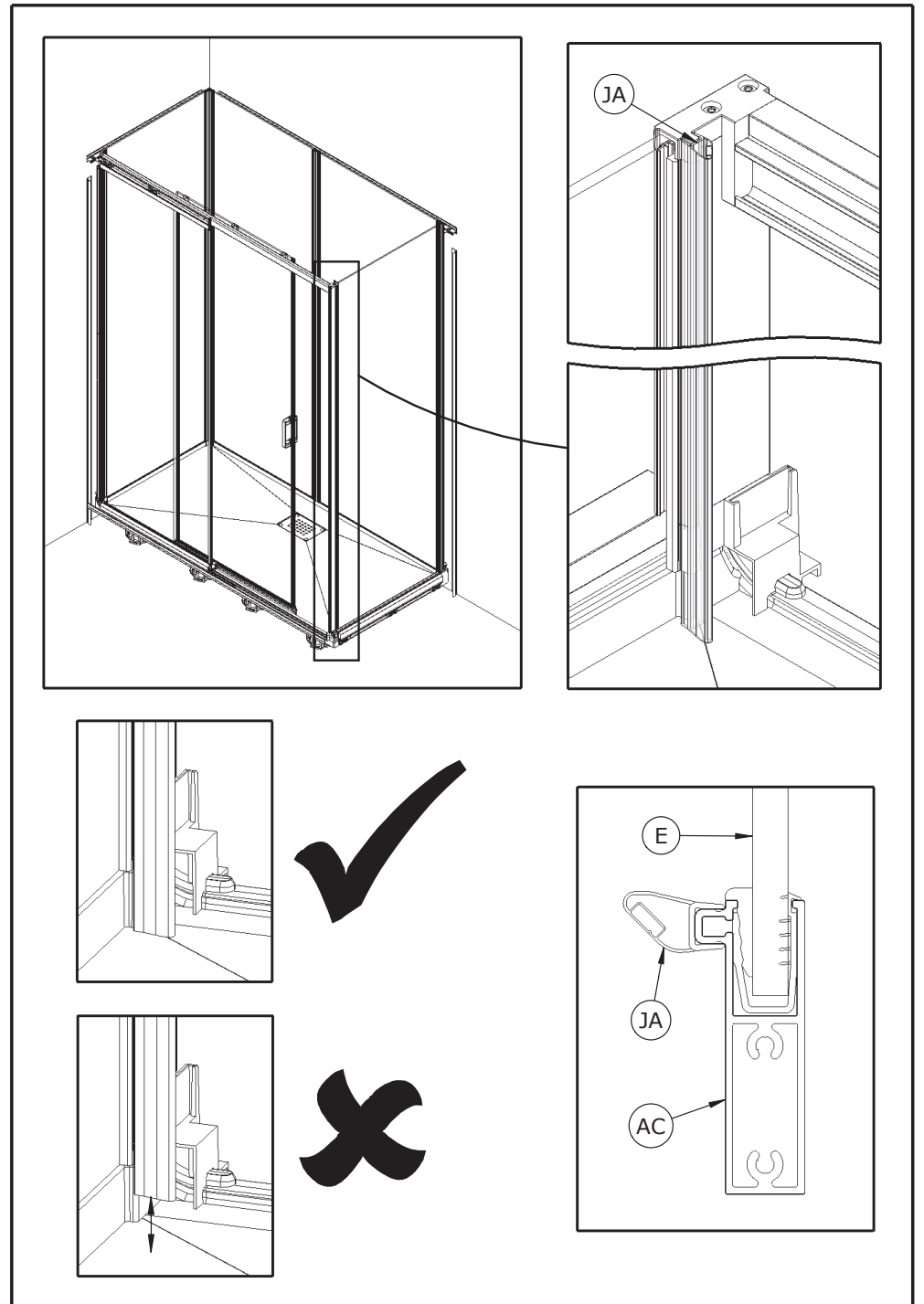
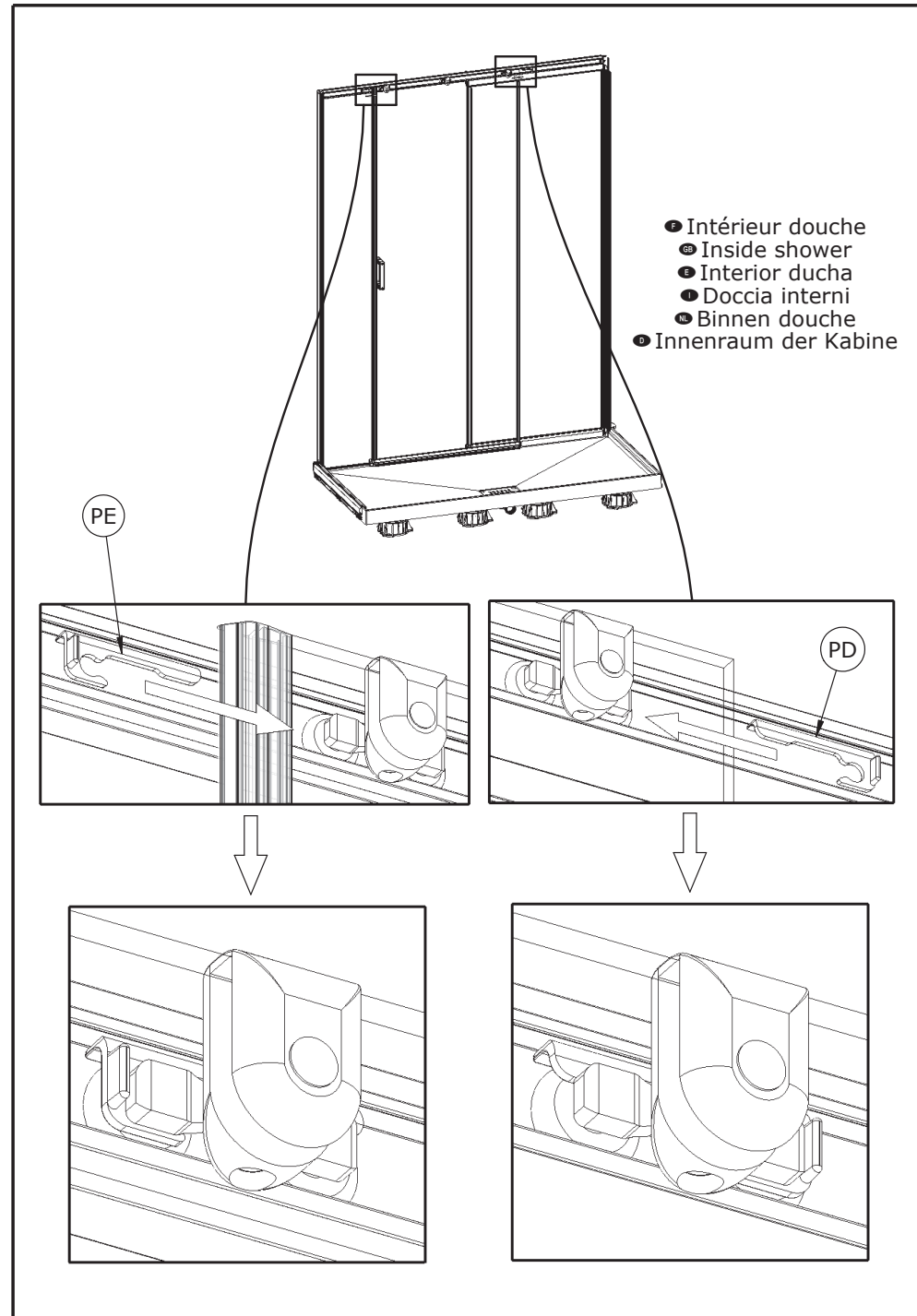

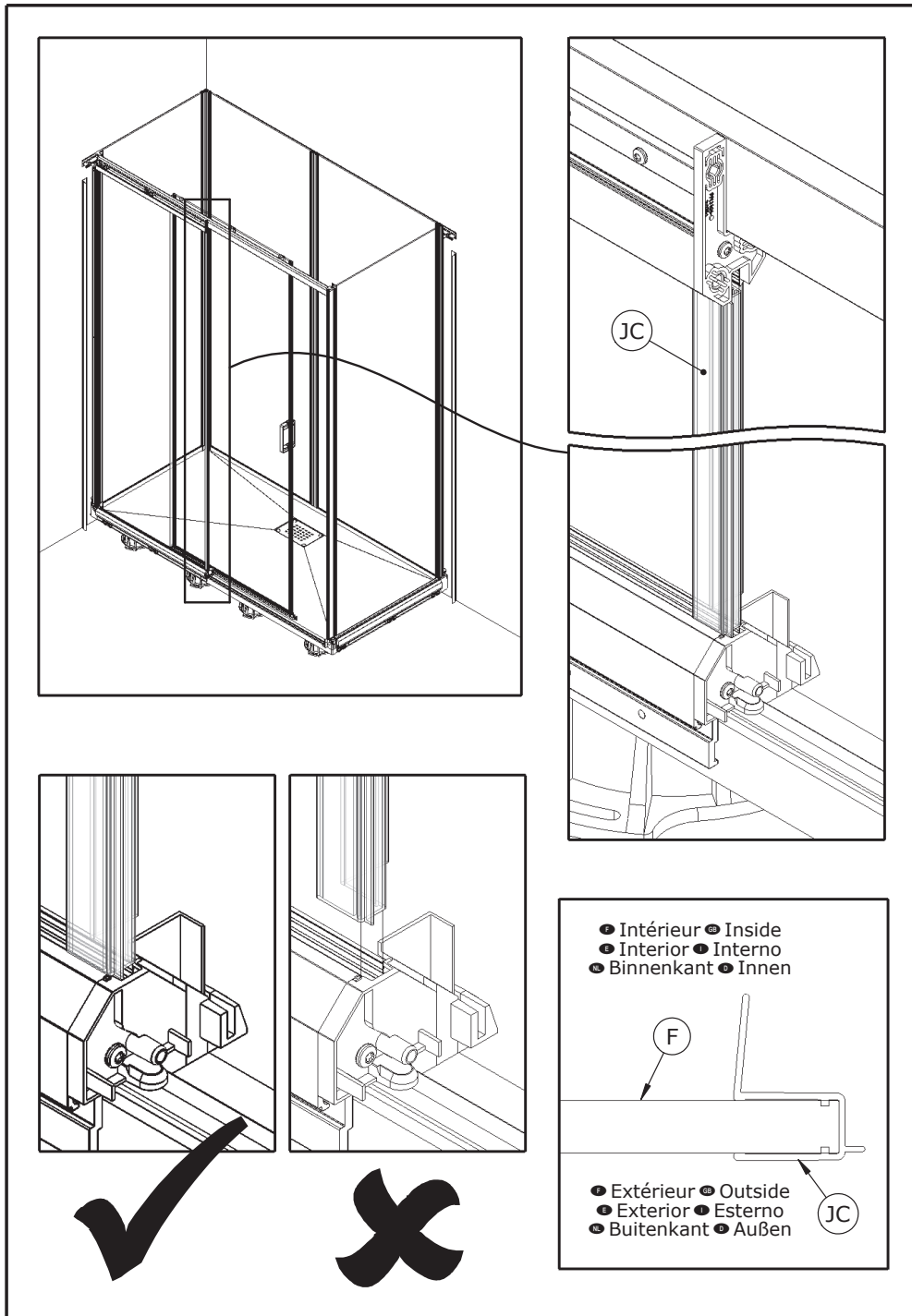

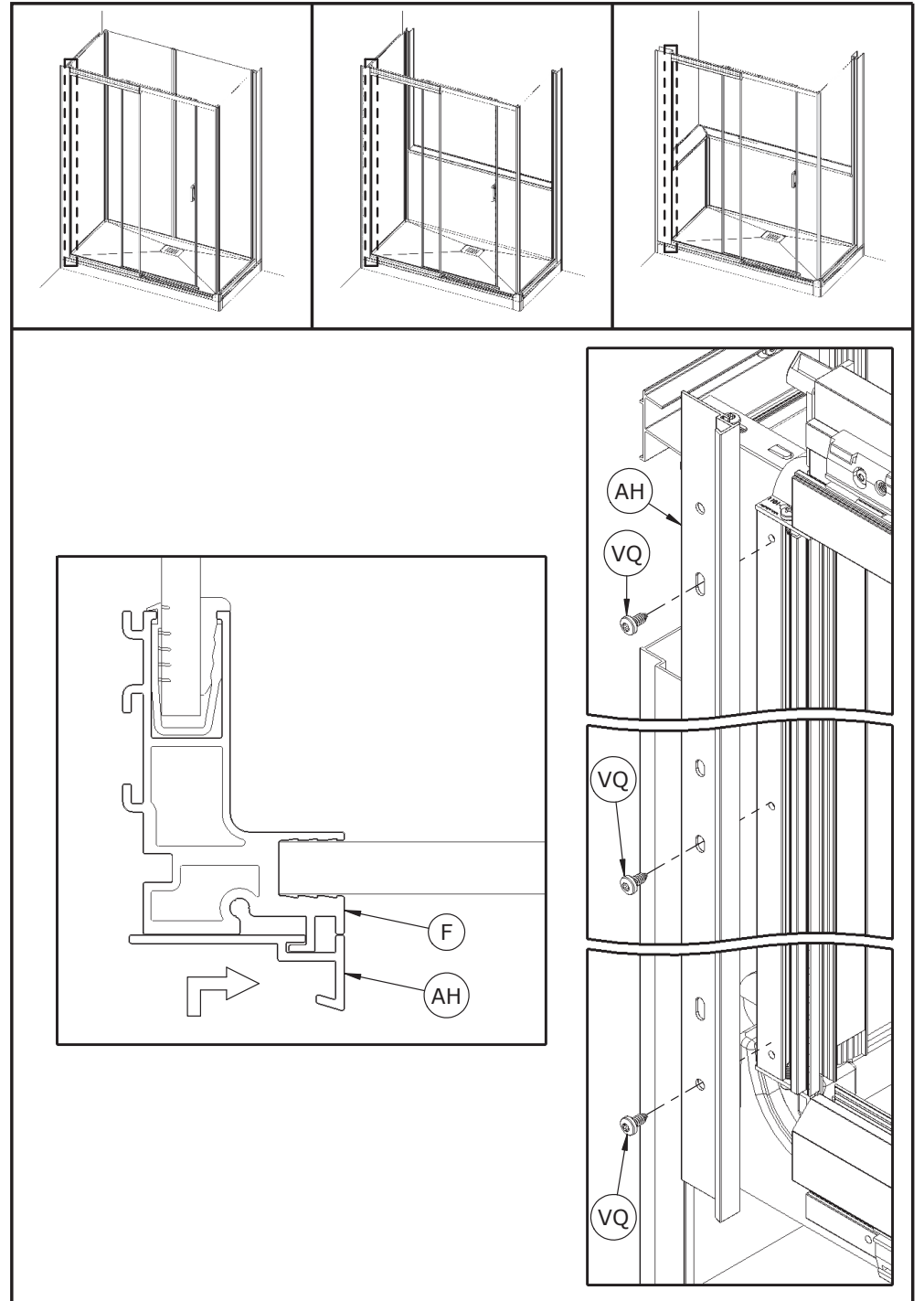
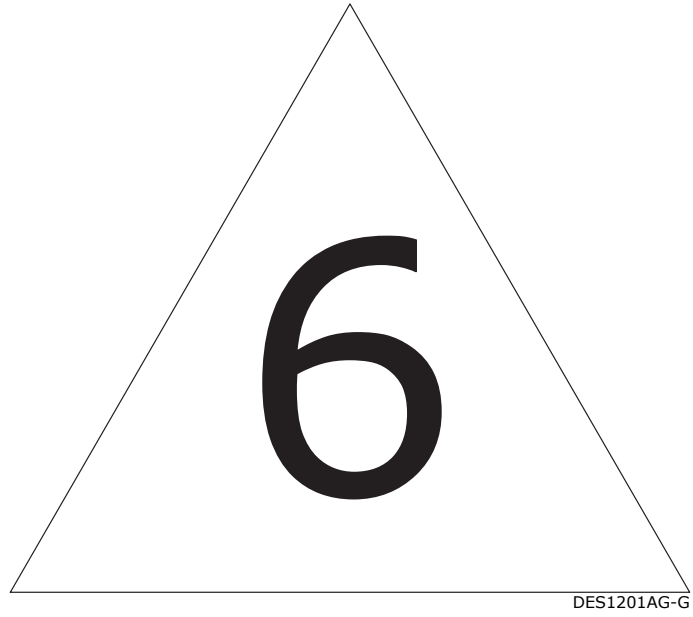

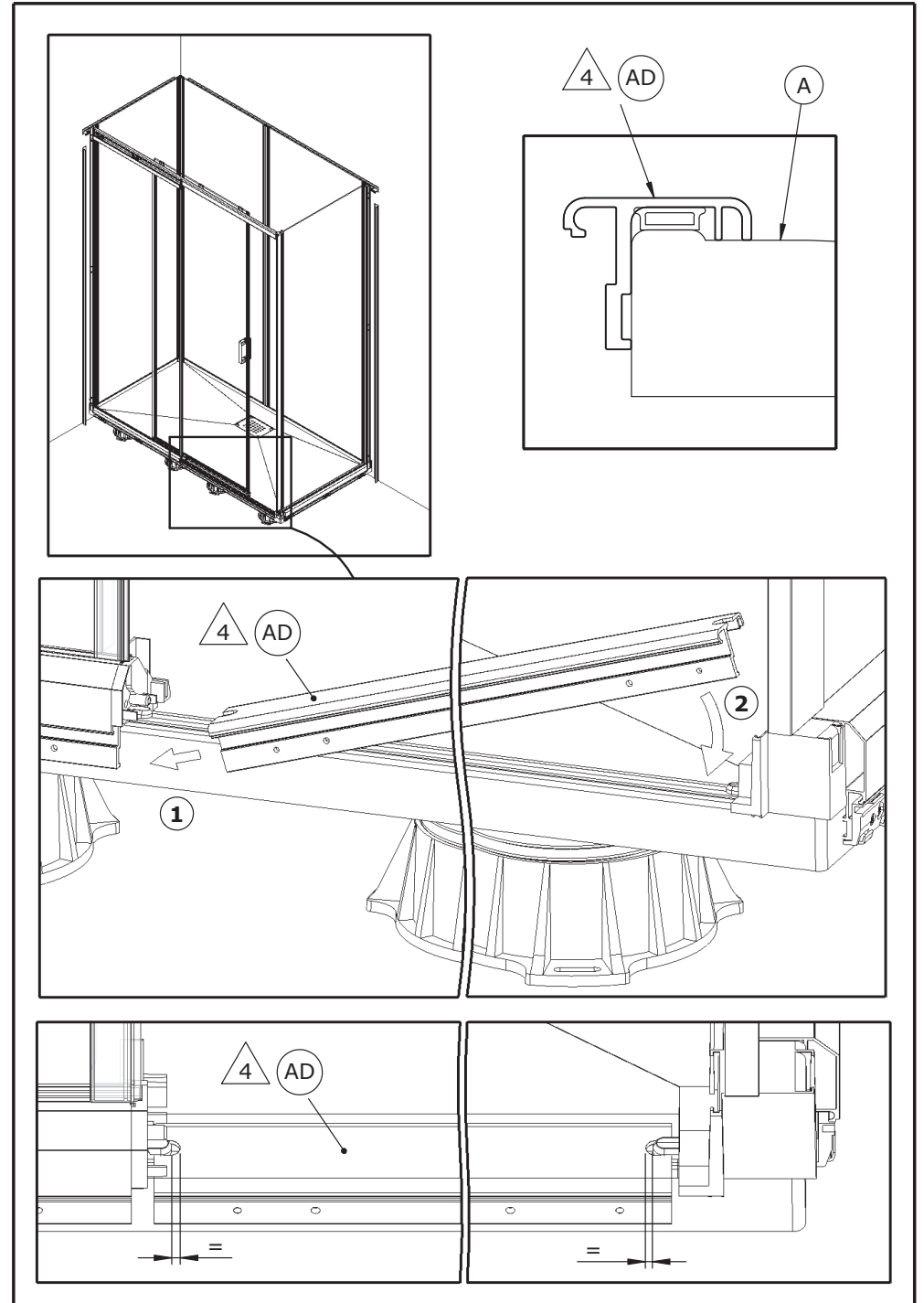
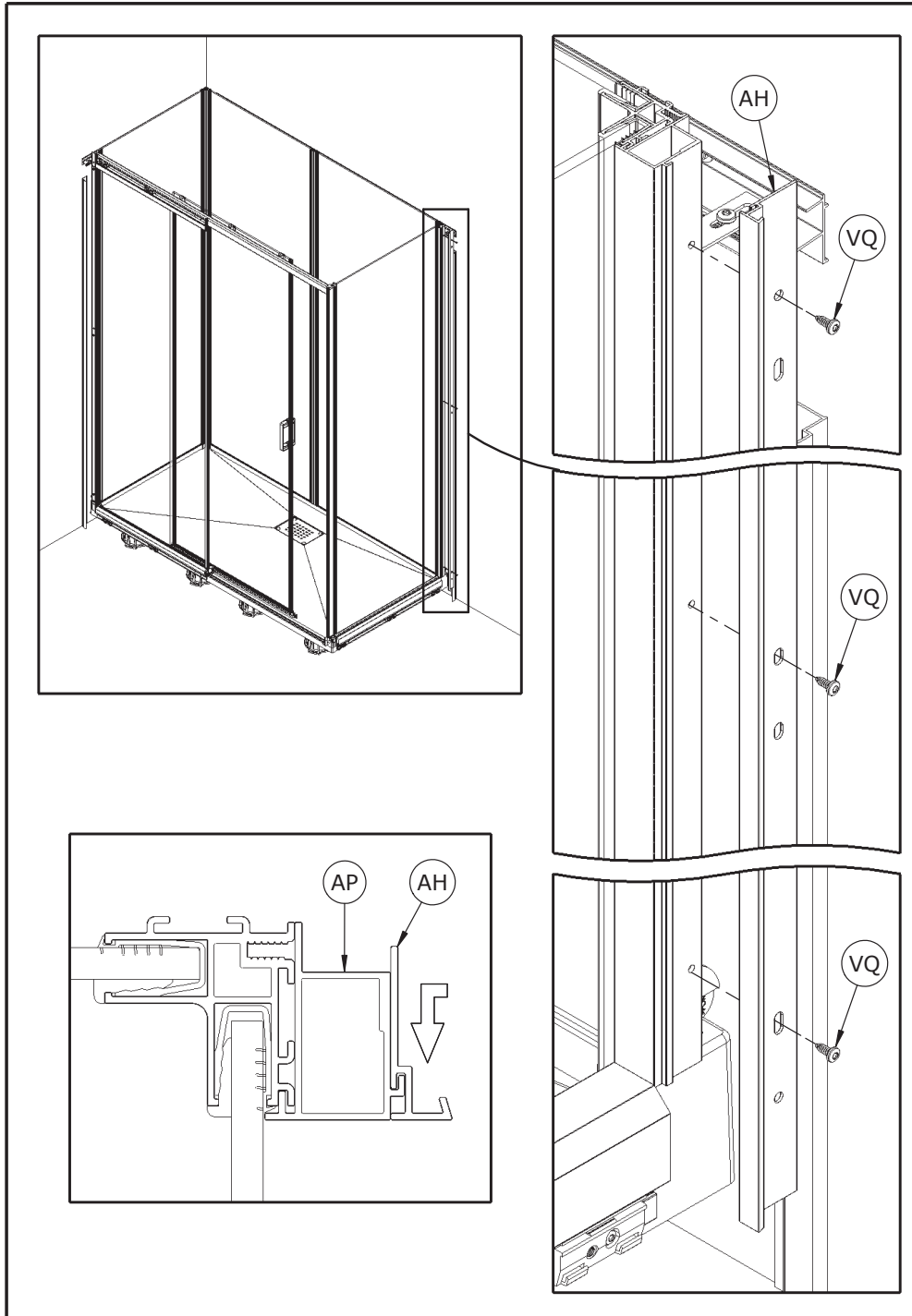

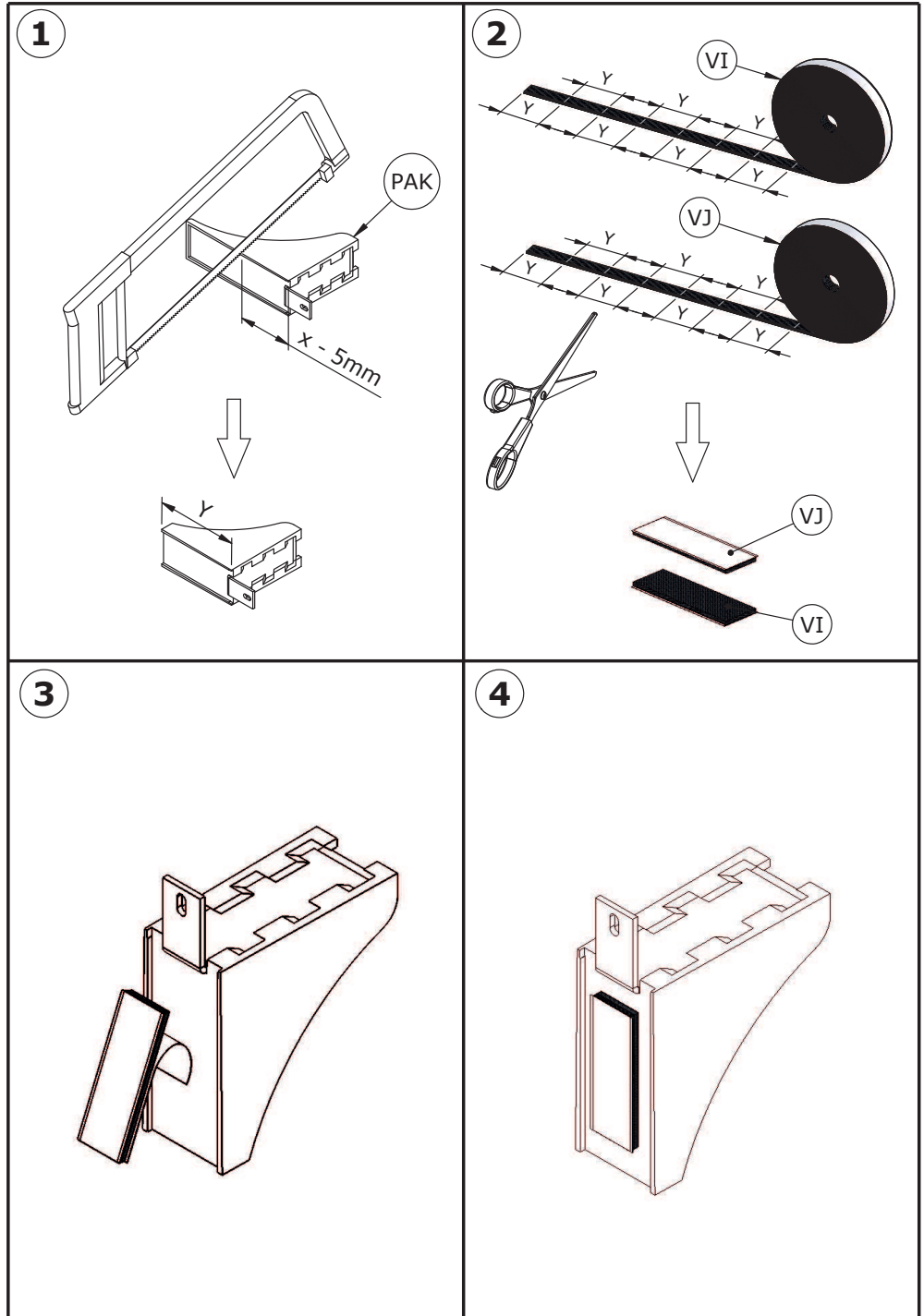
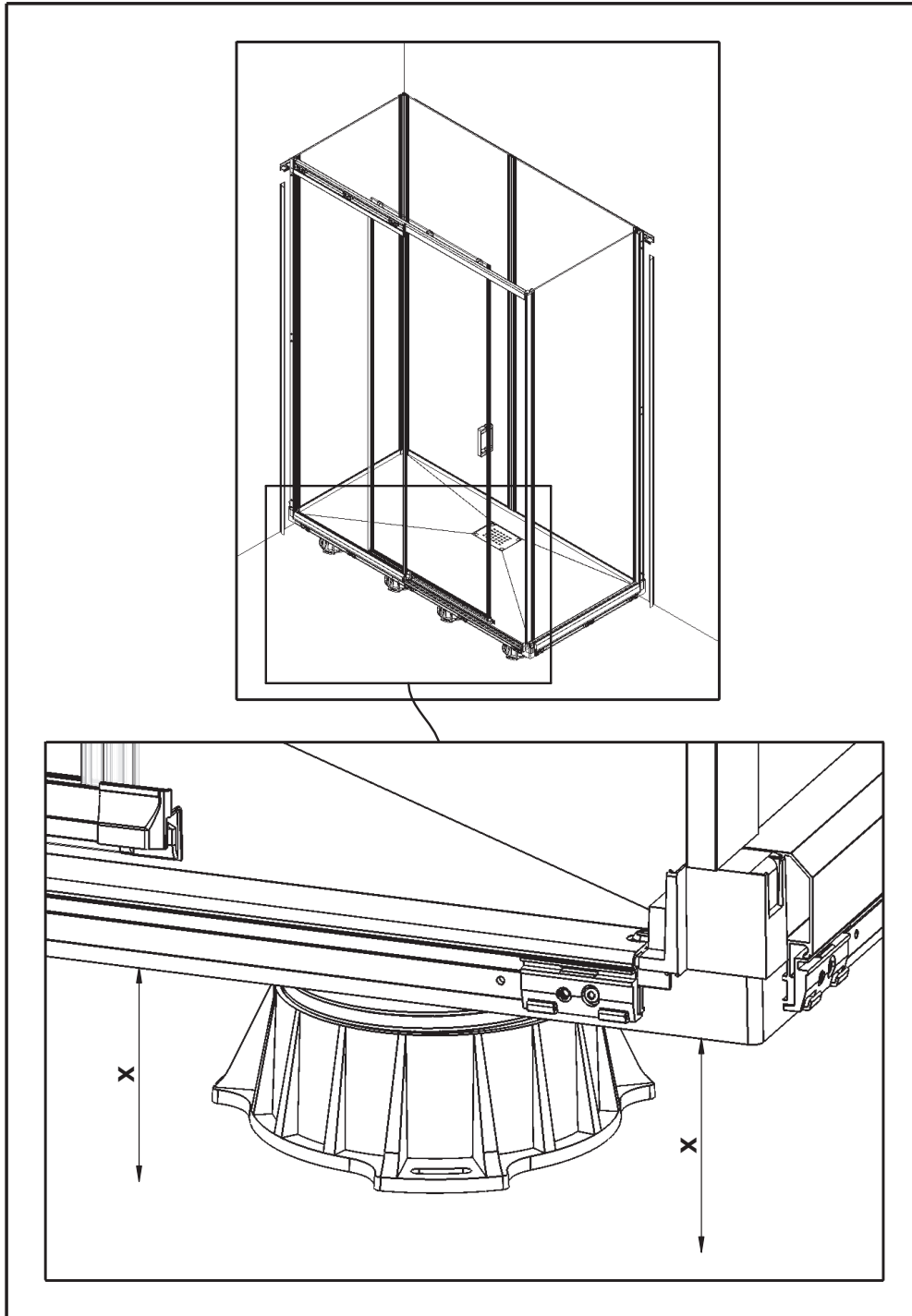

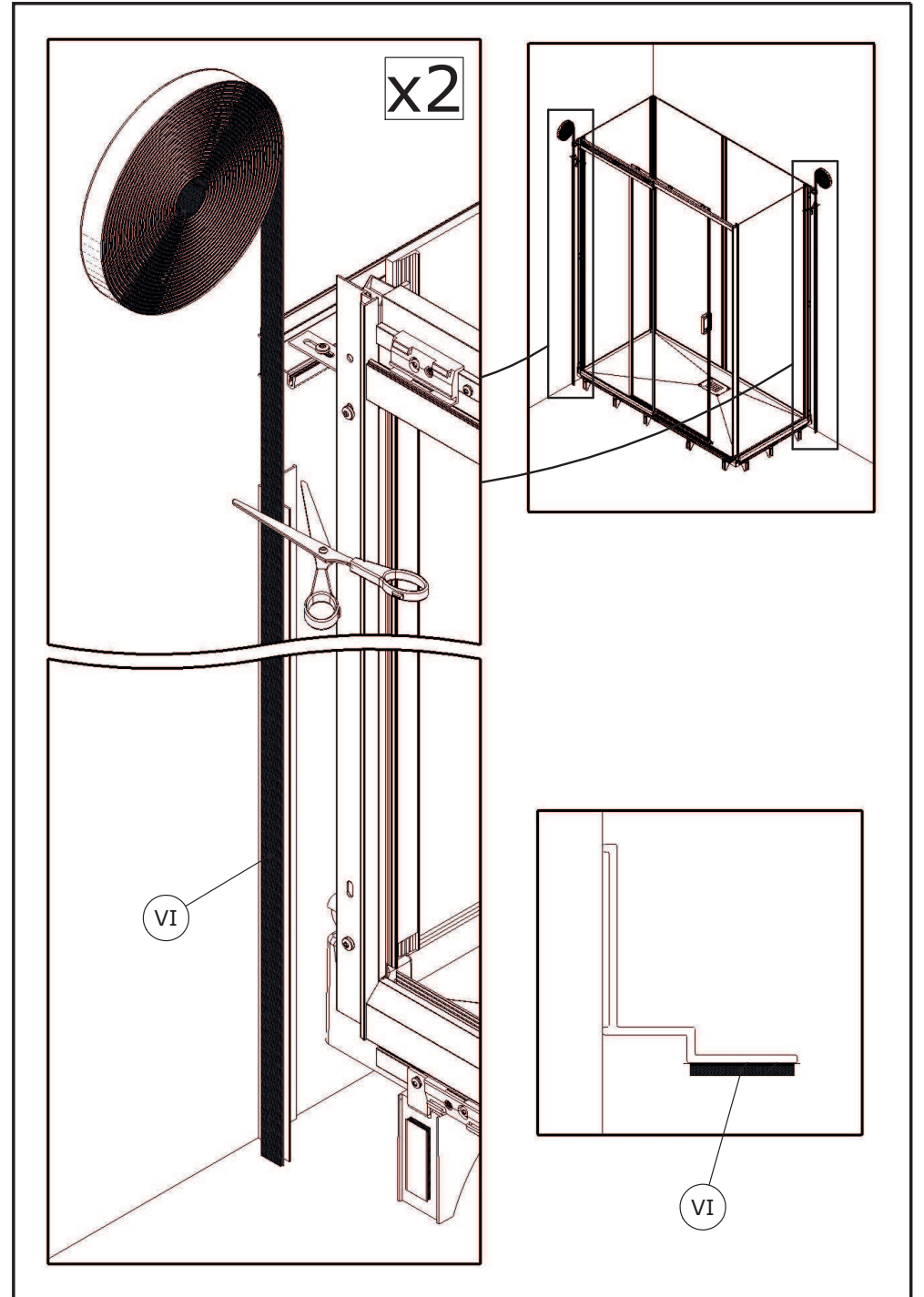
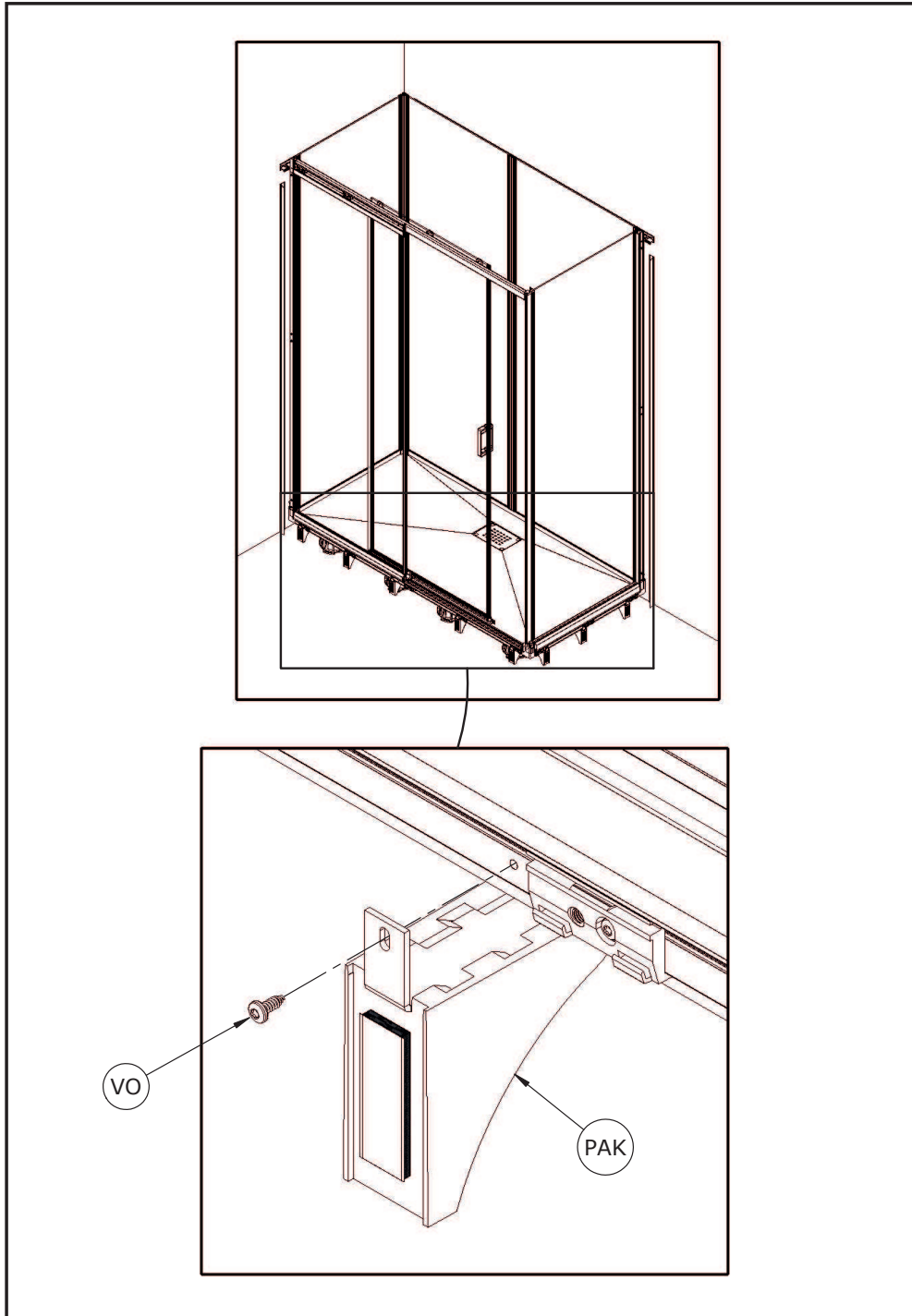

- Retirer l'adhésif
- Remove adhesive
- Quitar el adhesivo
- Rimuovere il adesivo
- Lijm verwijderen
- Klebstoff entfernen

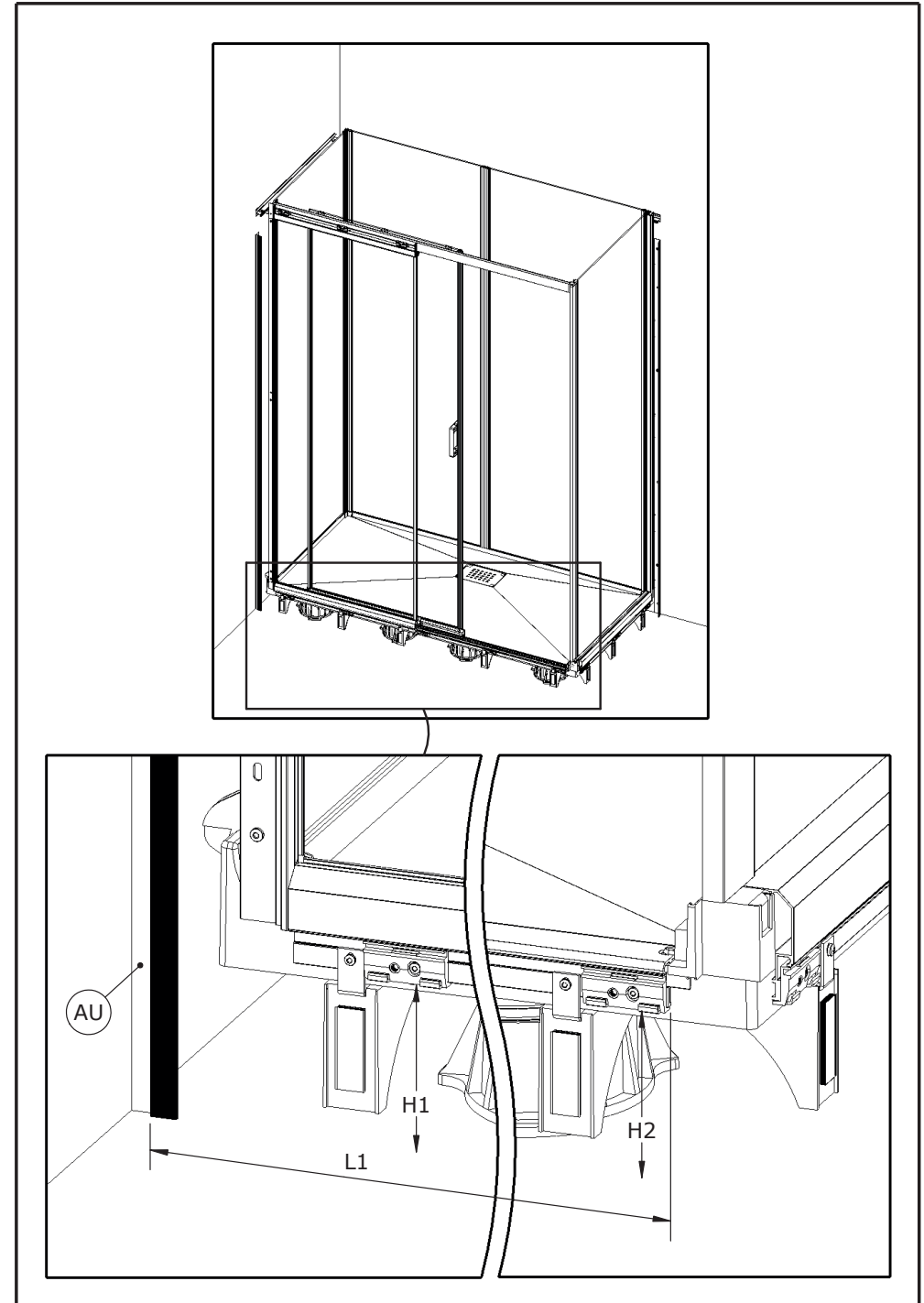
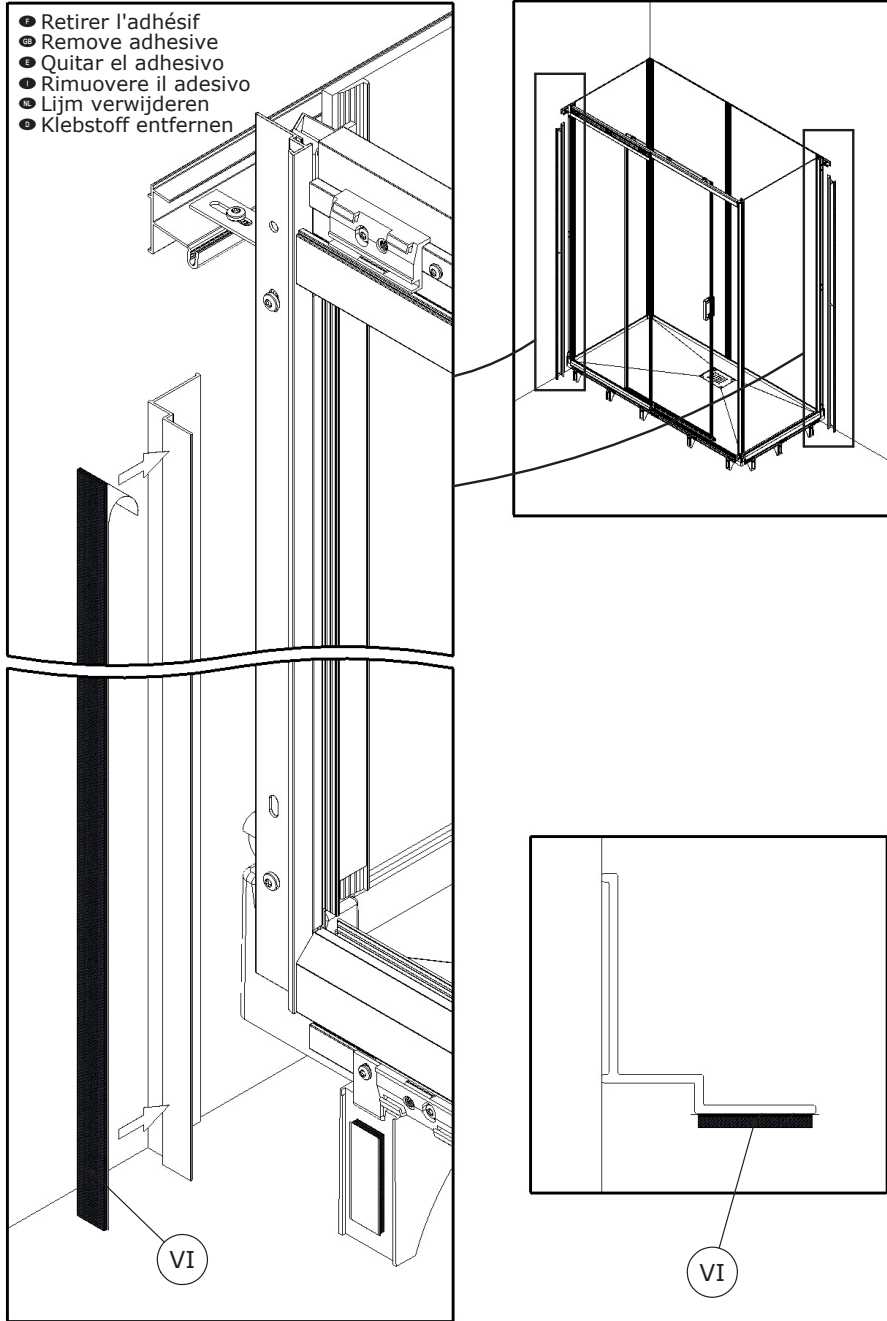

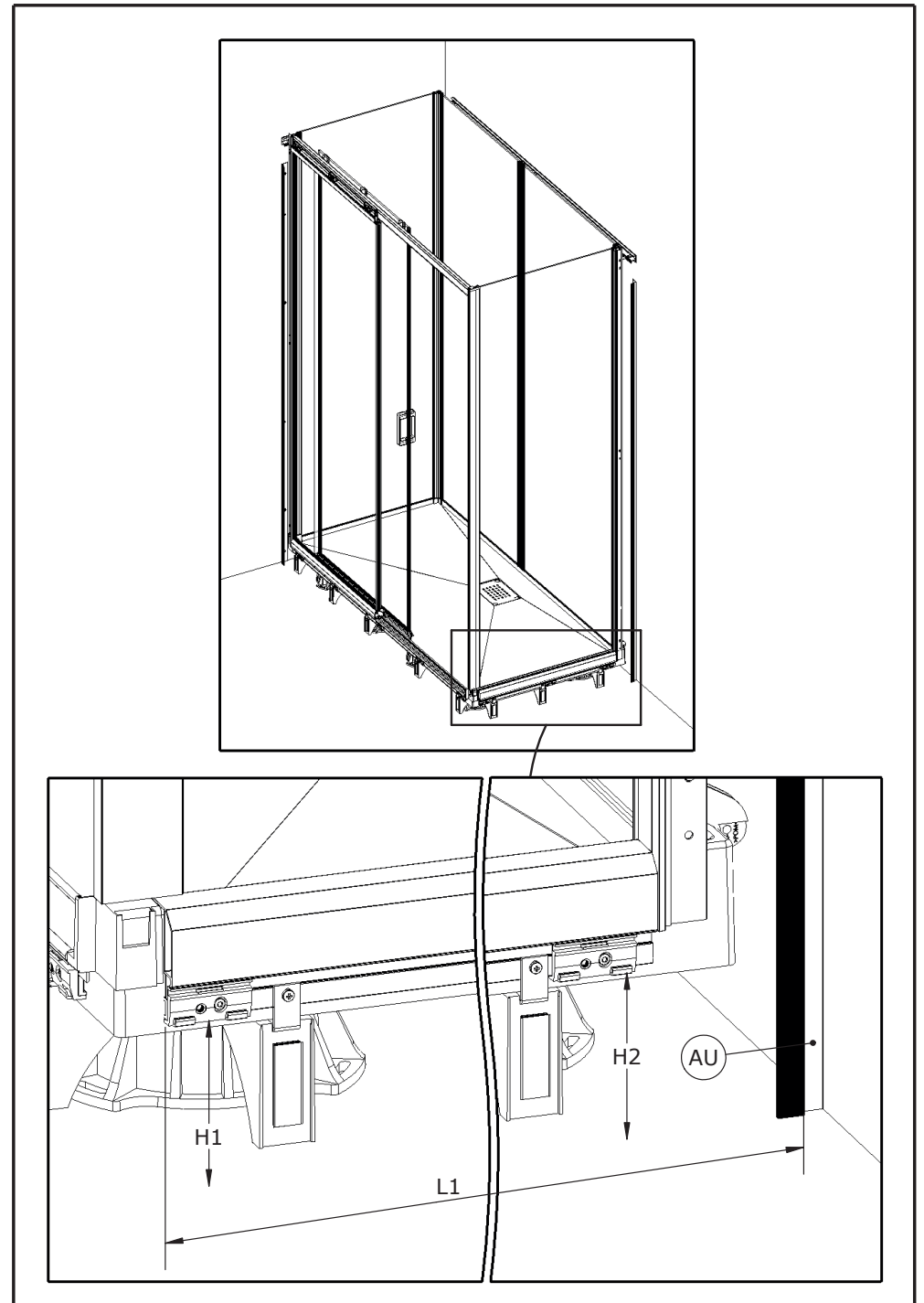
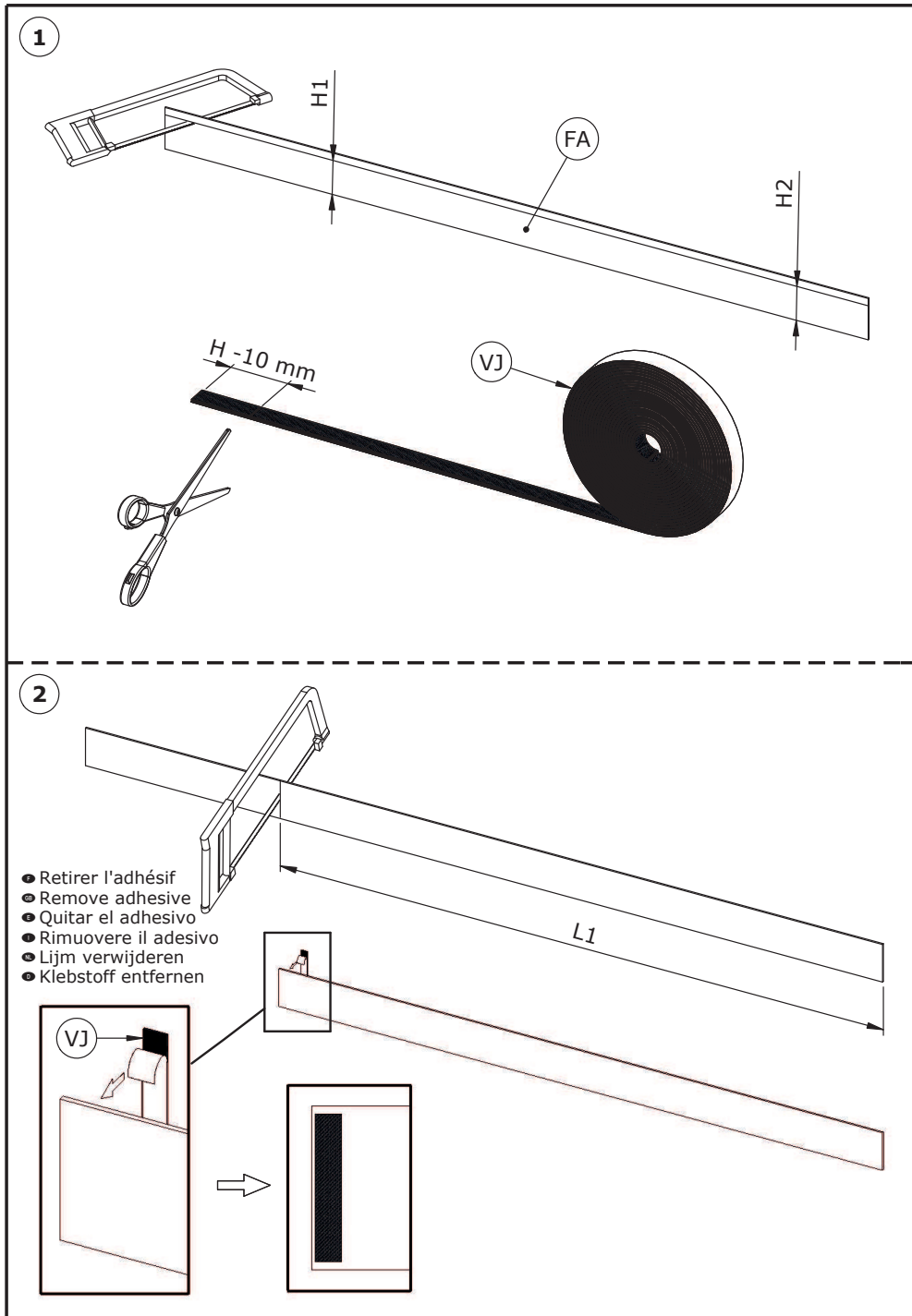

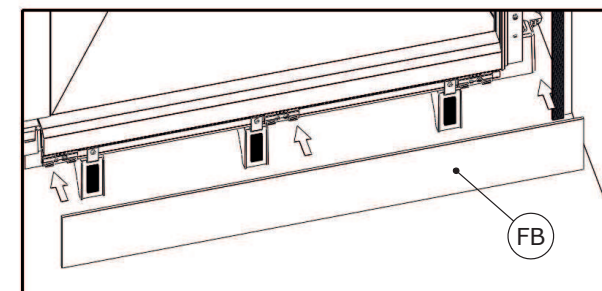
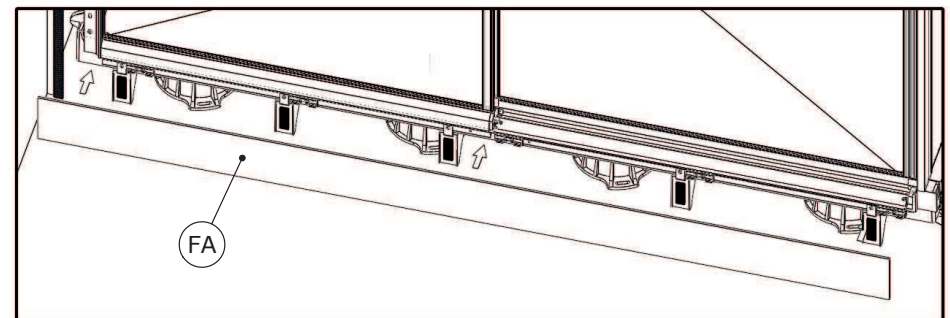
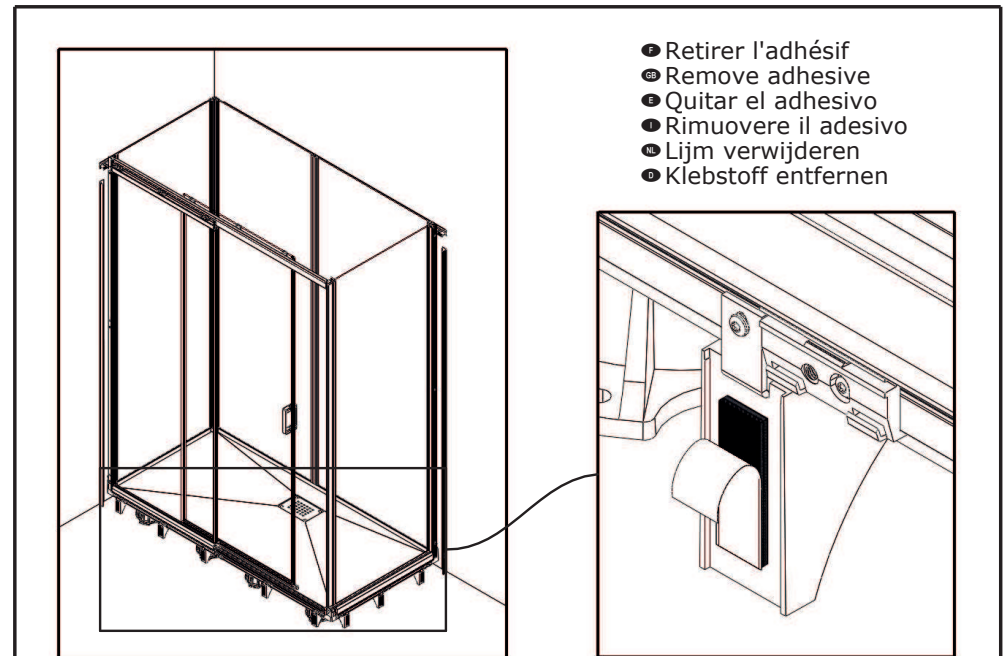
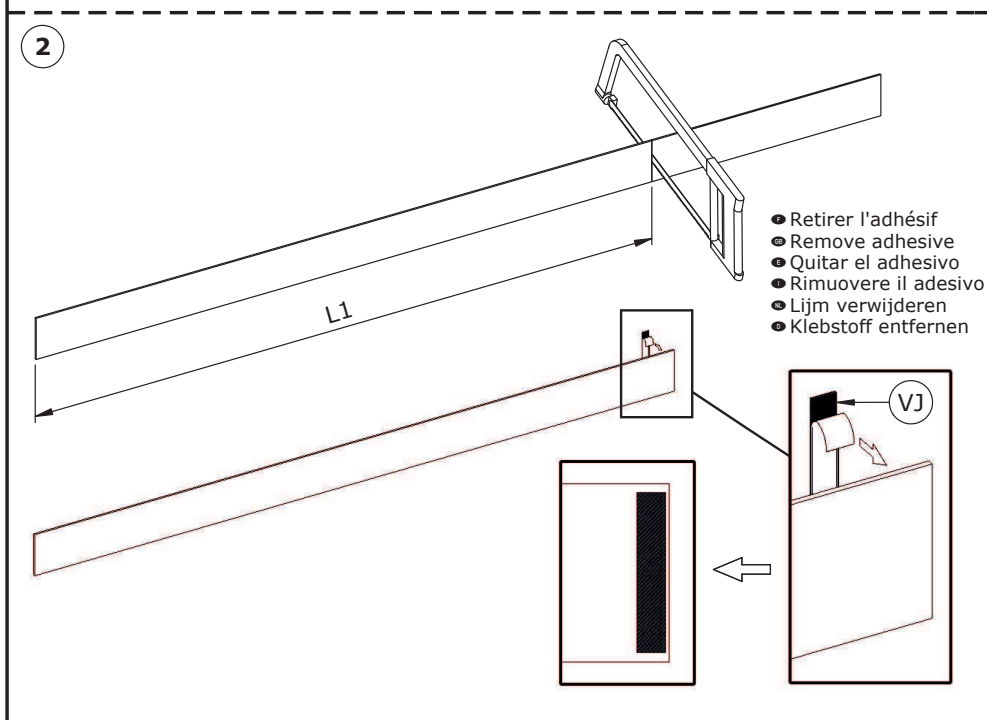
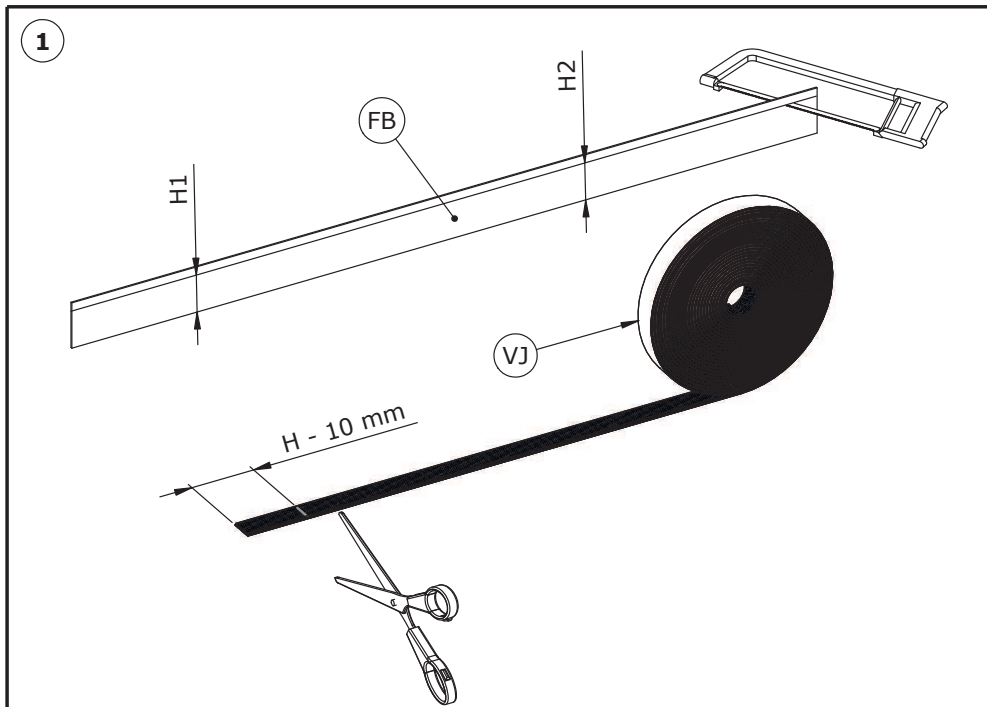

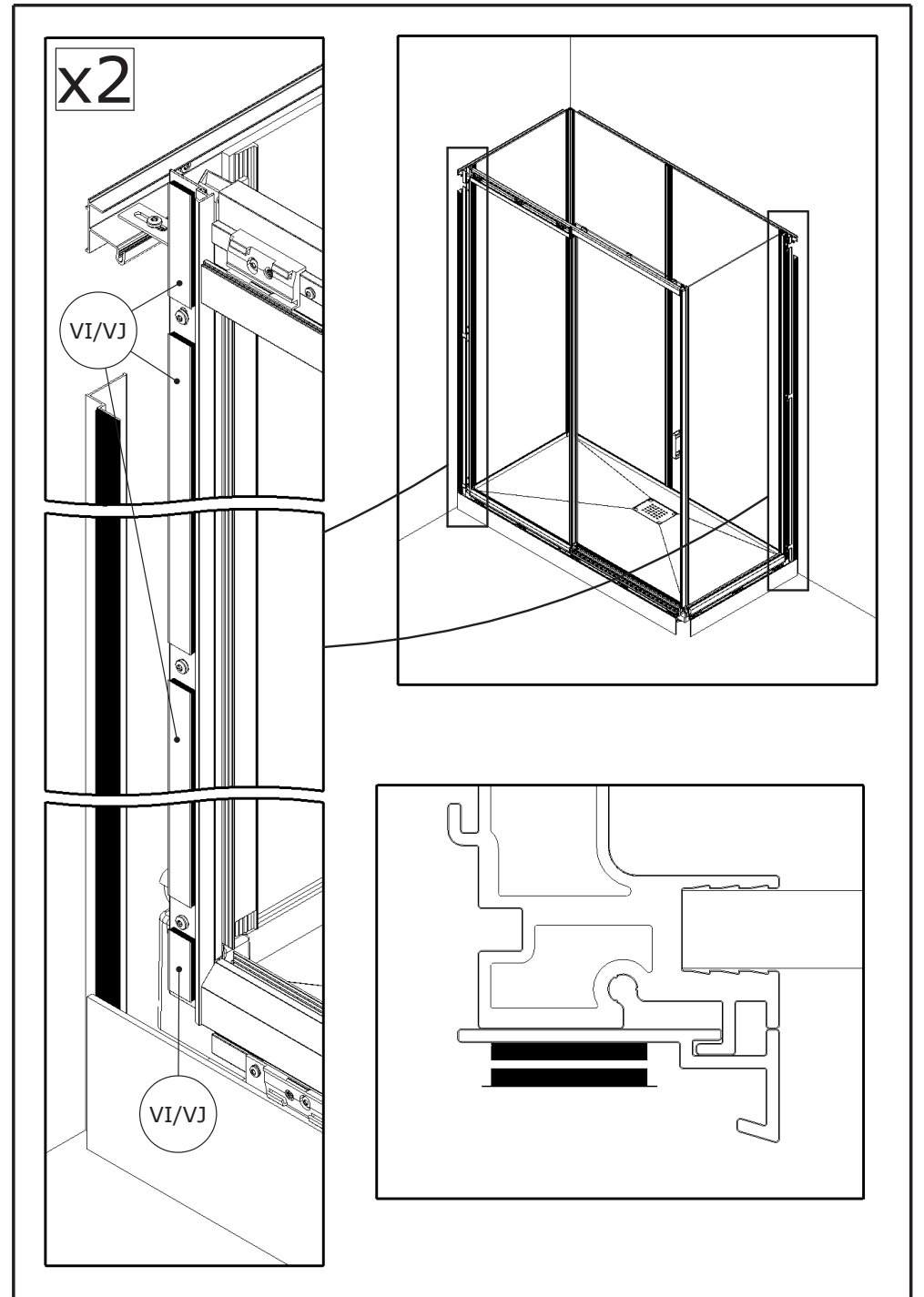
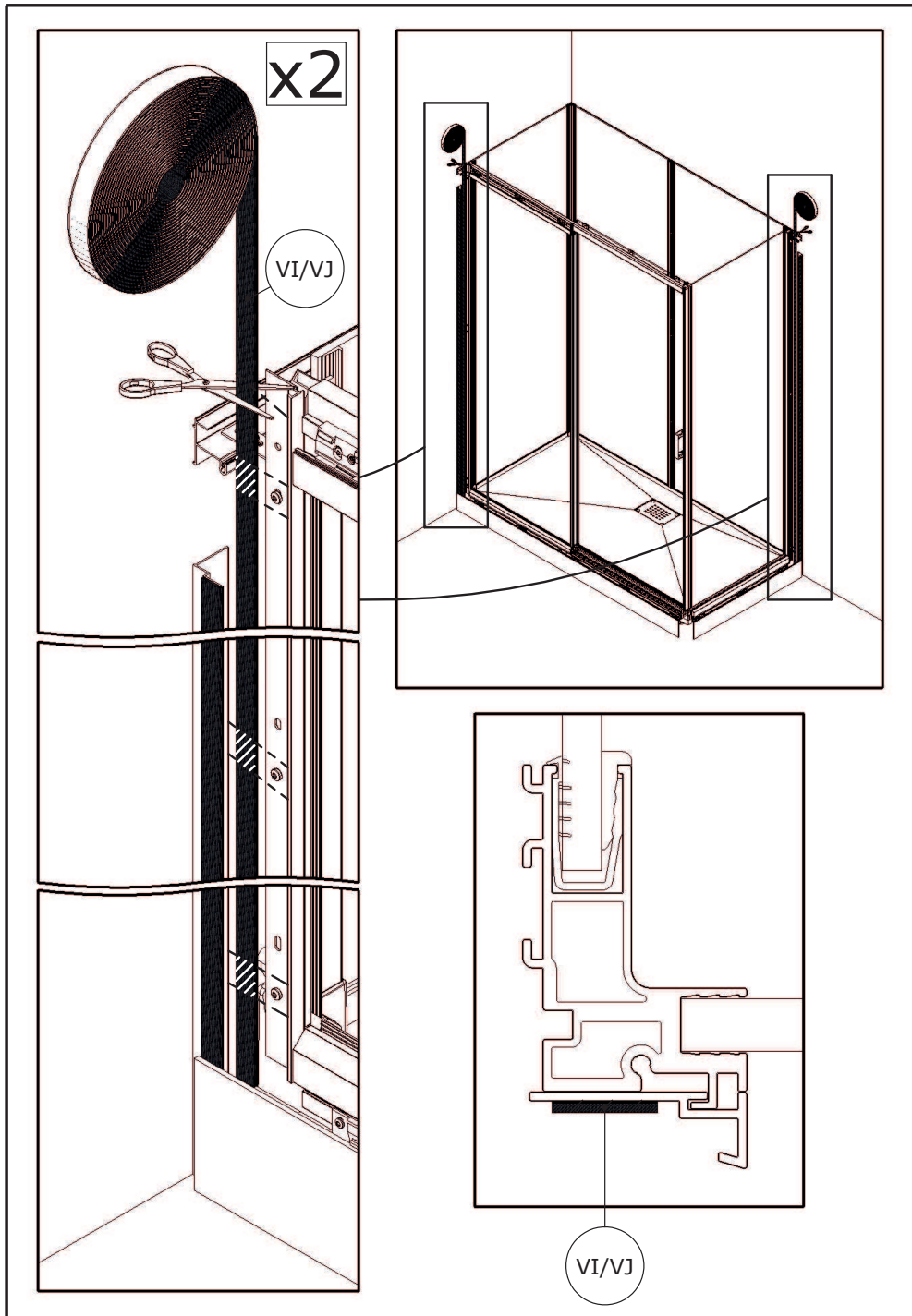

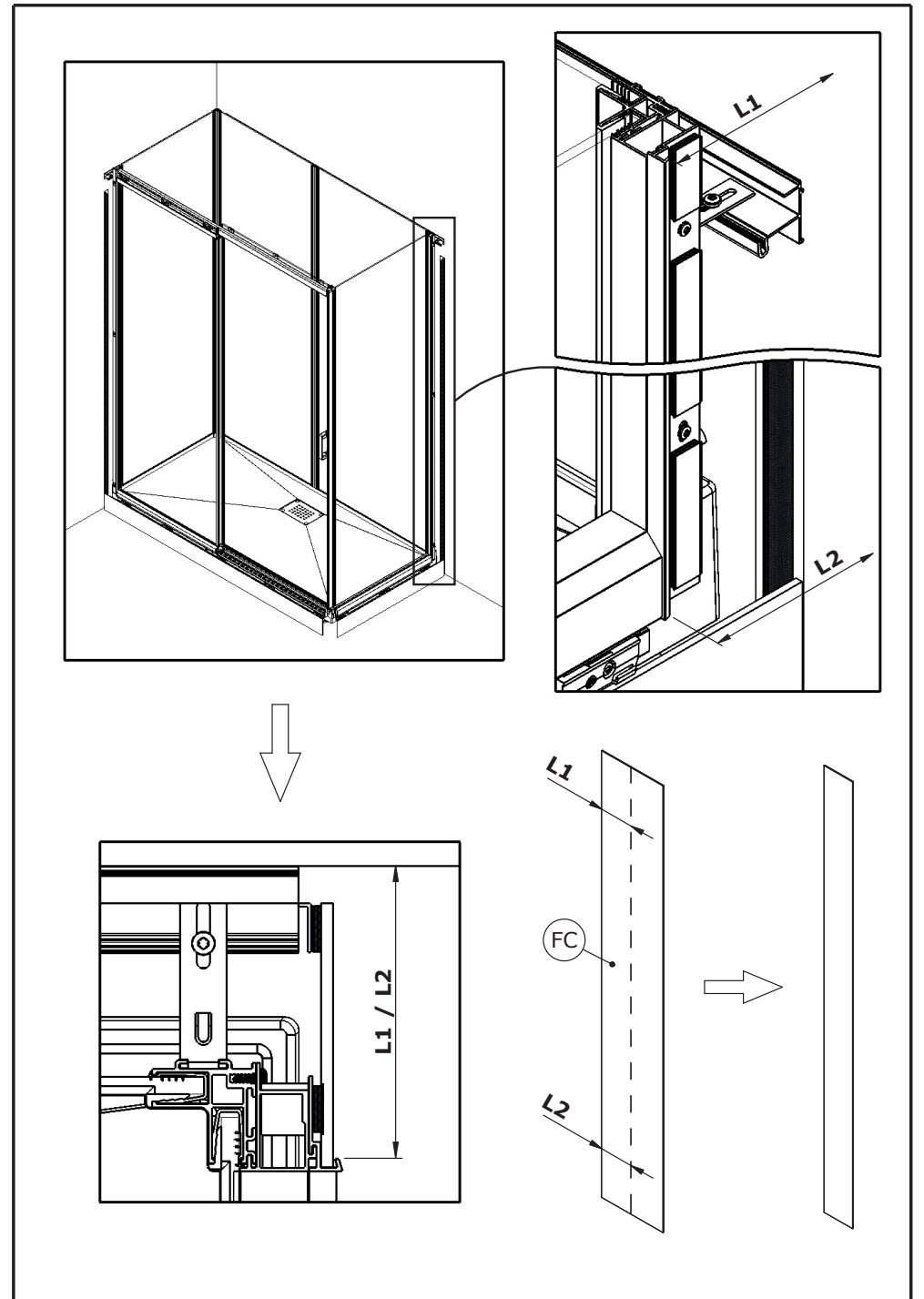
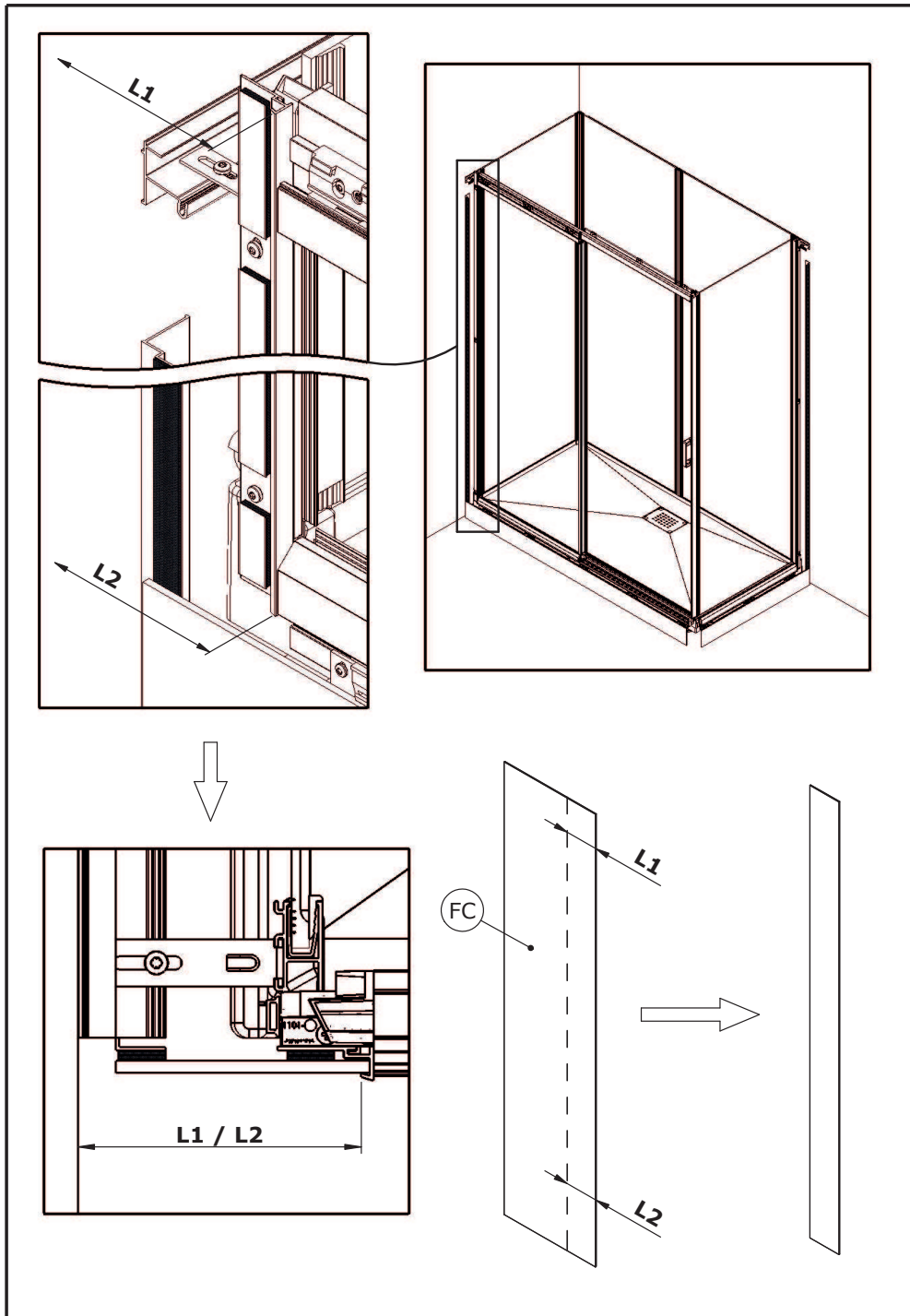

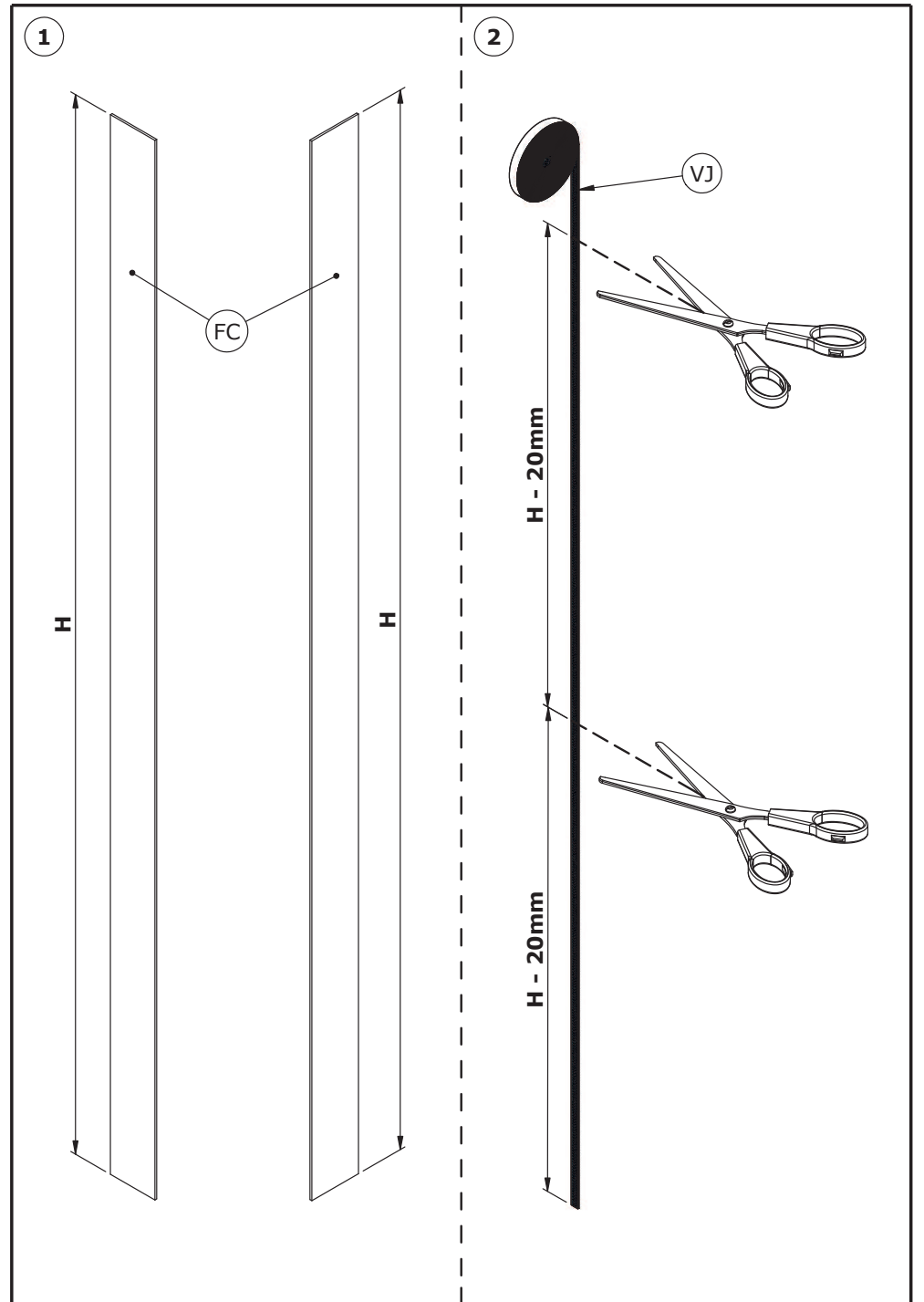
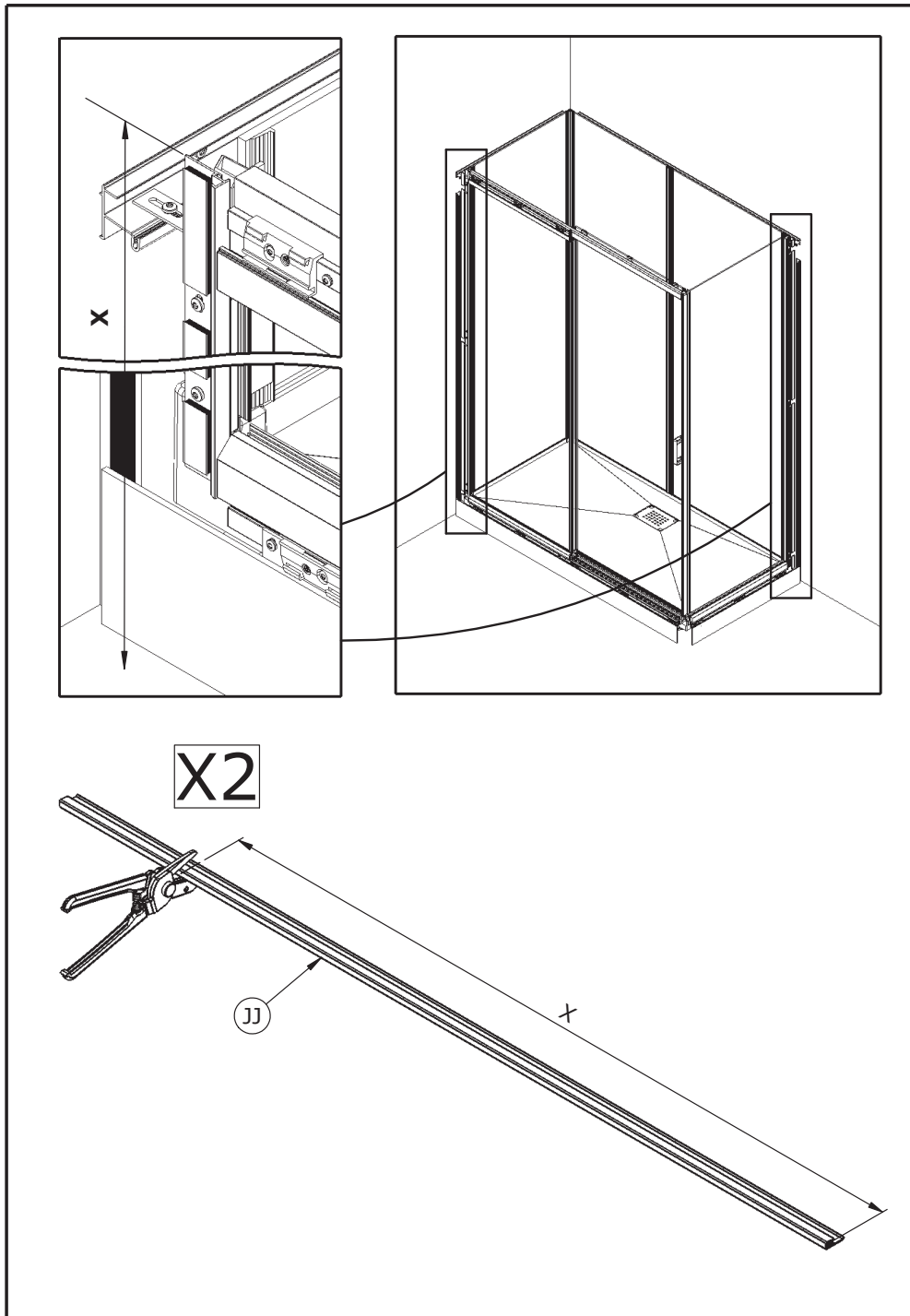

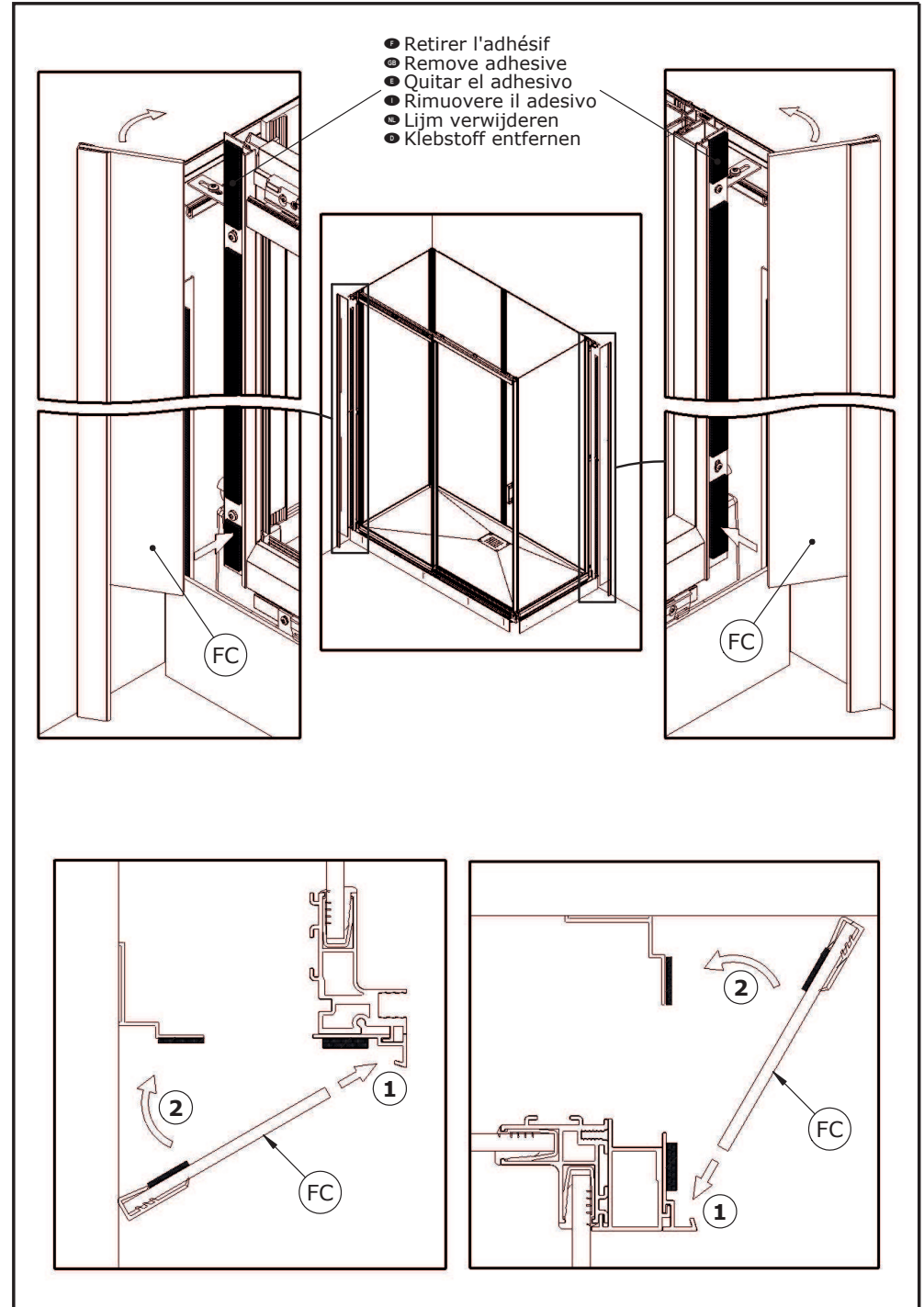
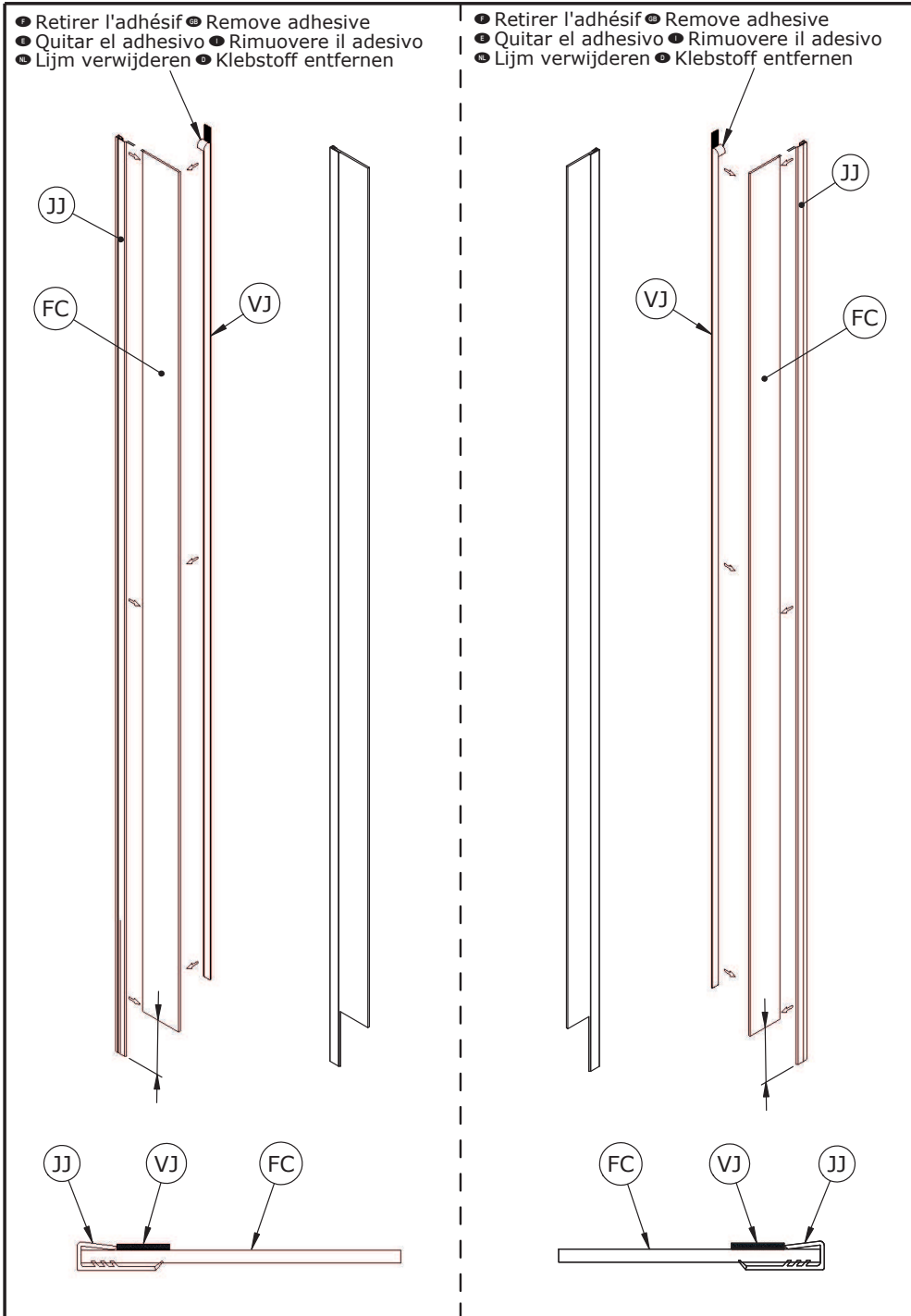

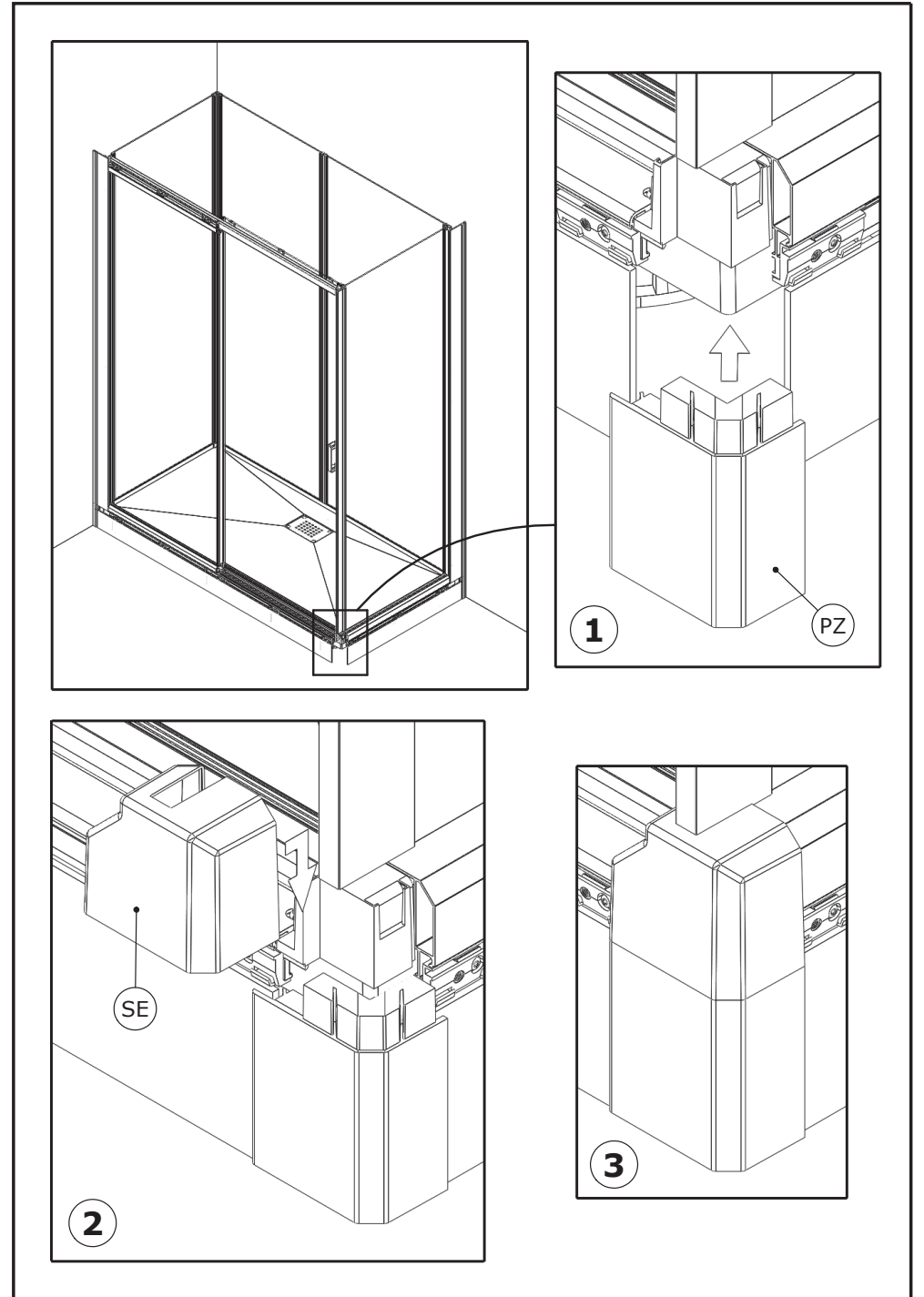
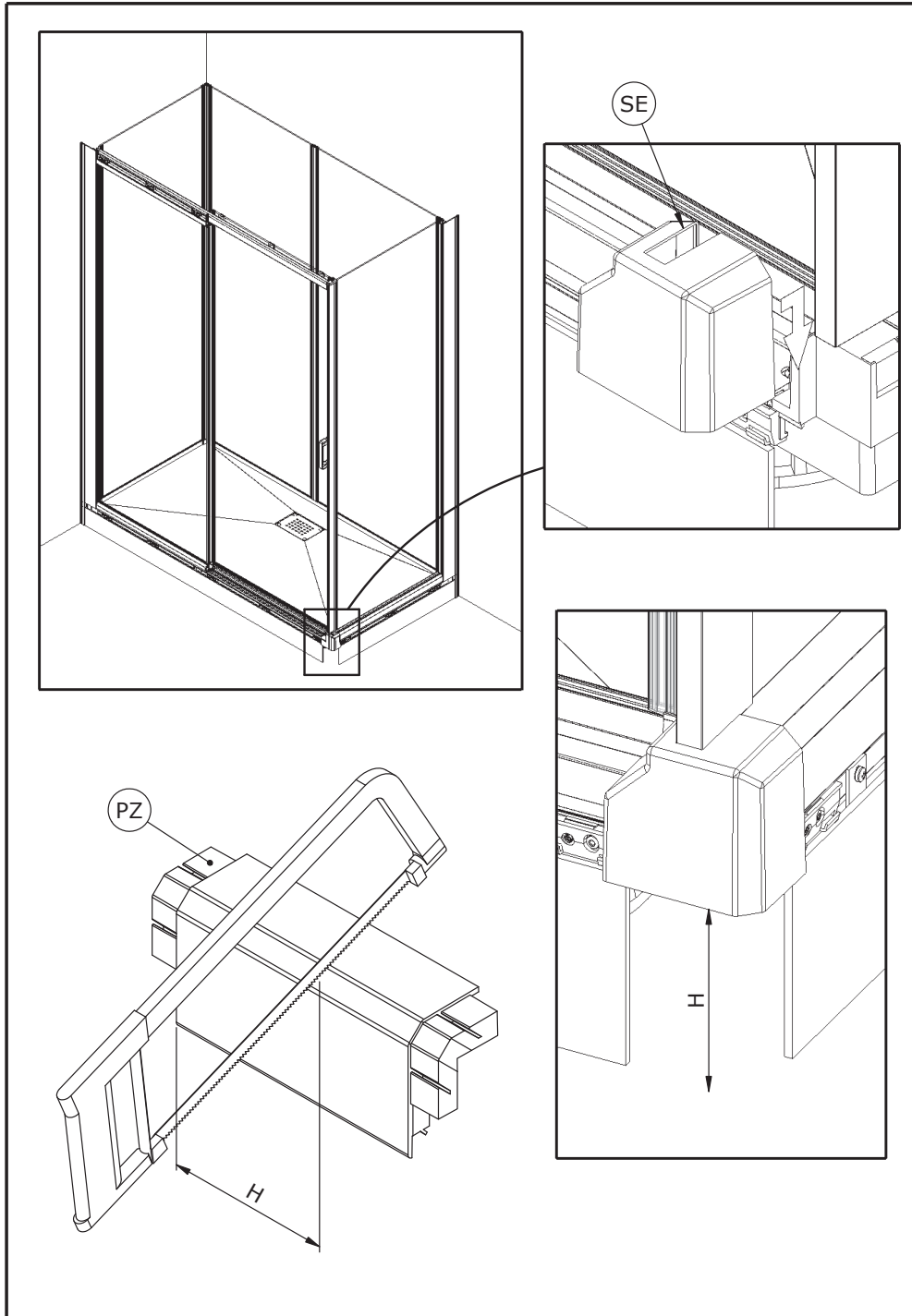

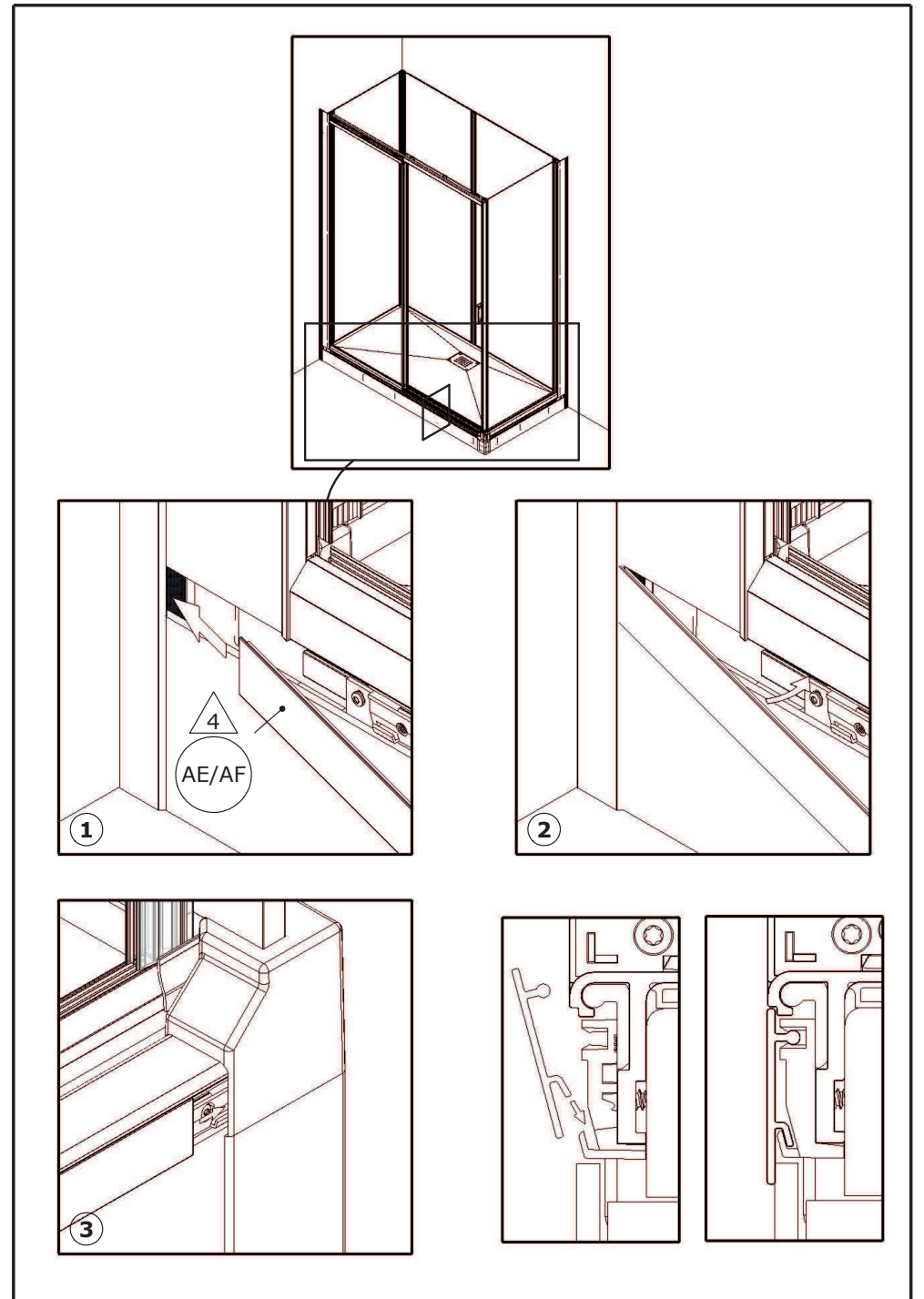
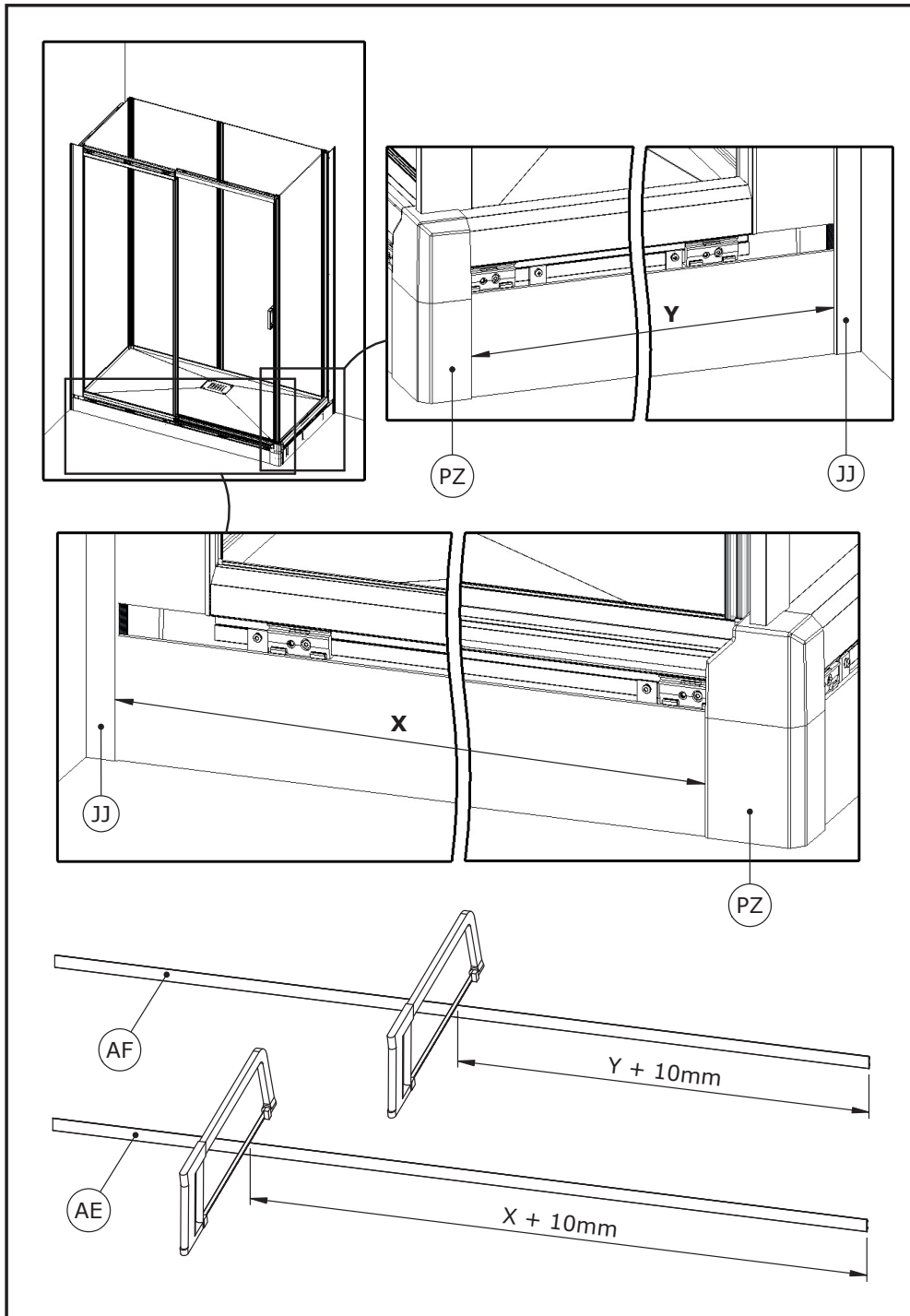

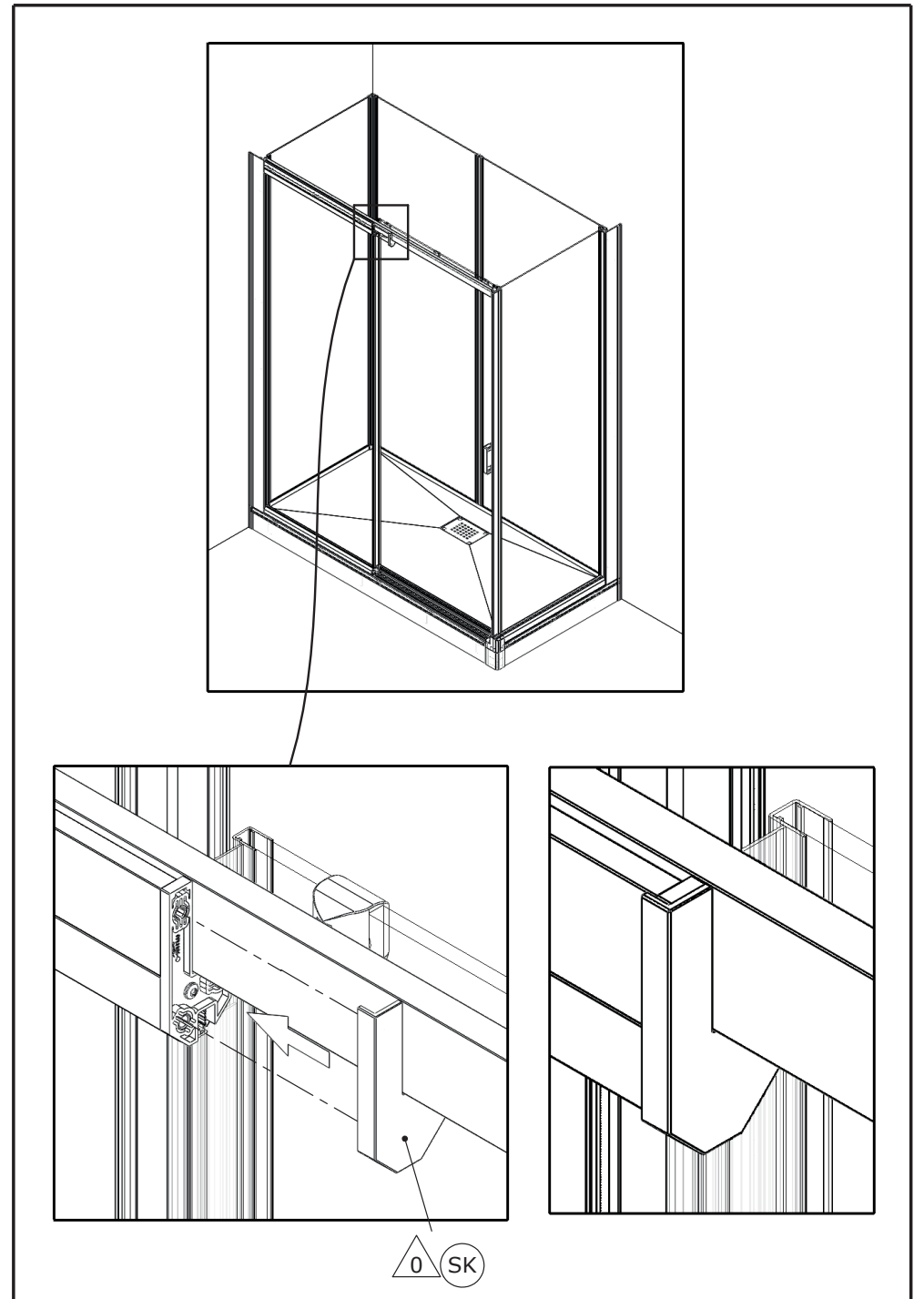
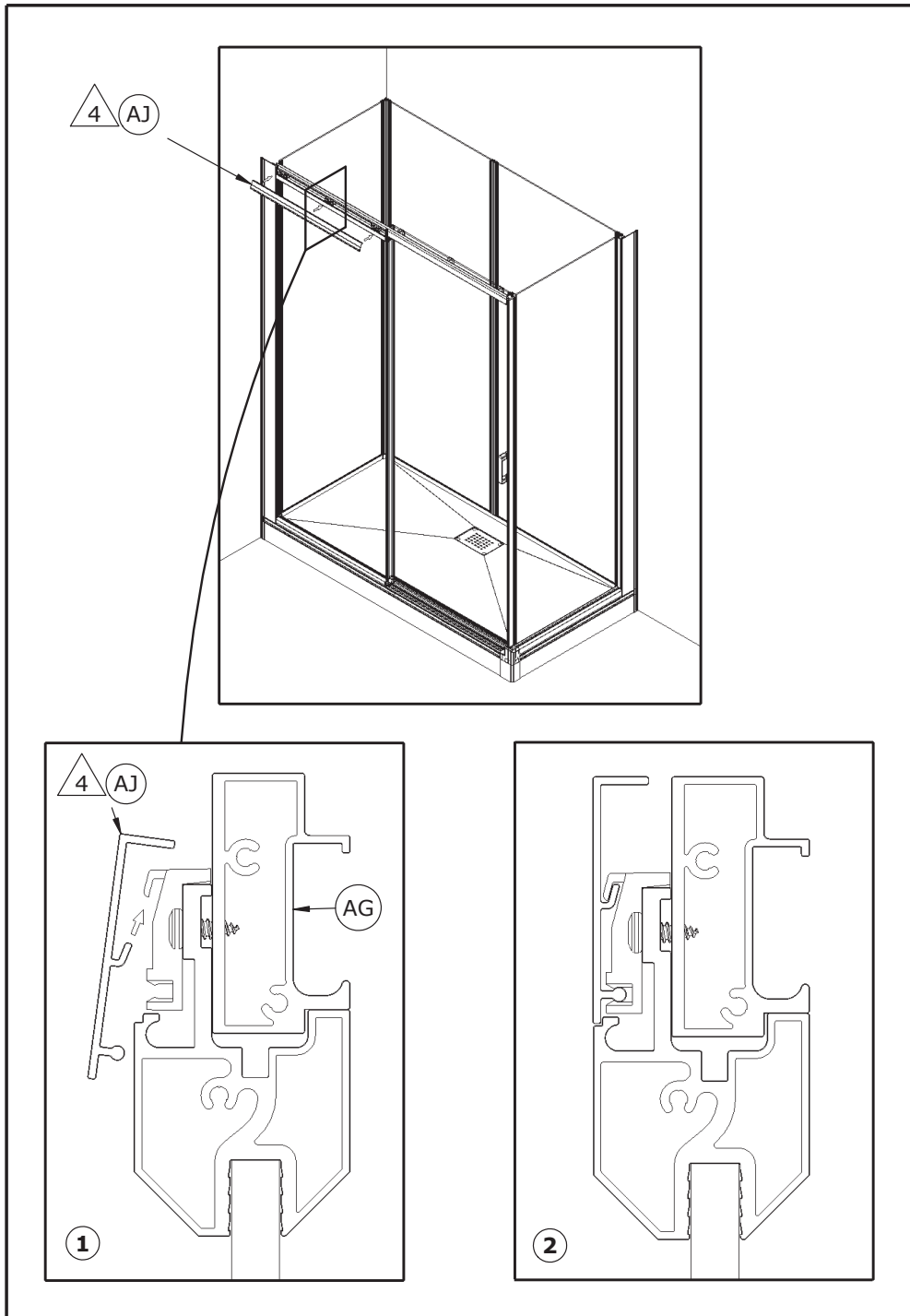

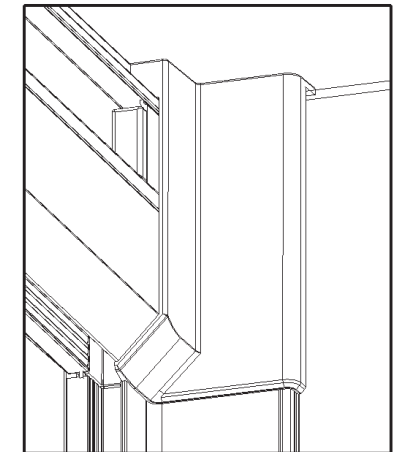
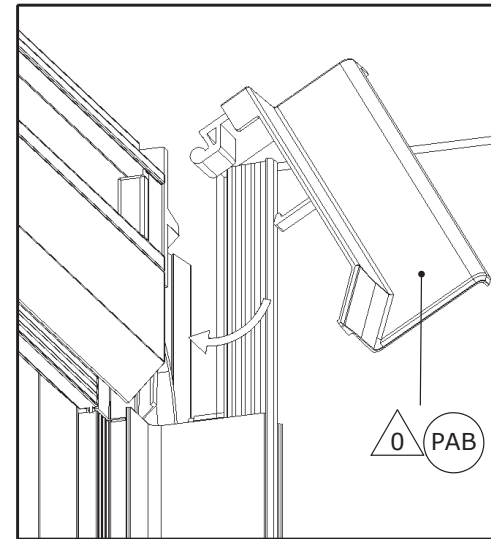
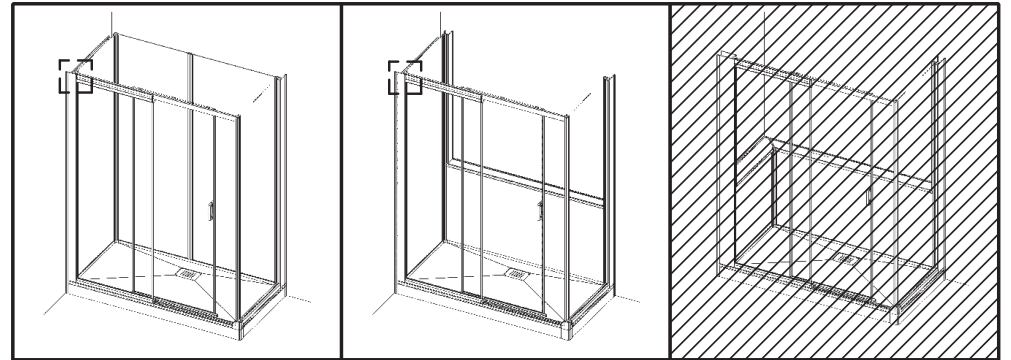
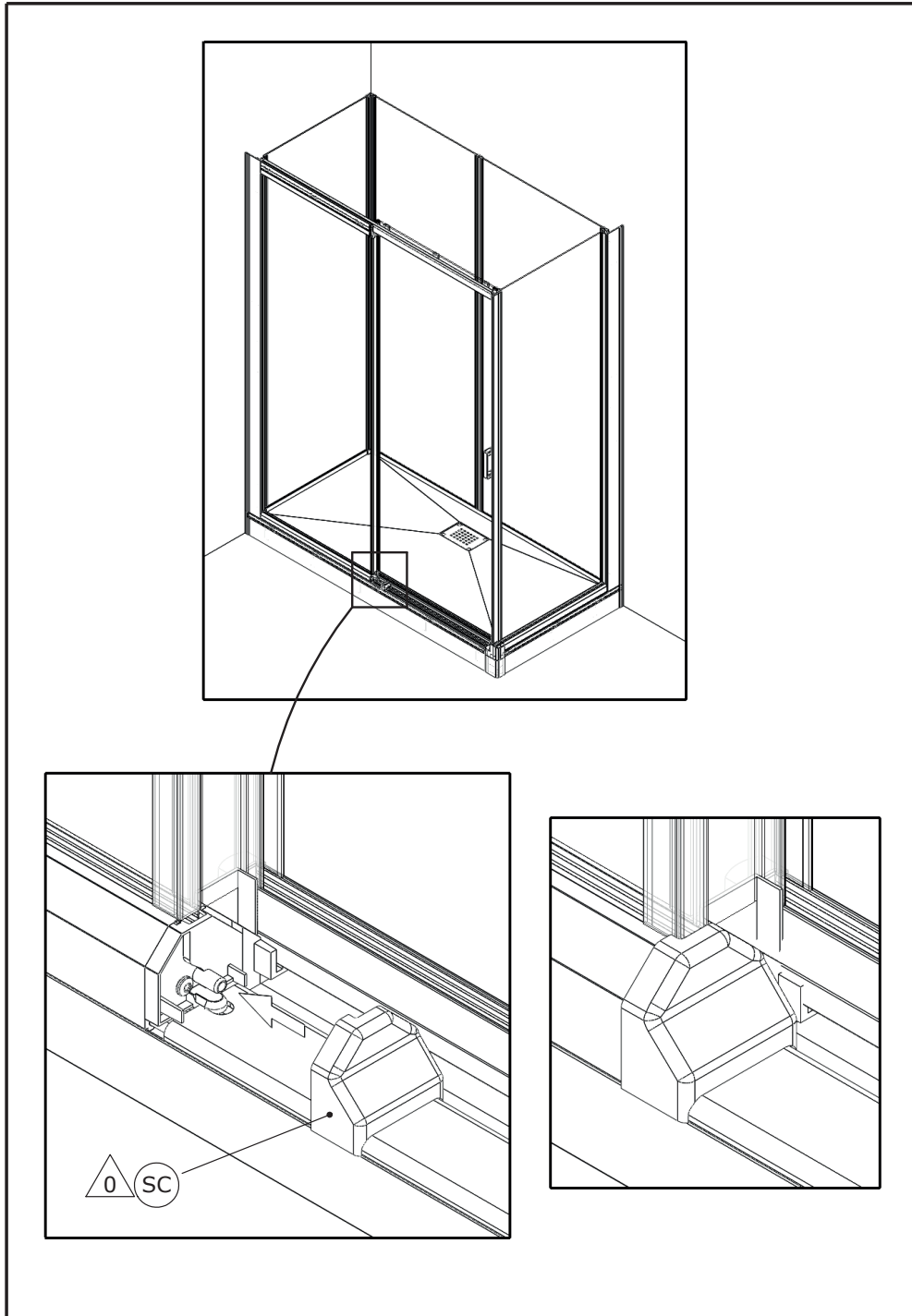

- Intérieur douche ● Inside shower
- Interior ducha ● Doccia interni
- Binnen douche ● Innenraum der Kabine

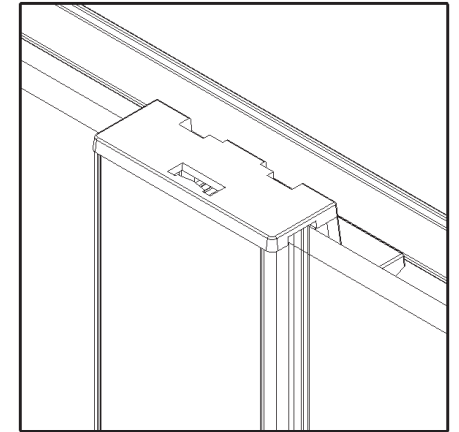
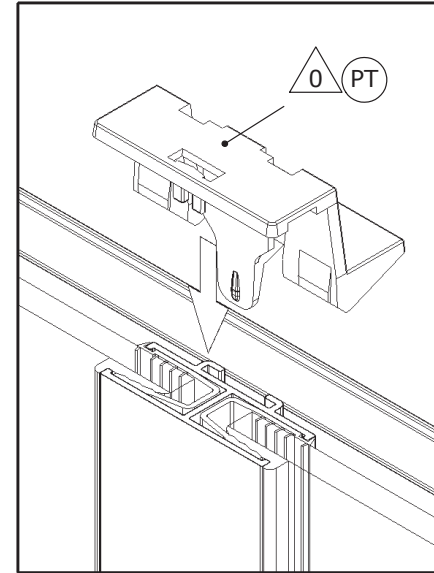
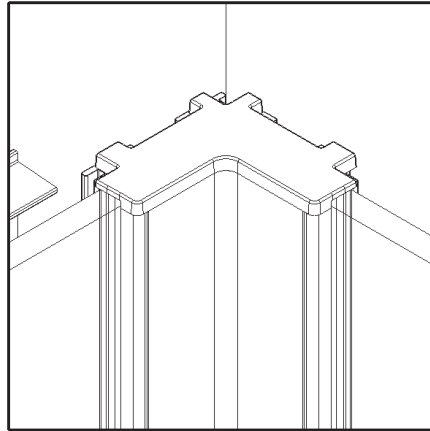
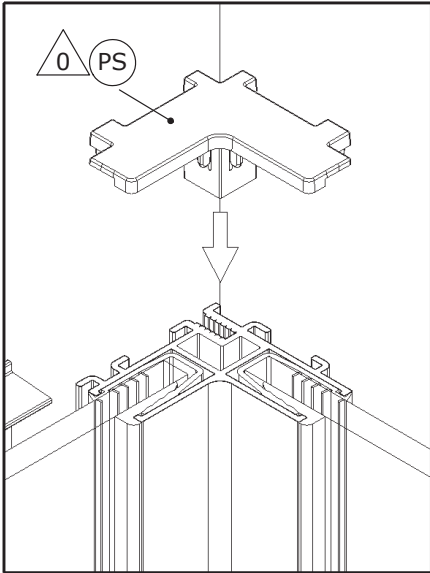
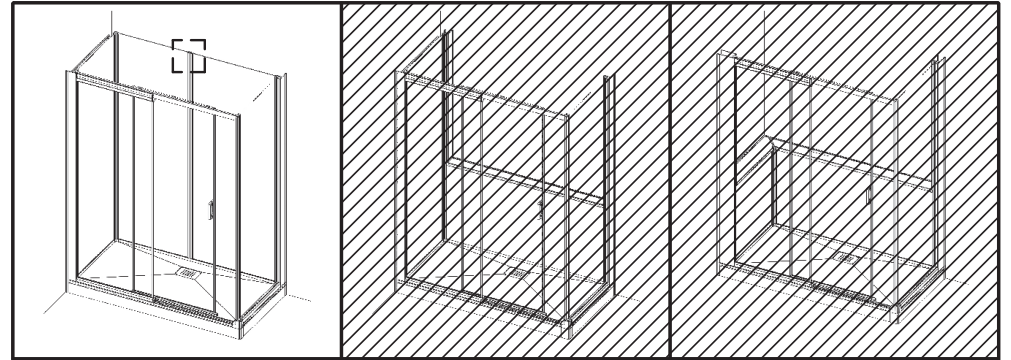
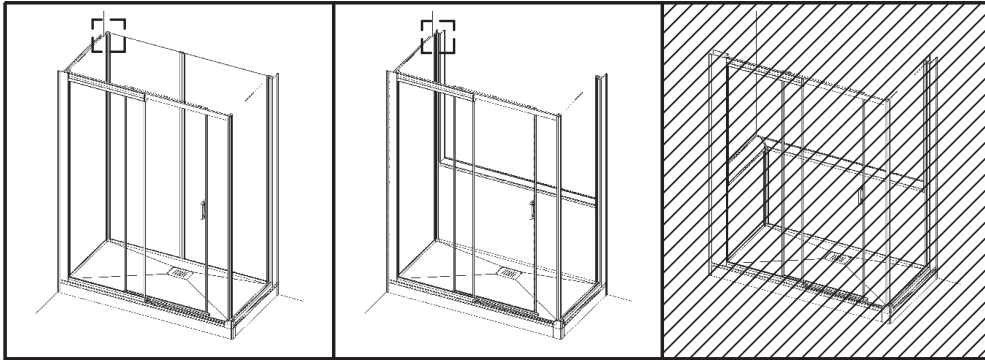

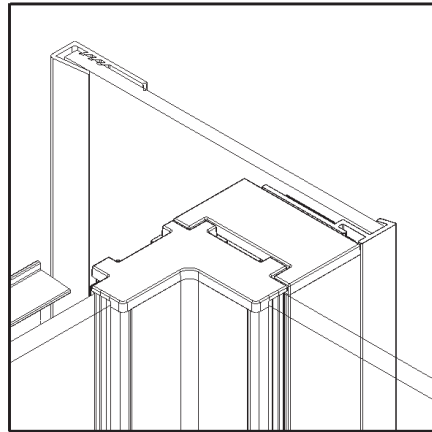
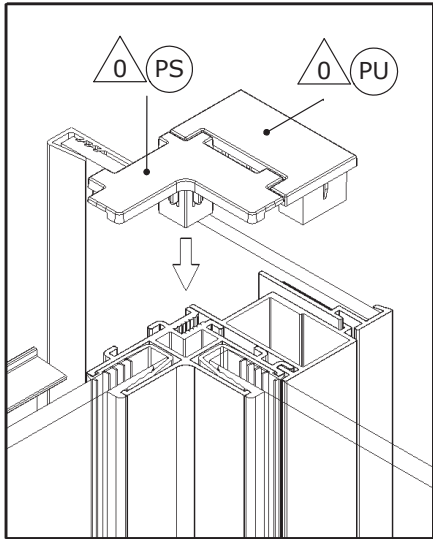
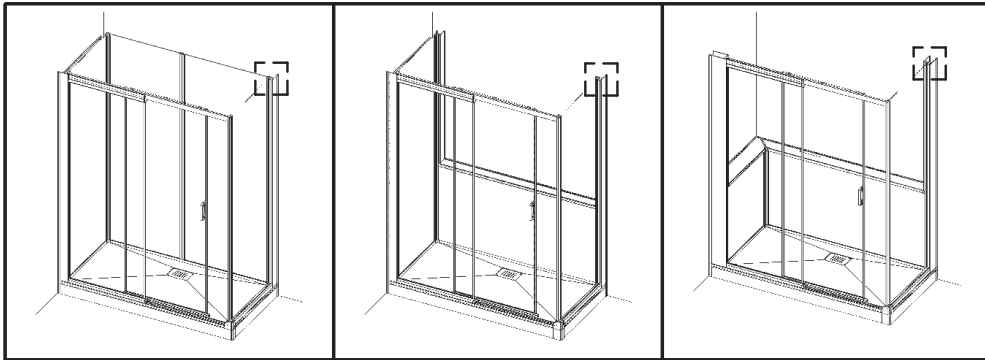

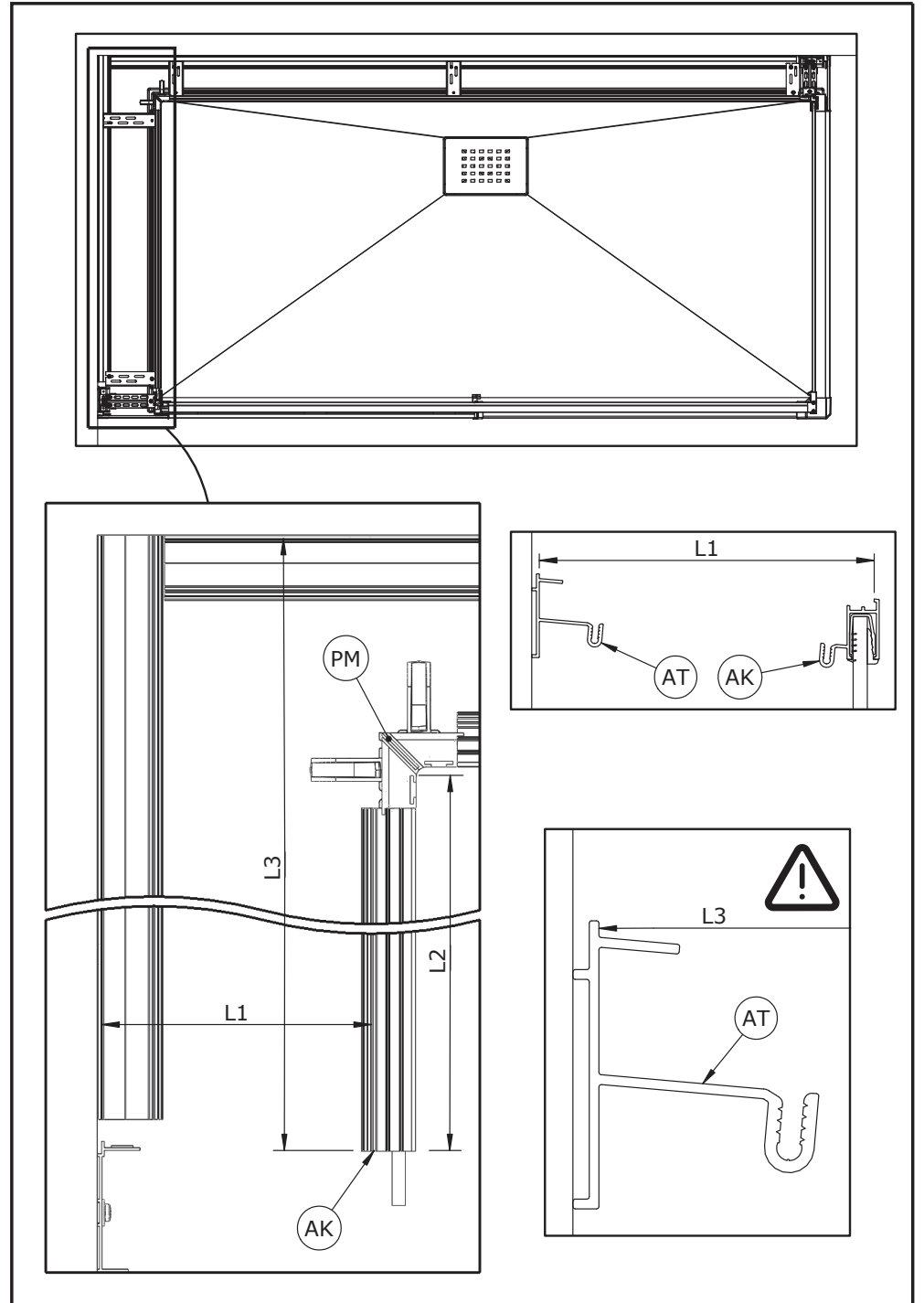
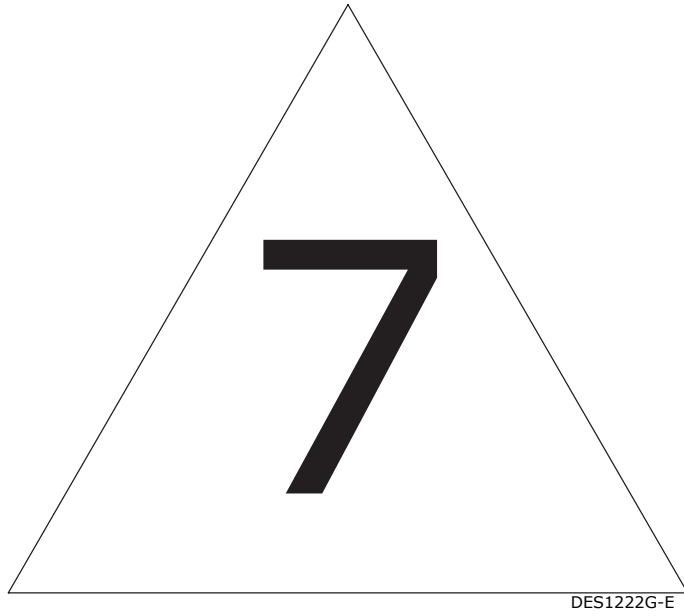

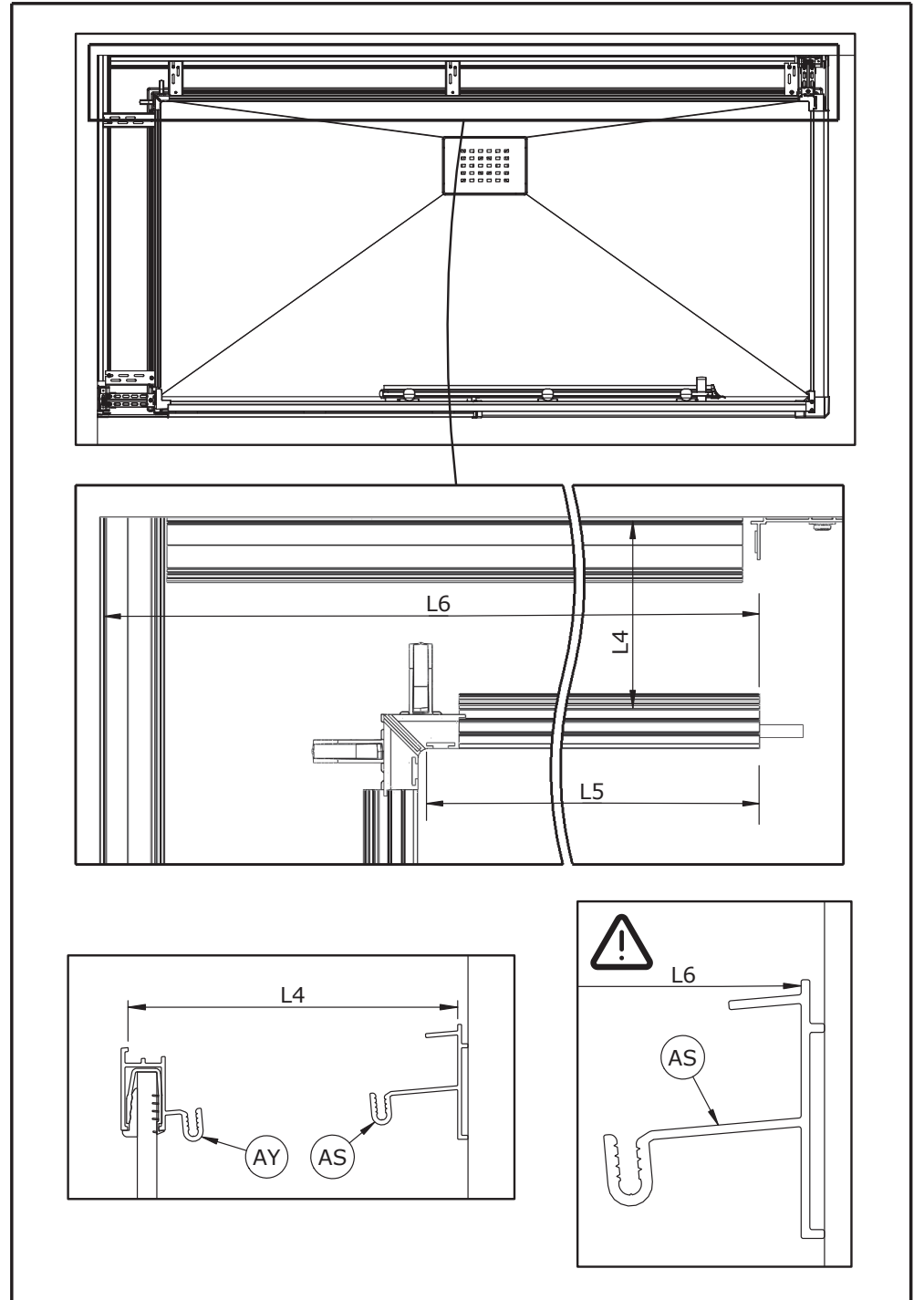
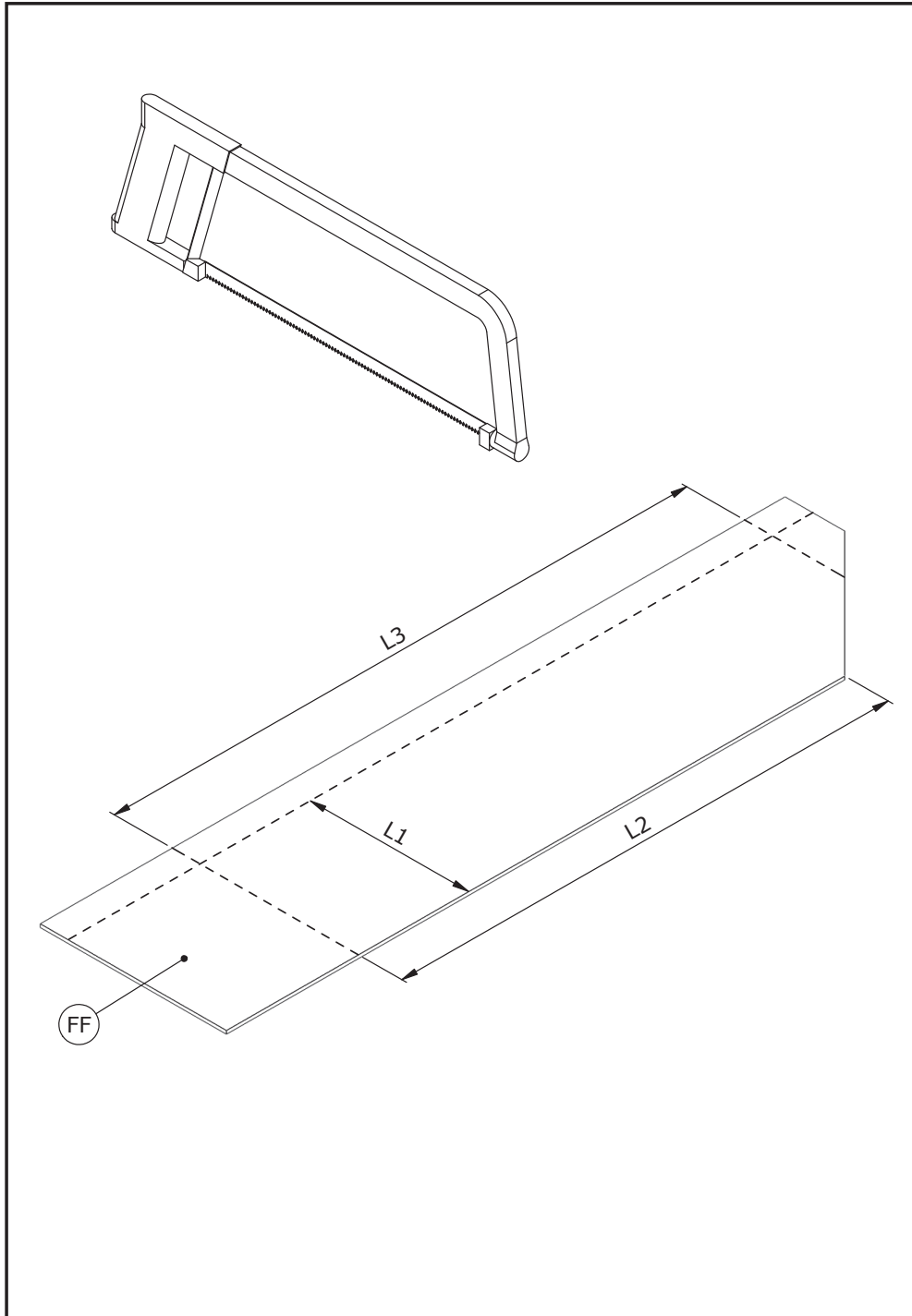

DES1295AG-A

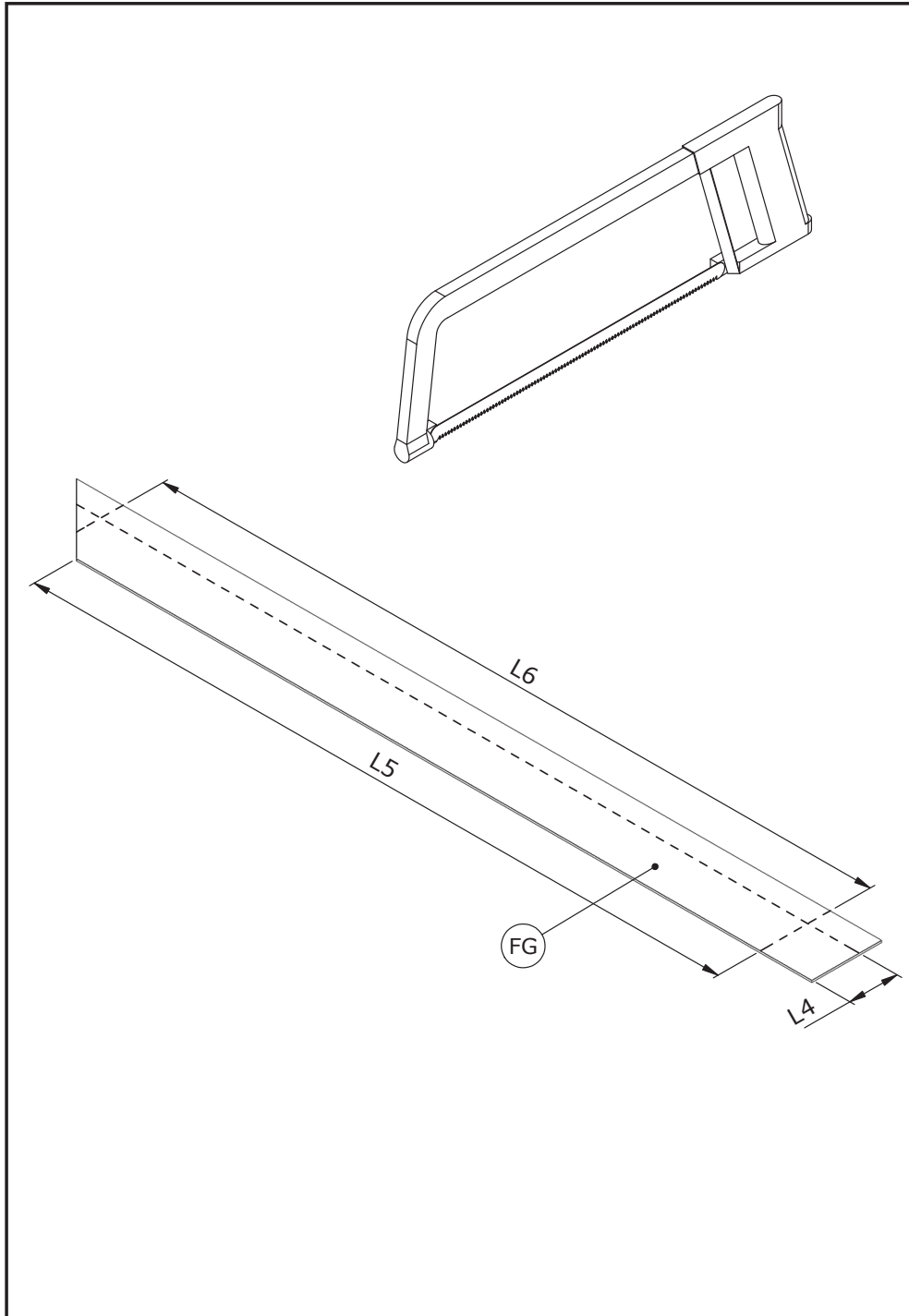

- Pensez à l'emplacement de votre mitigeur. Découpez pour le passage de vos flexibles d'alimentation
- Think the location of your faucet. Cut for passage of your flexible
- No se olvide de las perforaciones para la grifería. Cortar para la ubicación de su grifo
- Fori di passaggio della rubinetteria. Tagliare la struttura per il tubo di scarico
- Vergeet niet de mengkraan aan te brengen. Zorg voor een opening voor de waterslangen
- Denken sie an die position ihrer armatur. Für den Durchgang der Zulaufschläuche zuschneiden

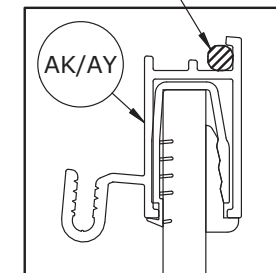
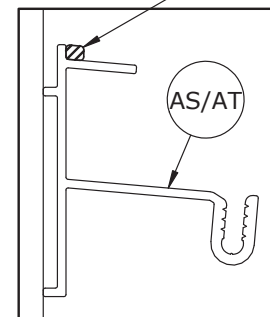
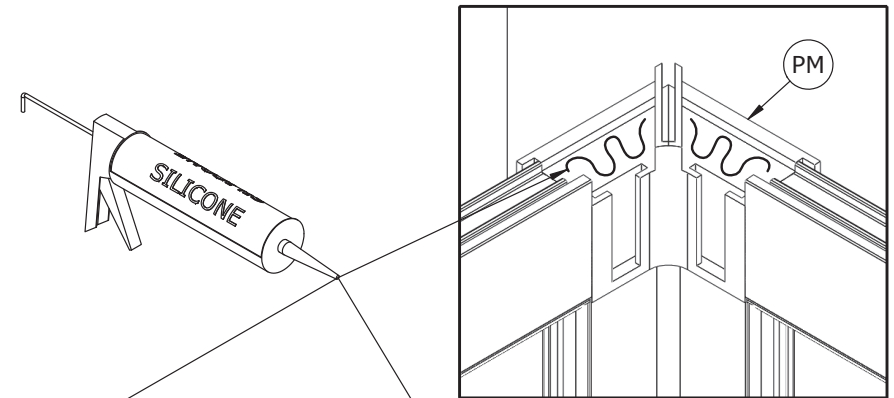
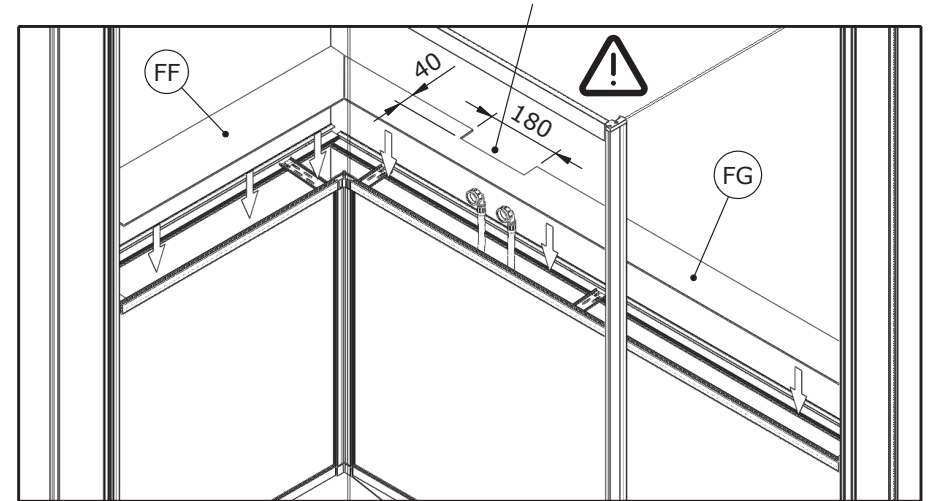

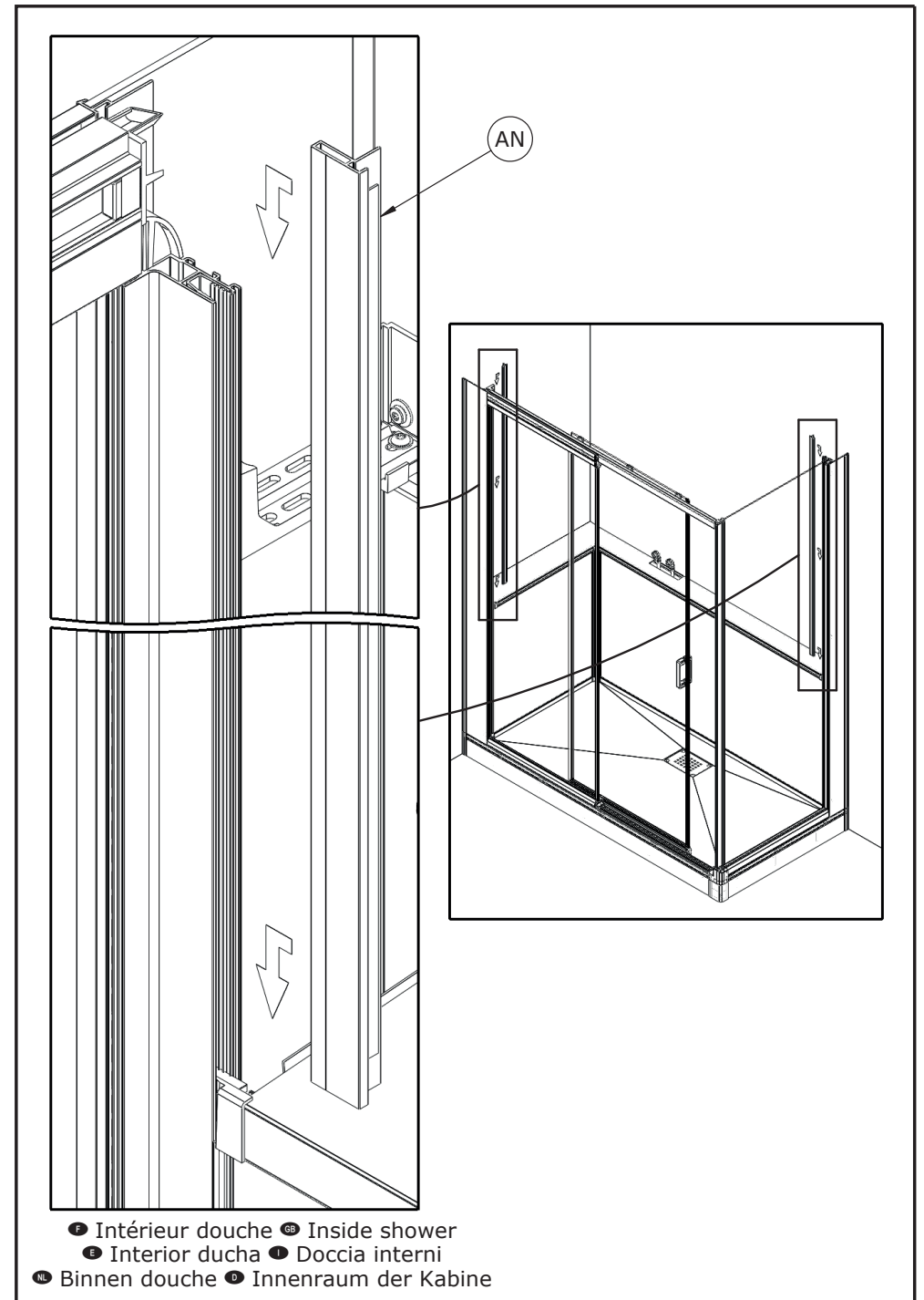
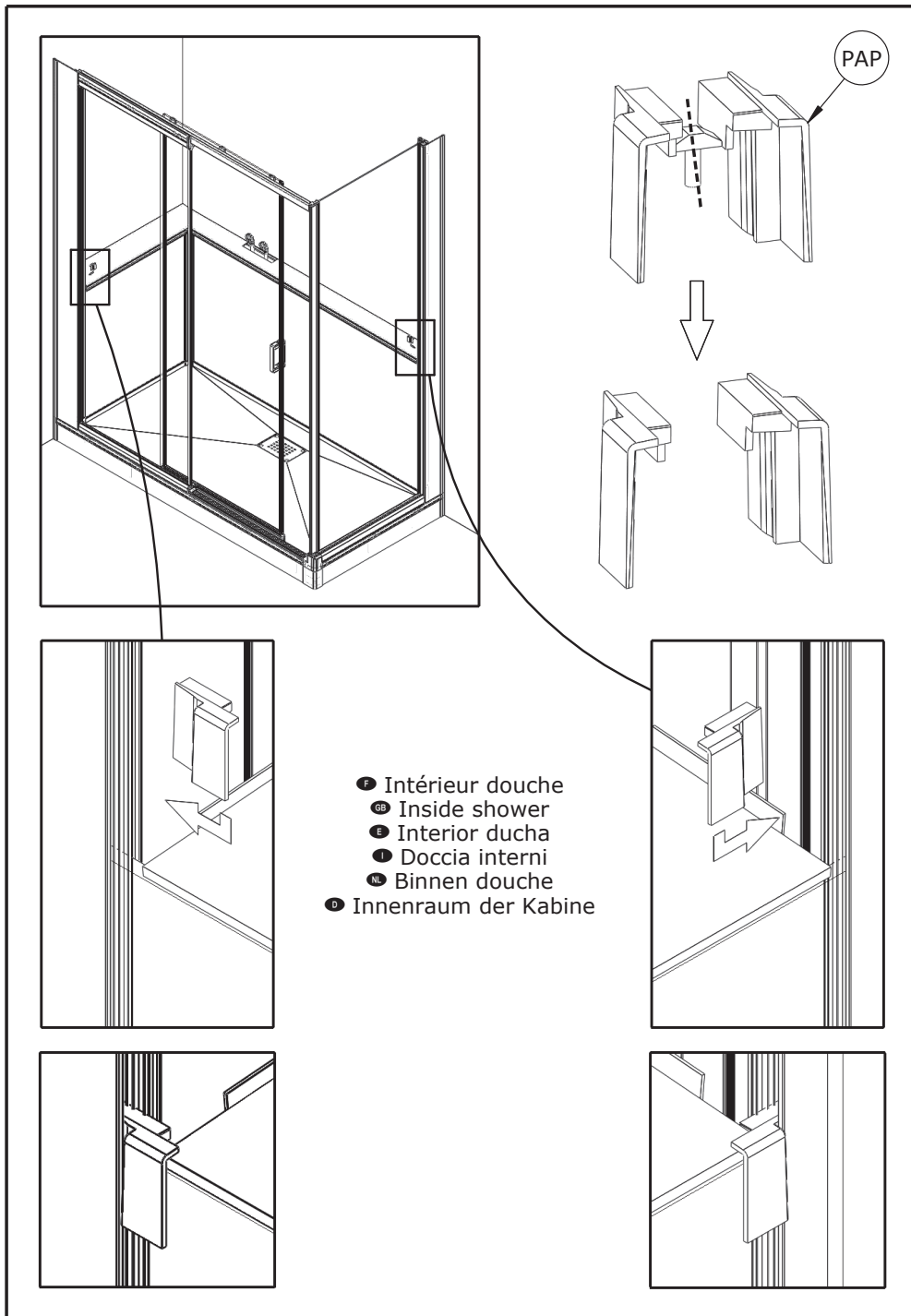

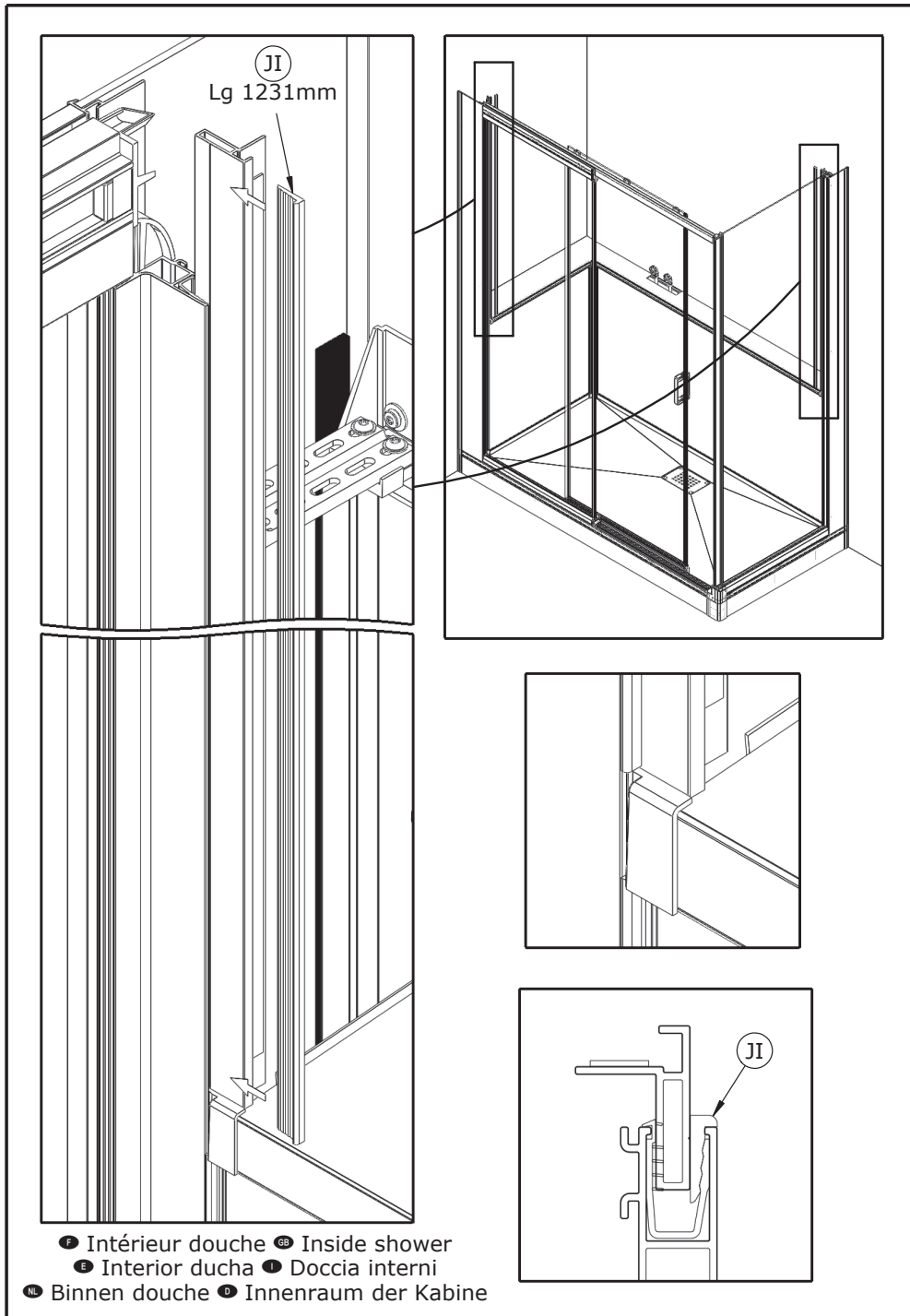

- Intérieur douche ● Inside shower
- Interior ducha ● Doccia interni
- Binnen douche ● Innenraum der Kabine

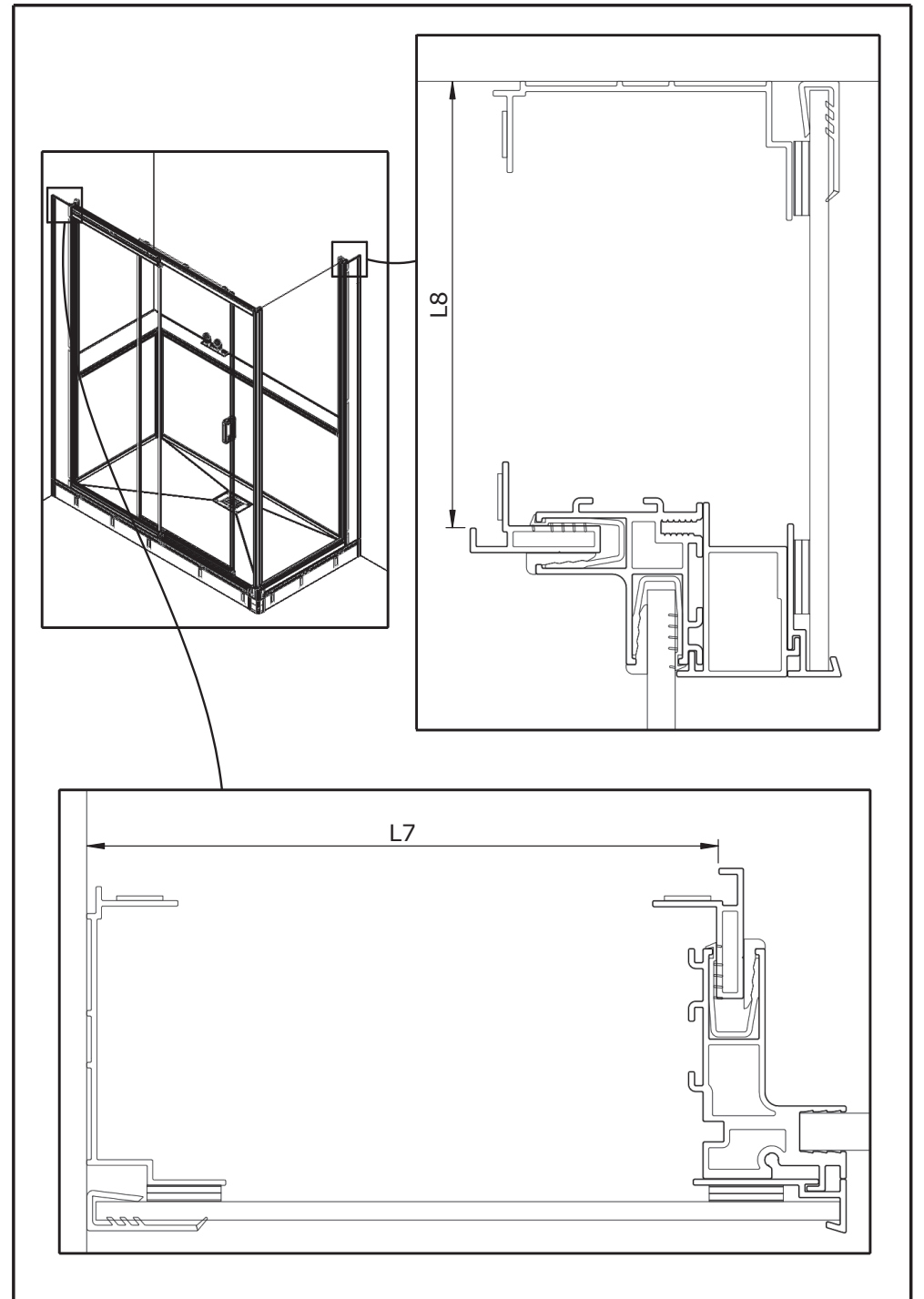

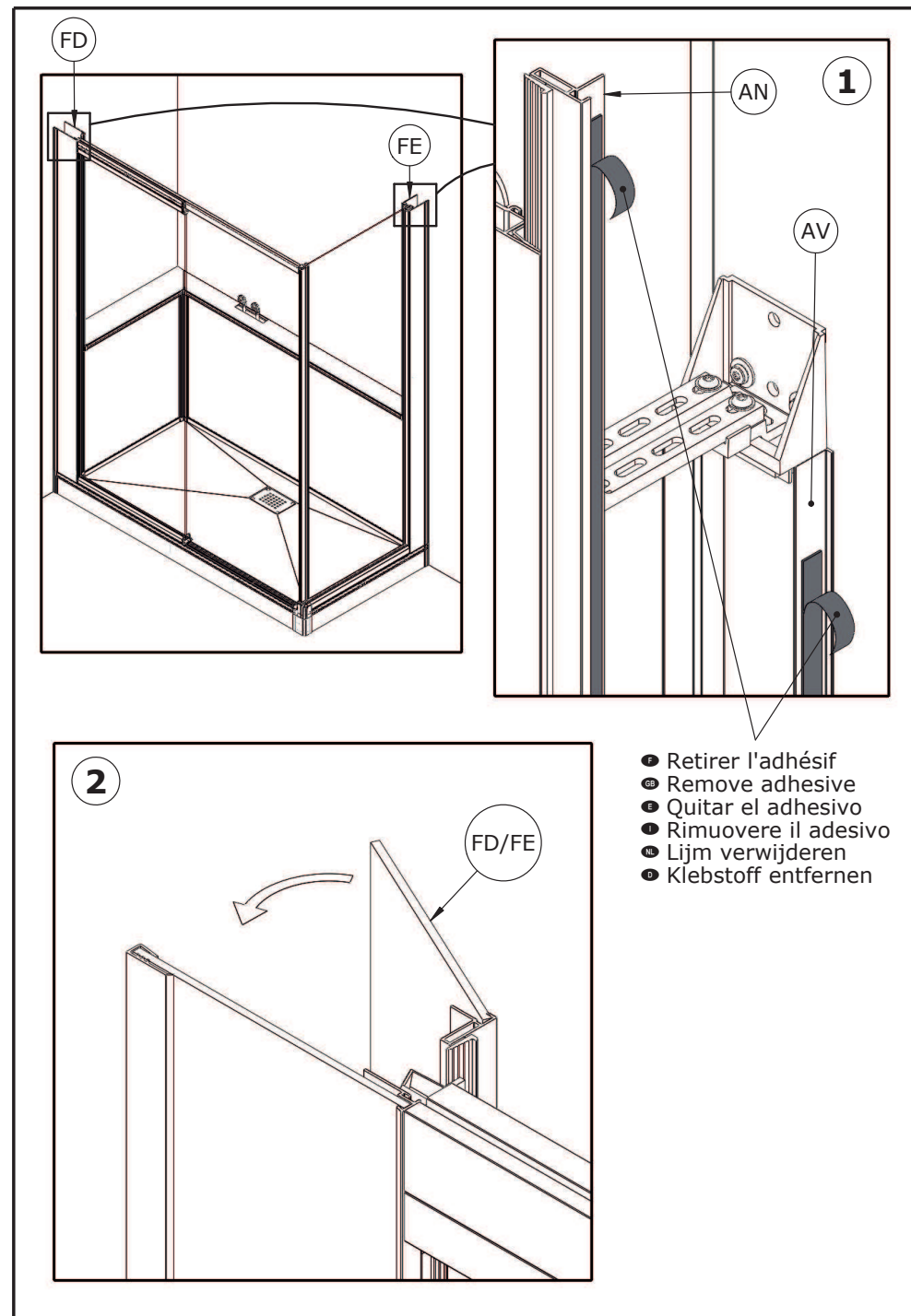
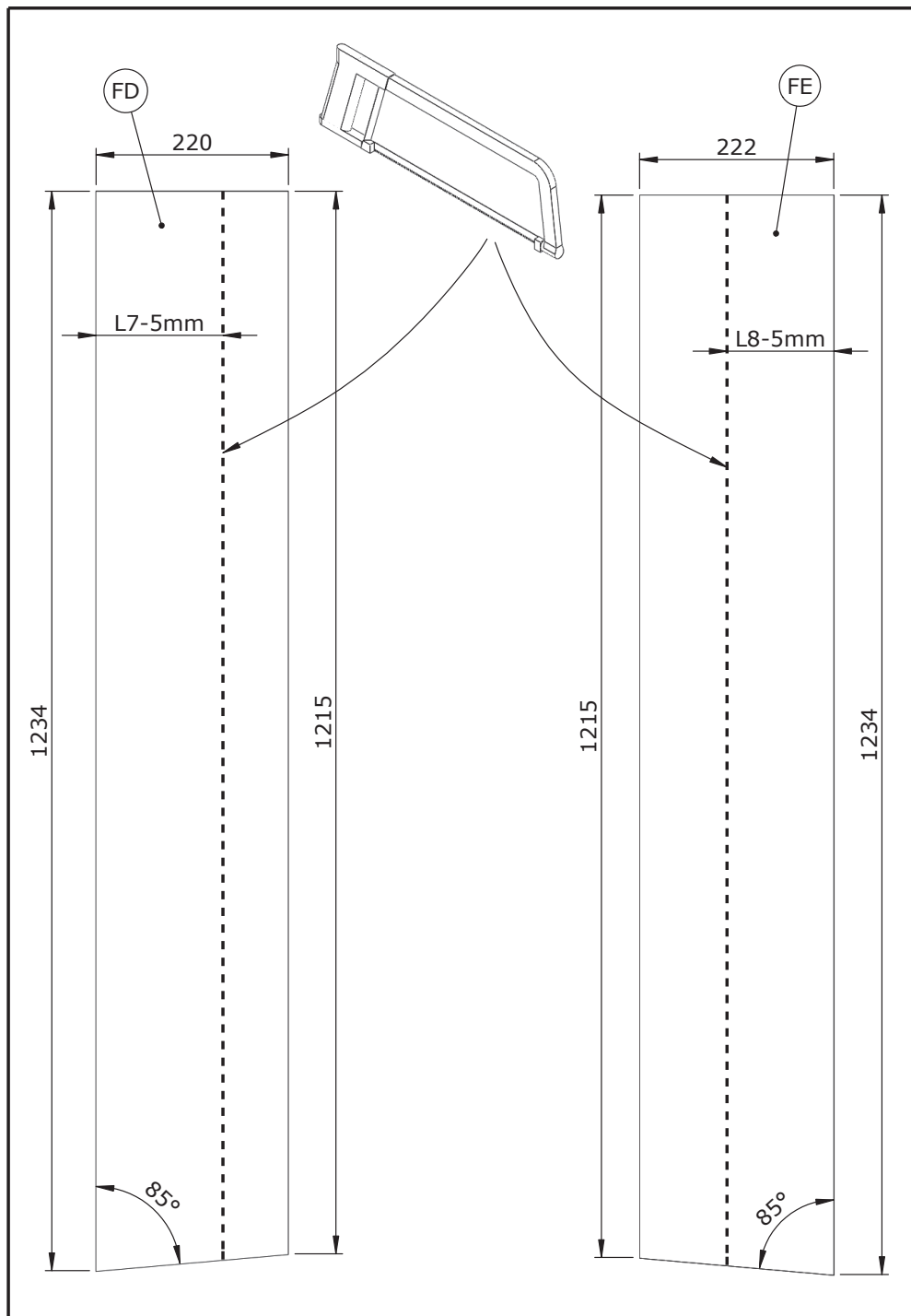

- Ⓕ Retirer l'adhésif
- Ⓖ Remove adhesive
- Ⓗ Quitar el adhesivo
- Ⓜ Rimuovere il adesivo
- Ⓝ Lijm verwijderen
- Ⓟ Klebstoff entfernen

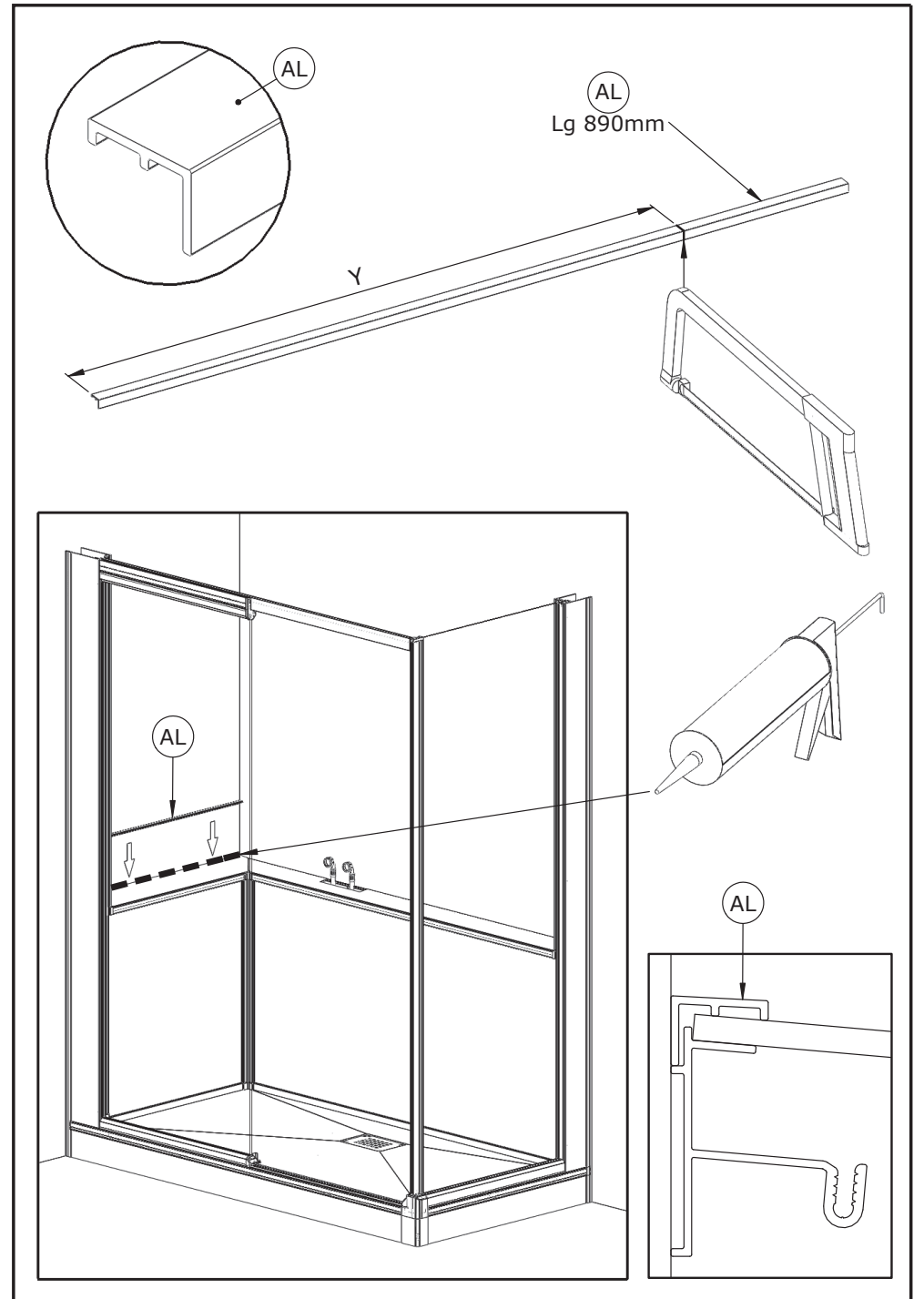
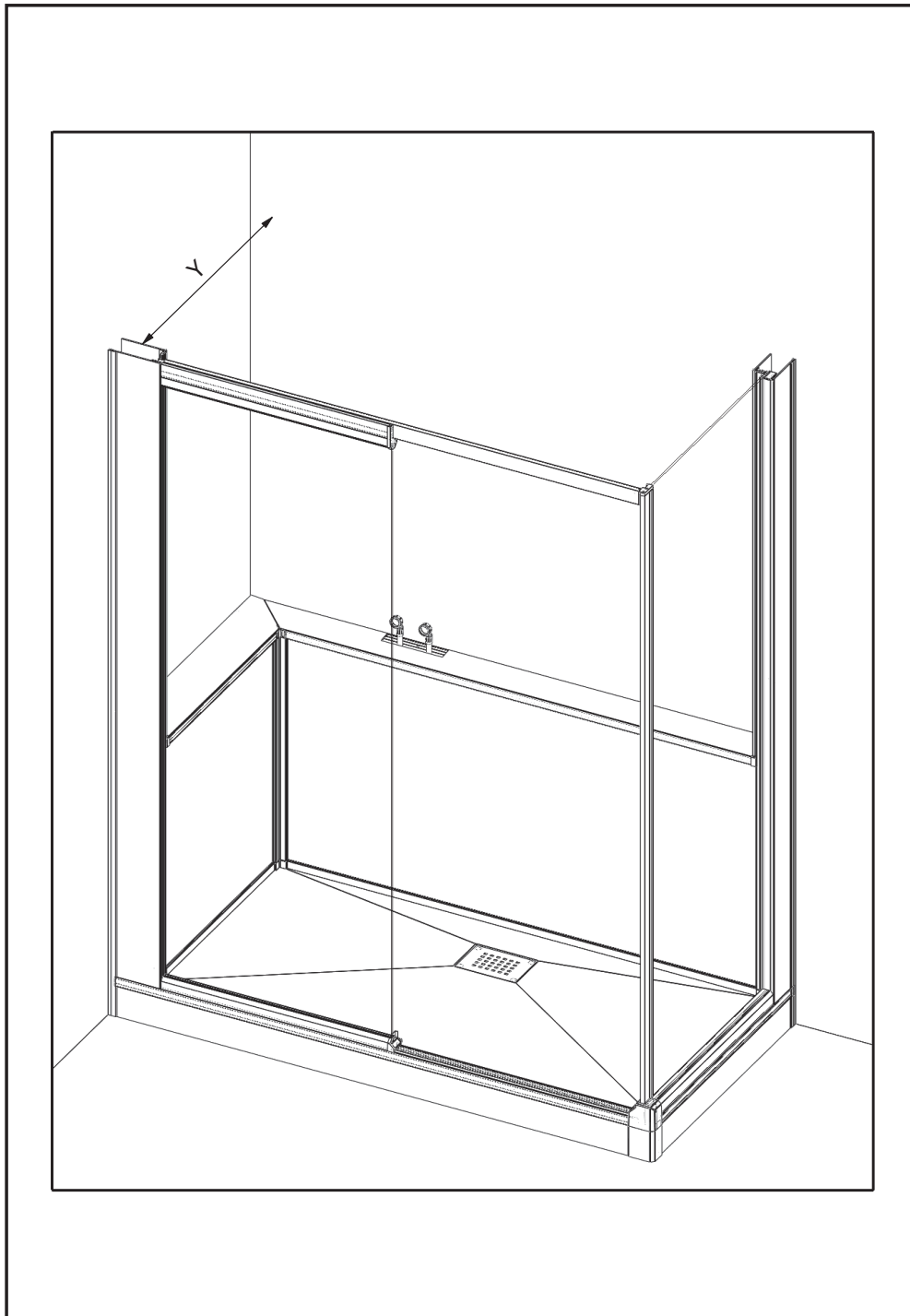

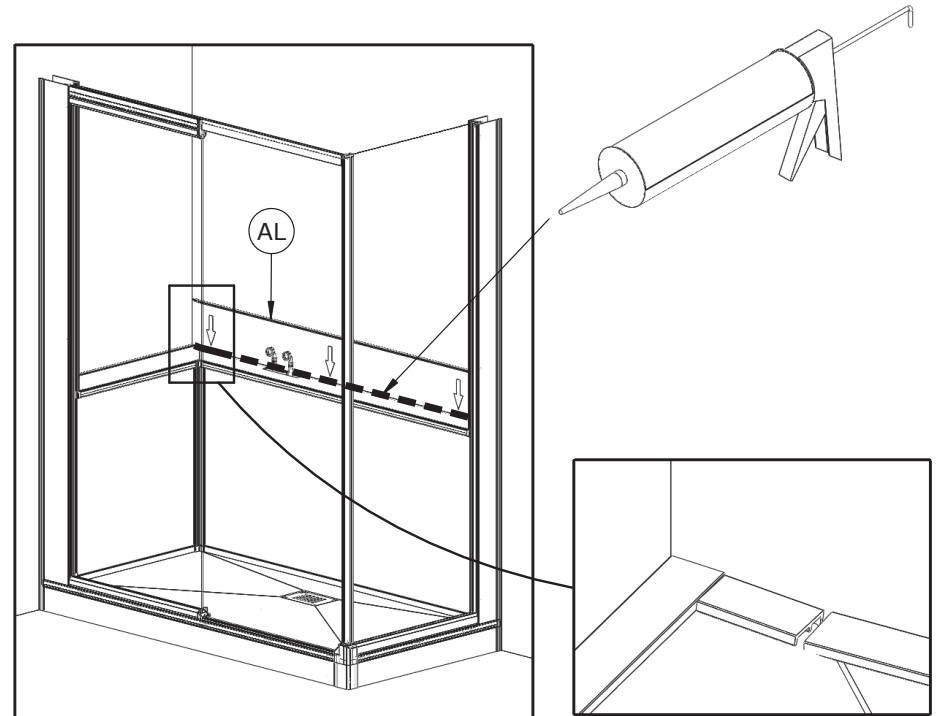
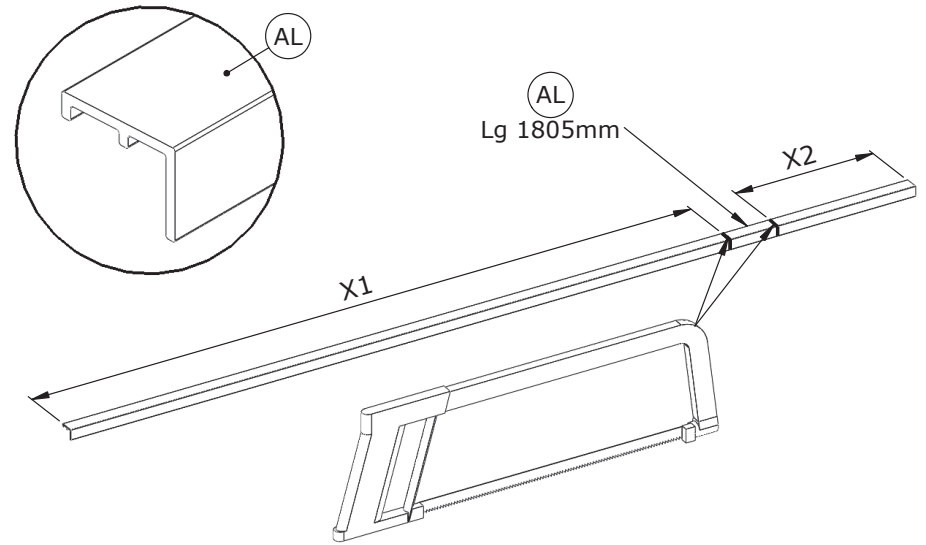
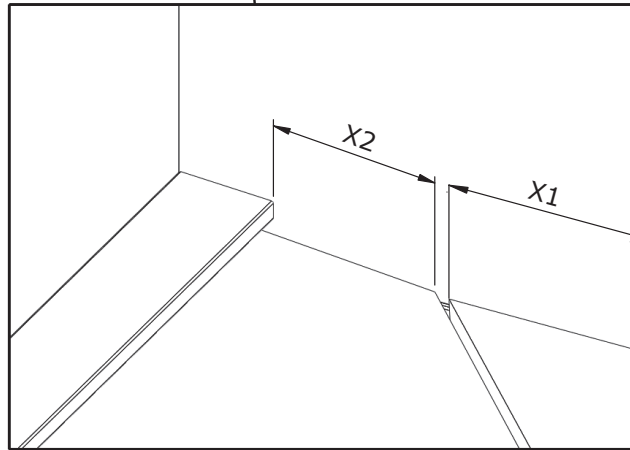
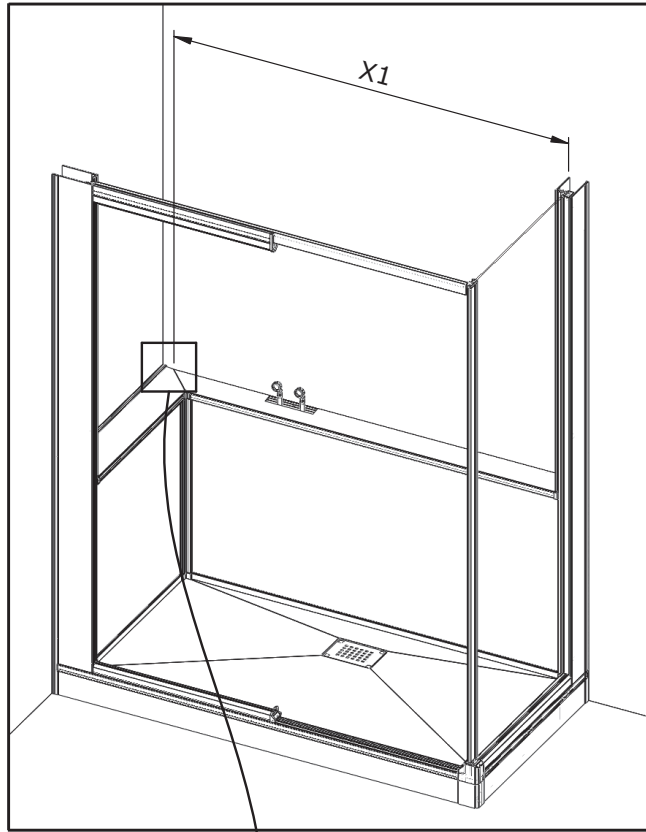

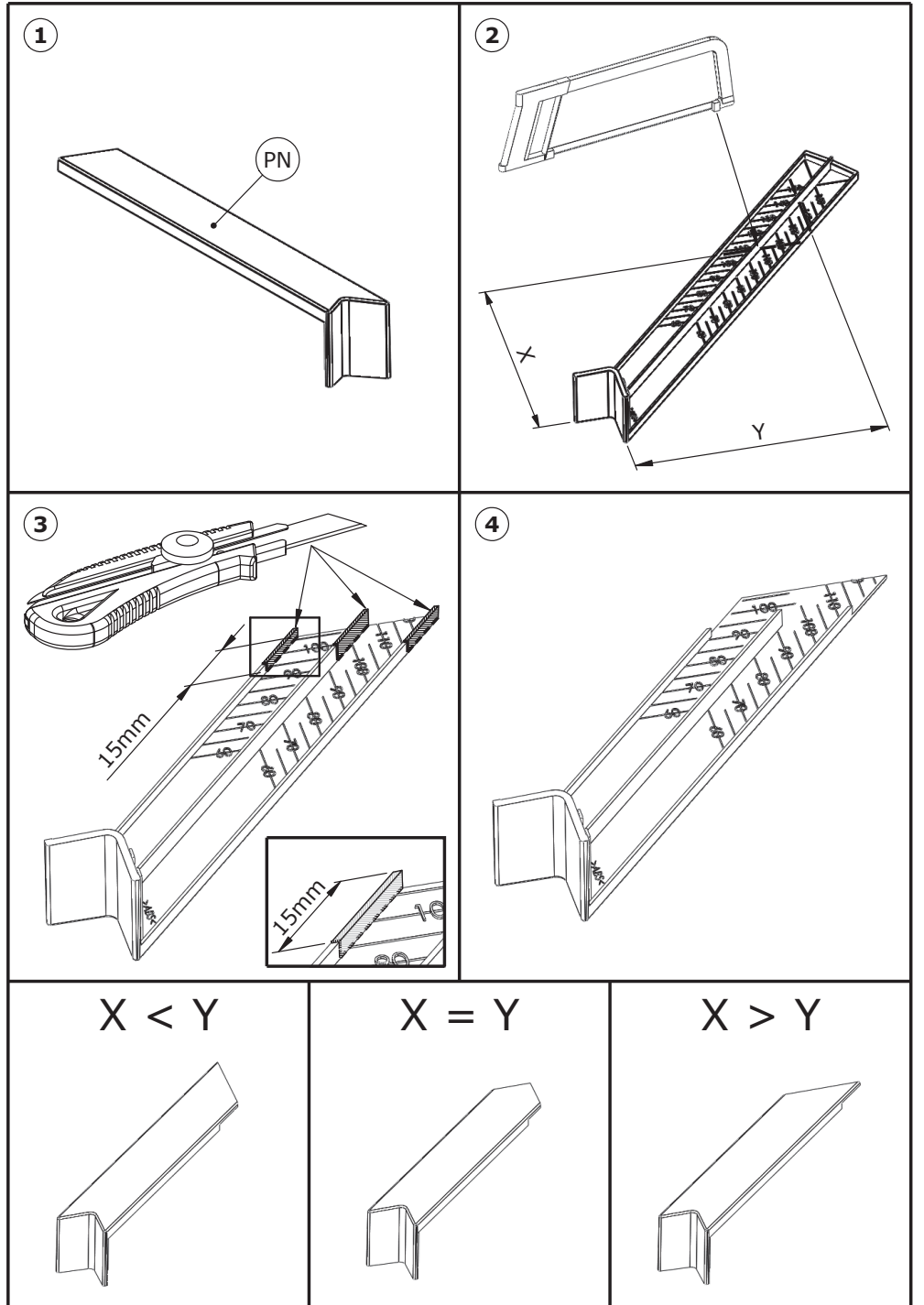
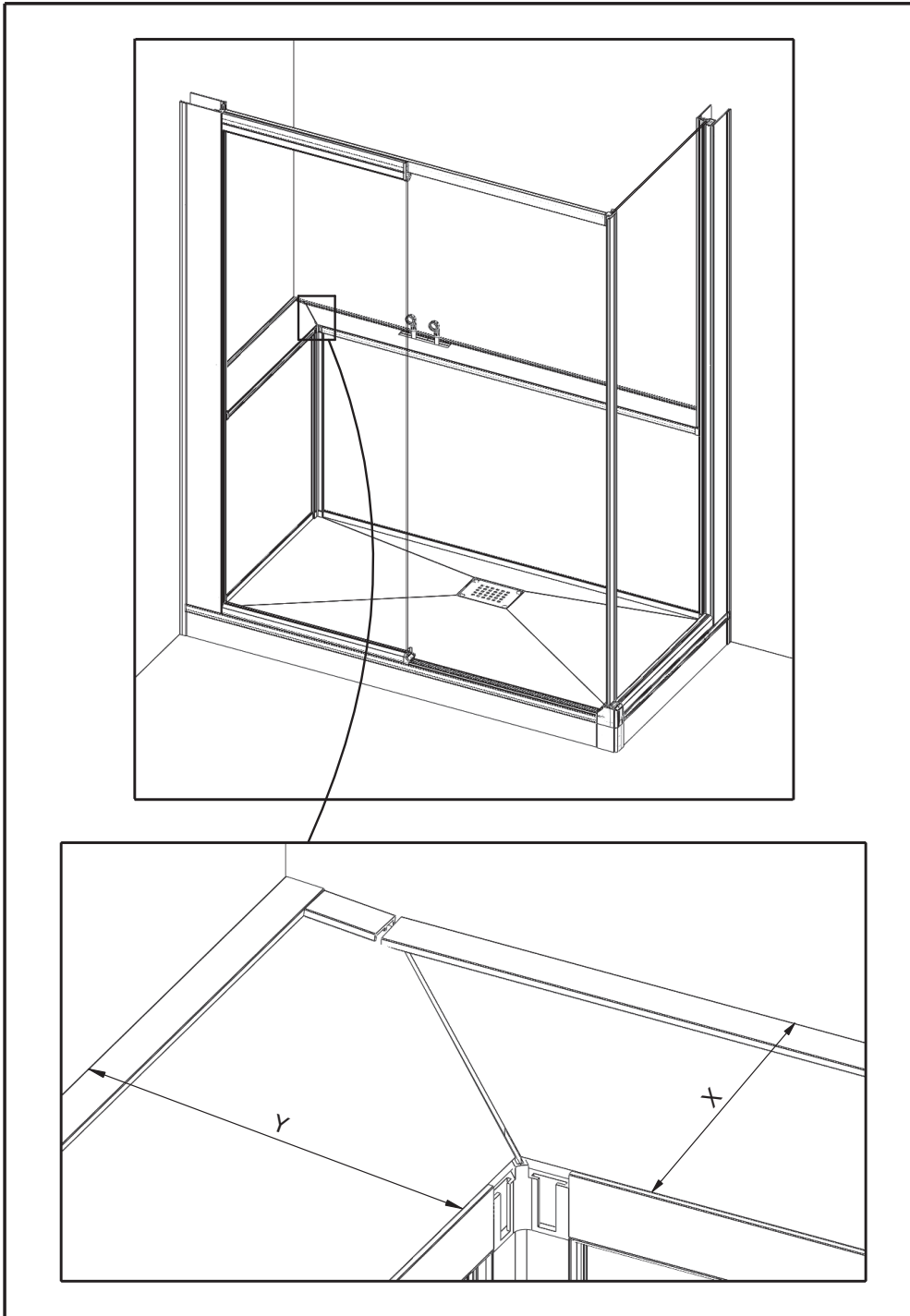

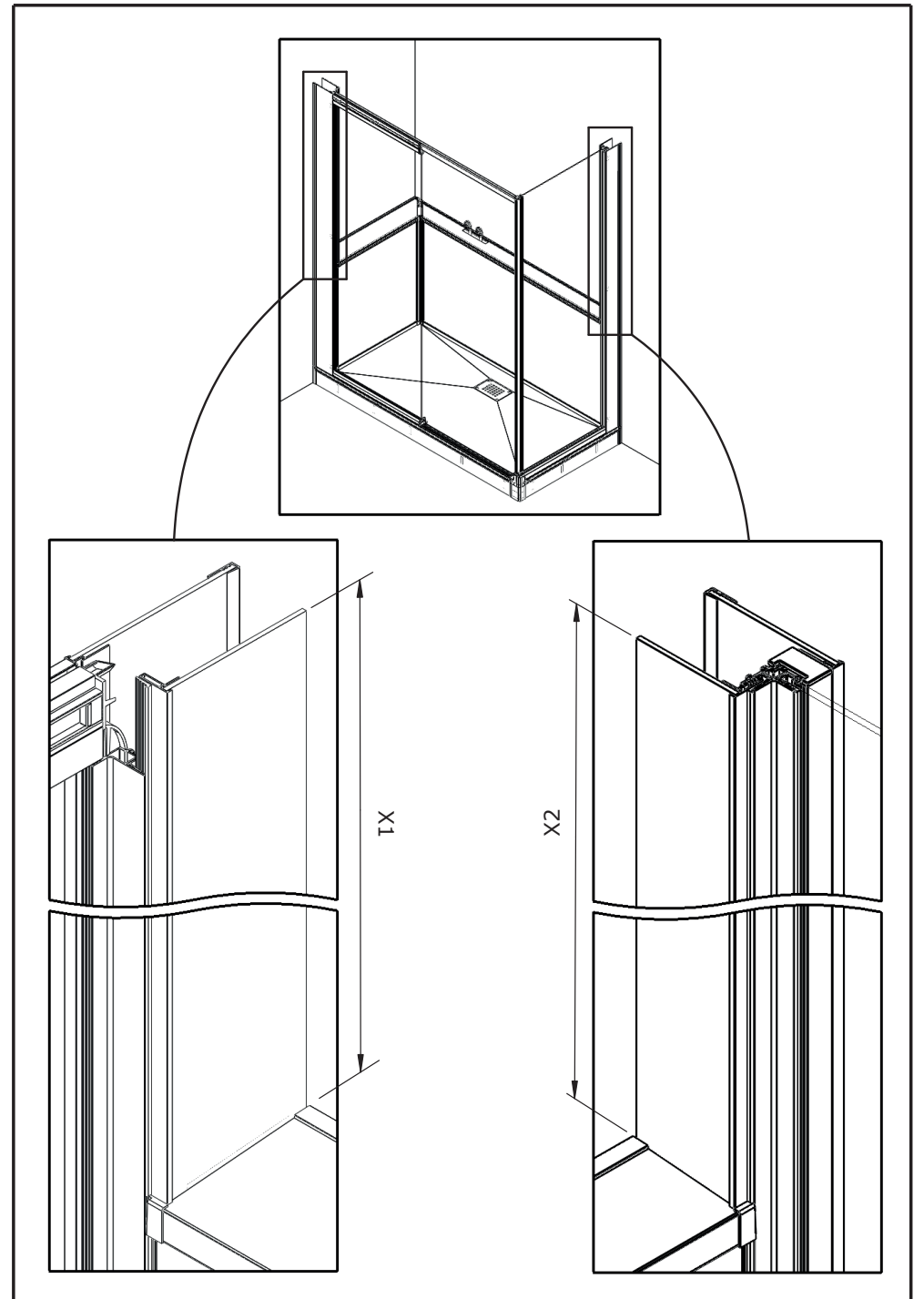
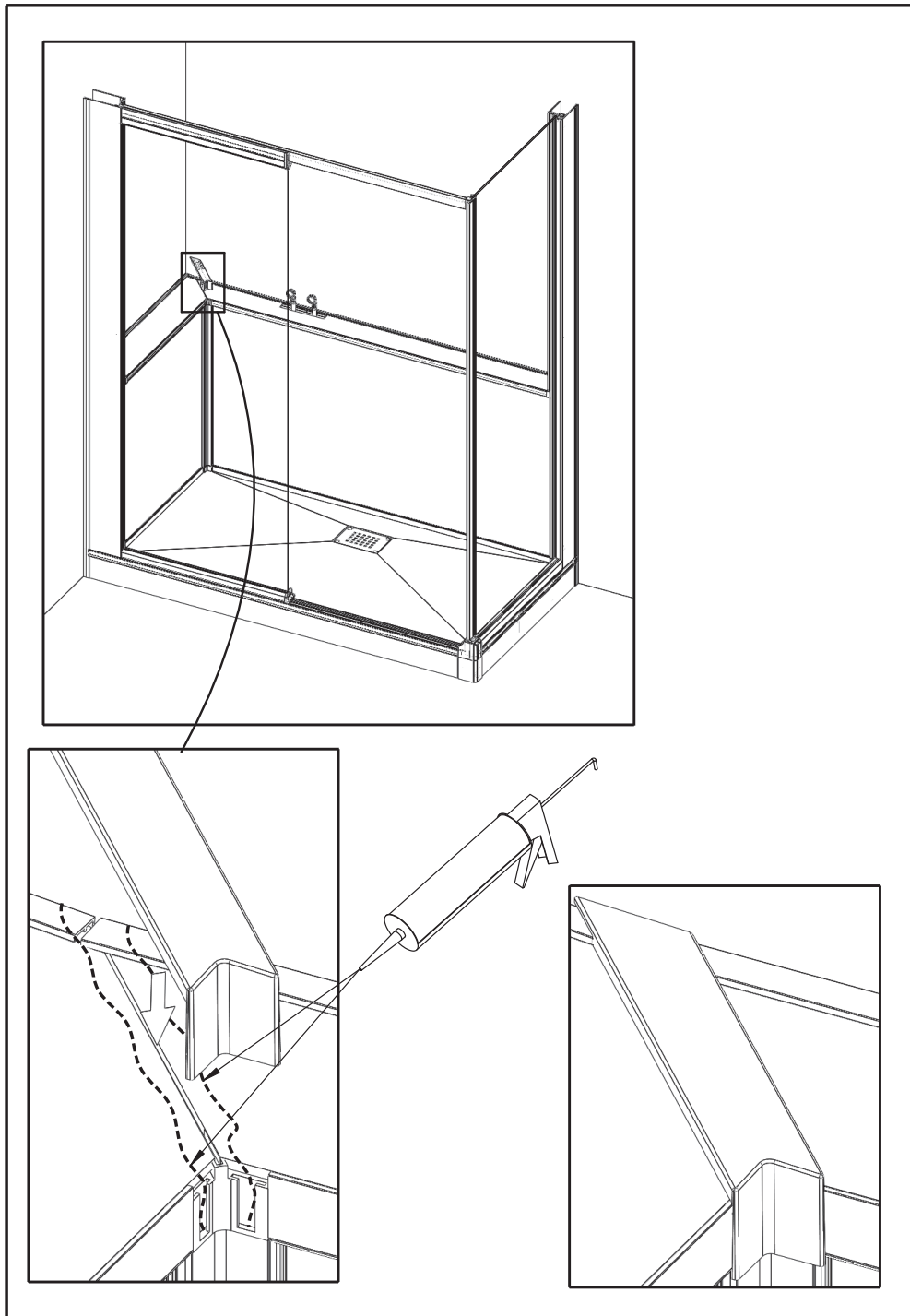

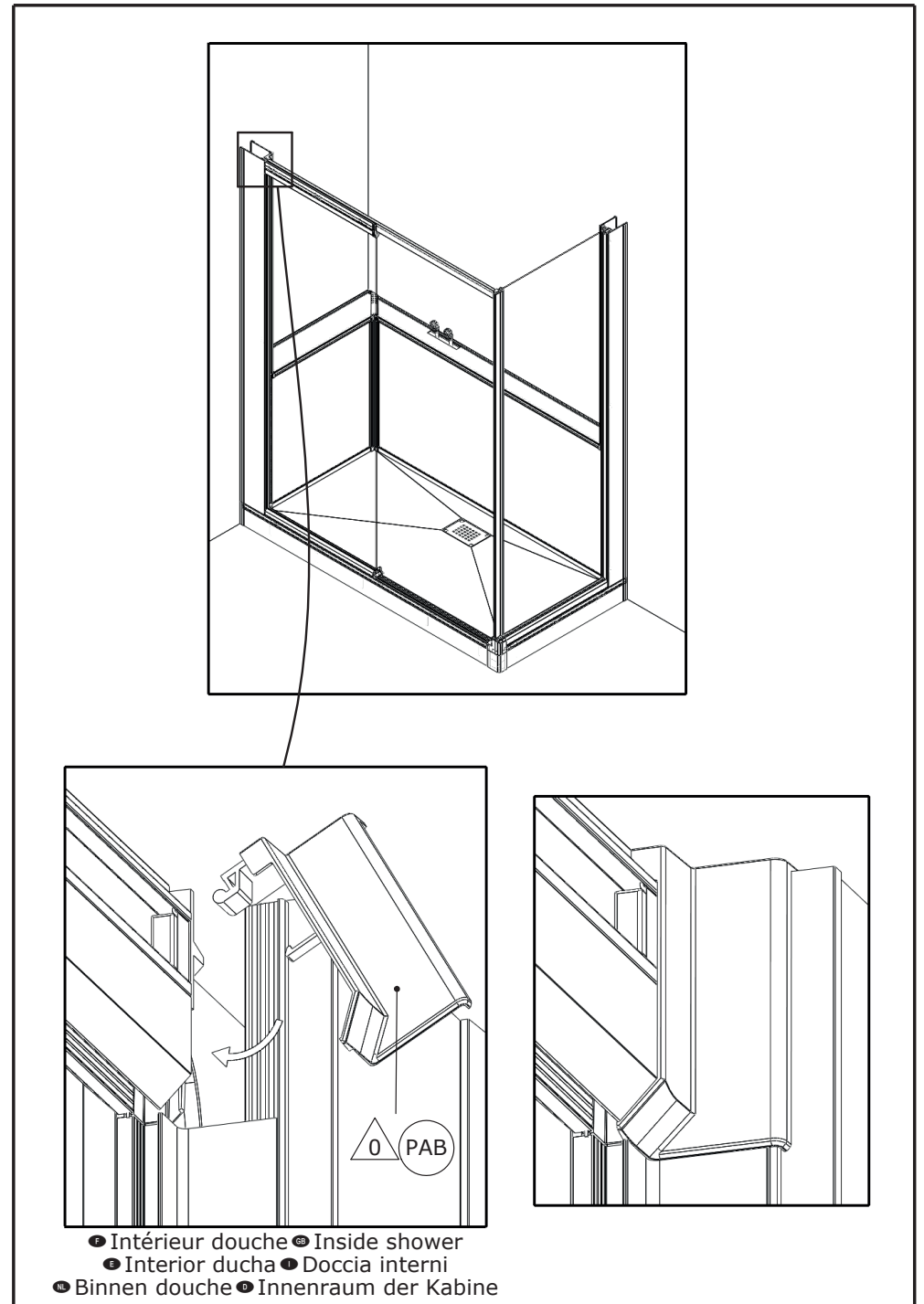
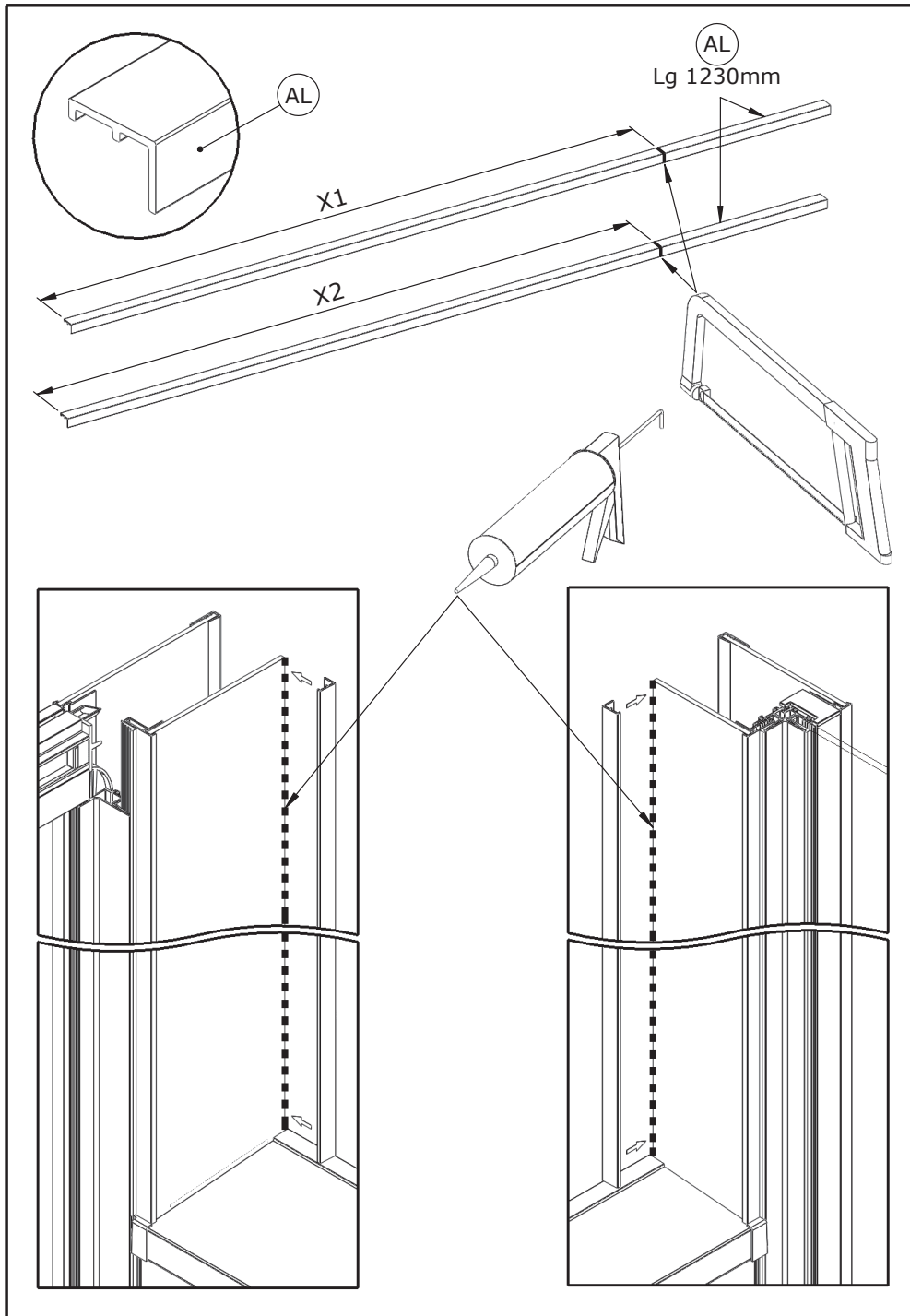

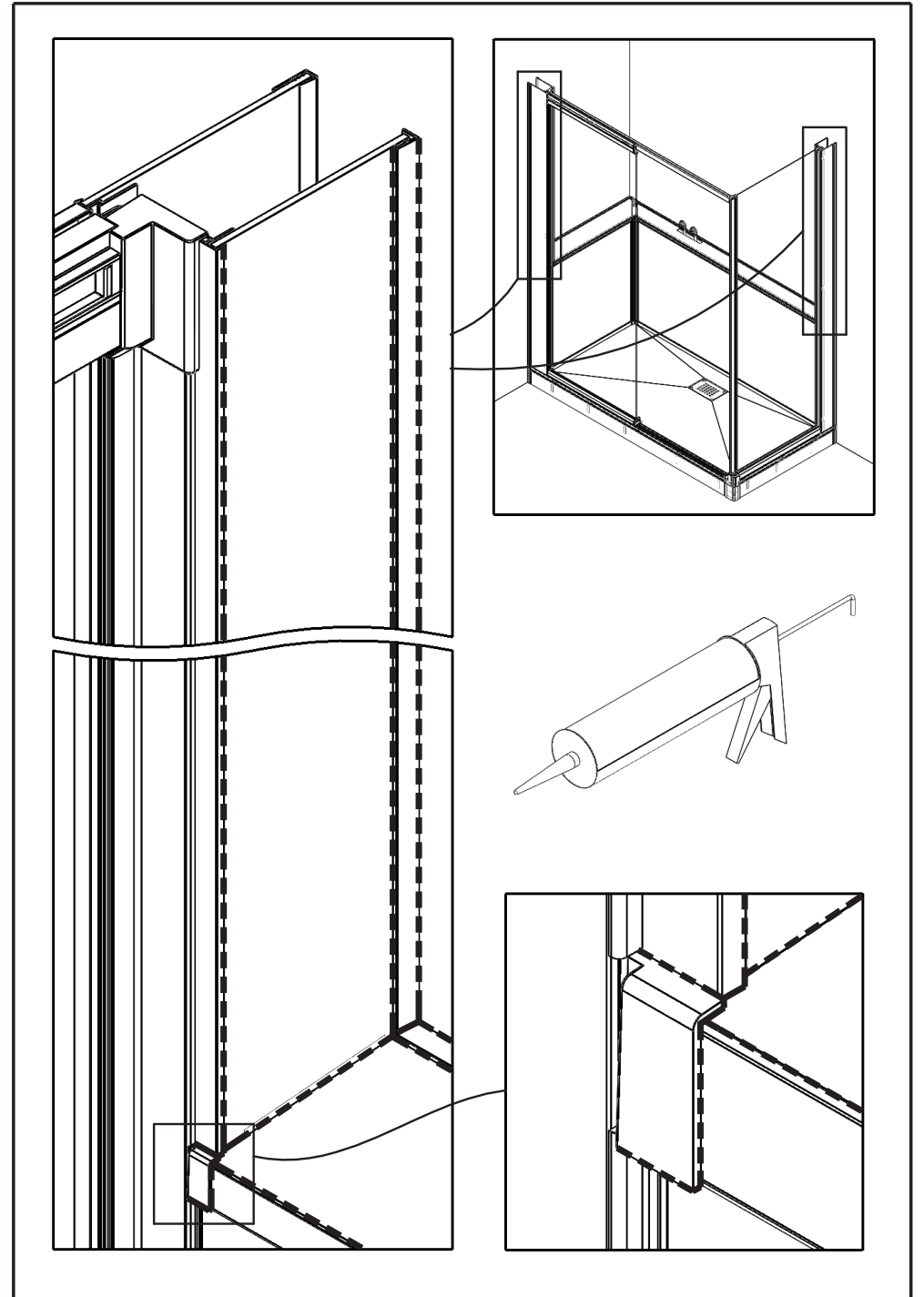
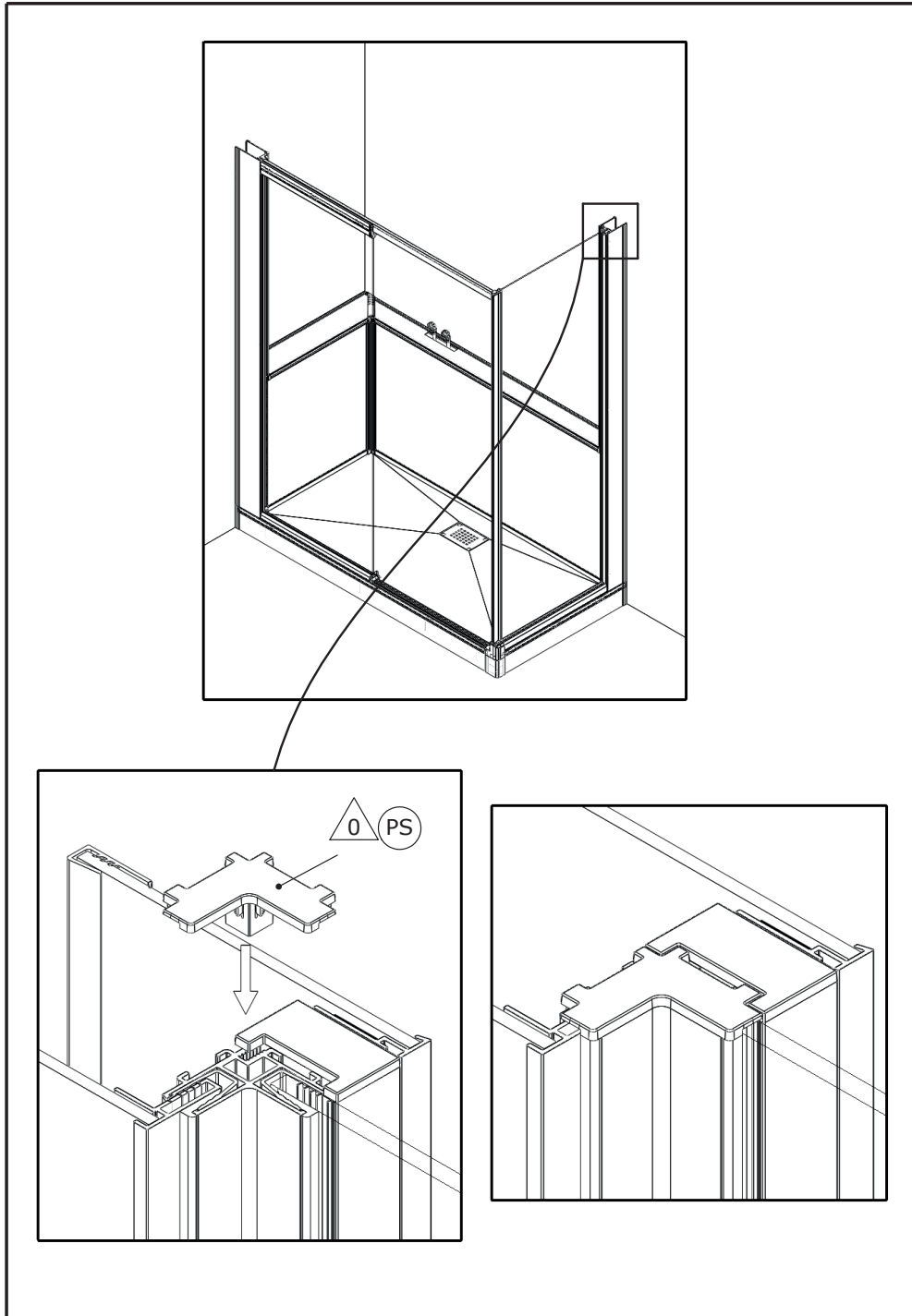

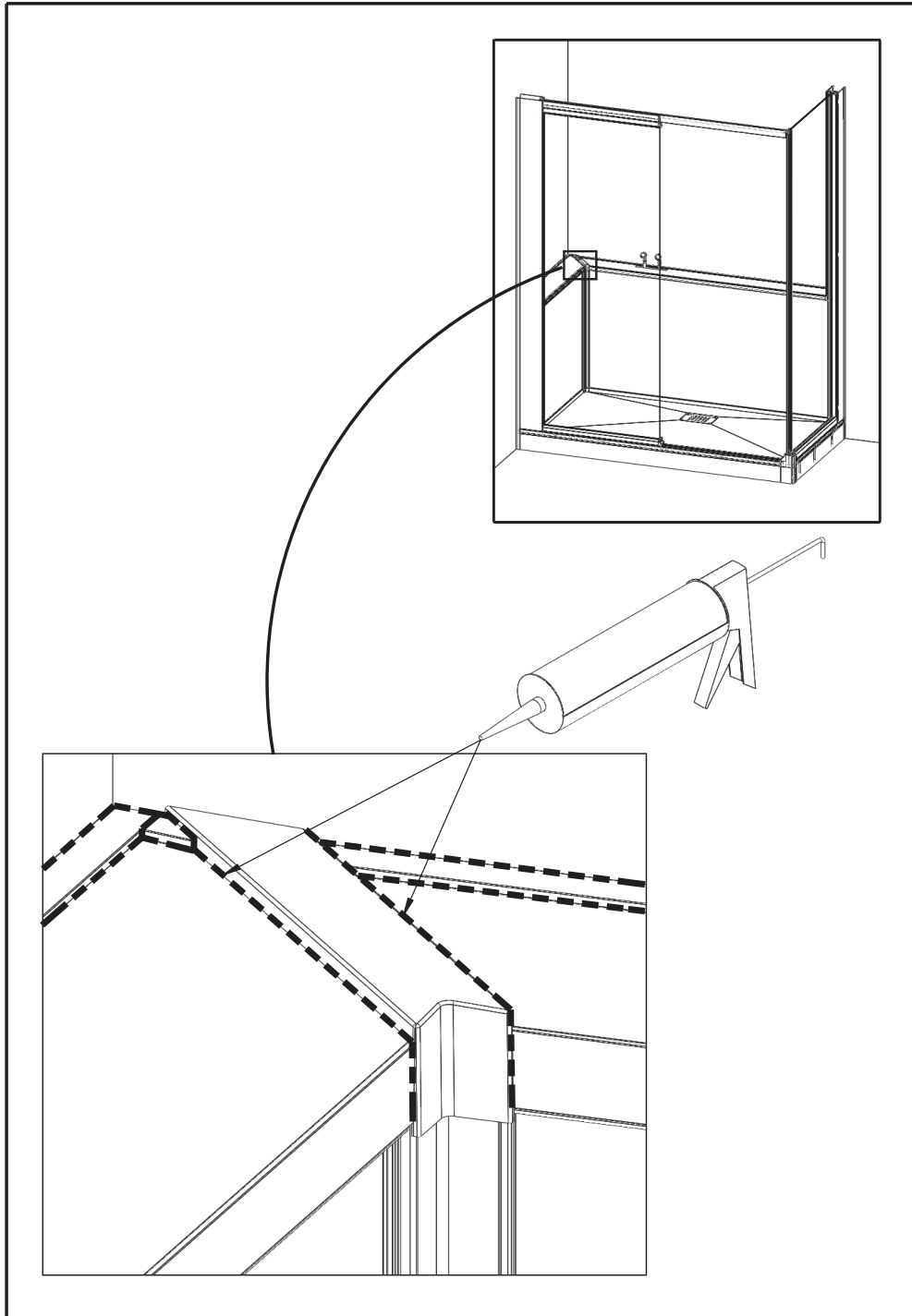

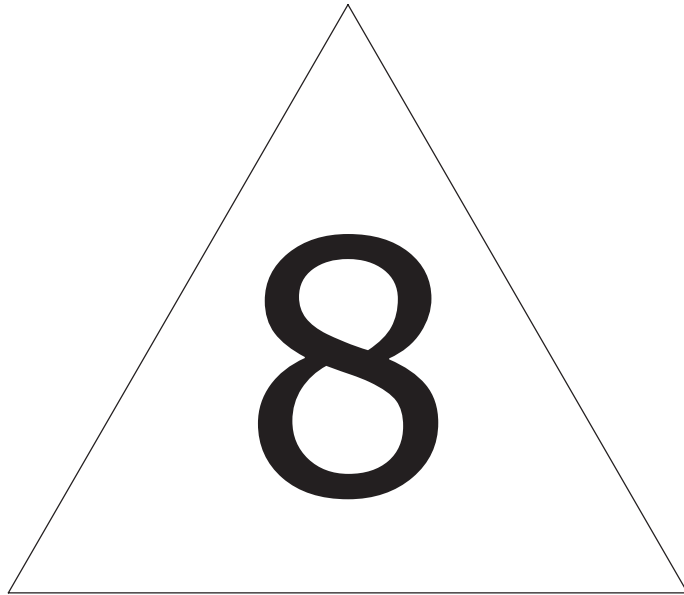

DES1223A

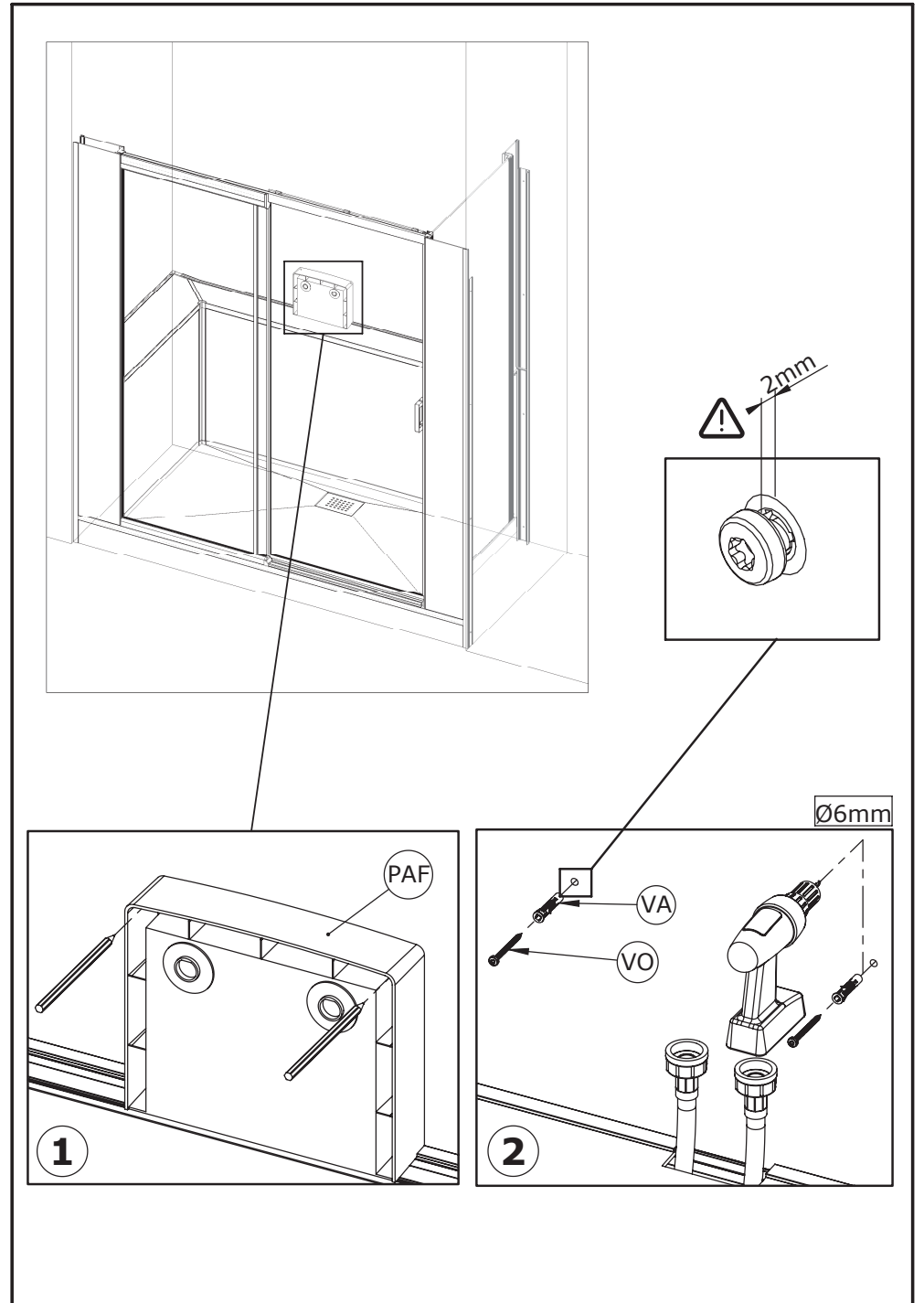

VERSION SANS MITIGEUR

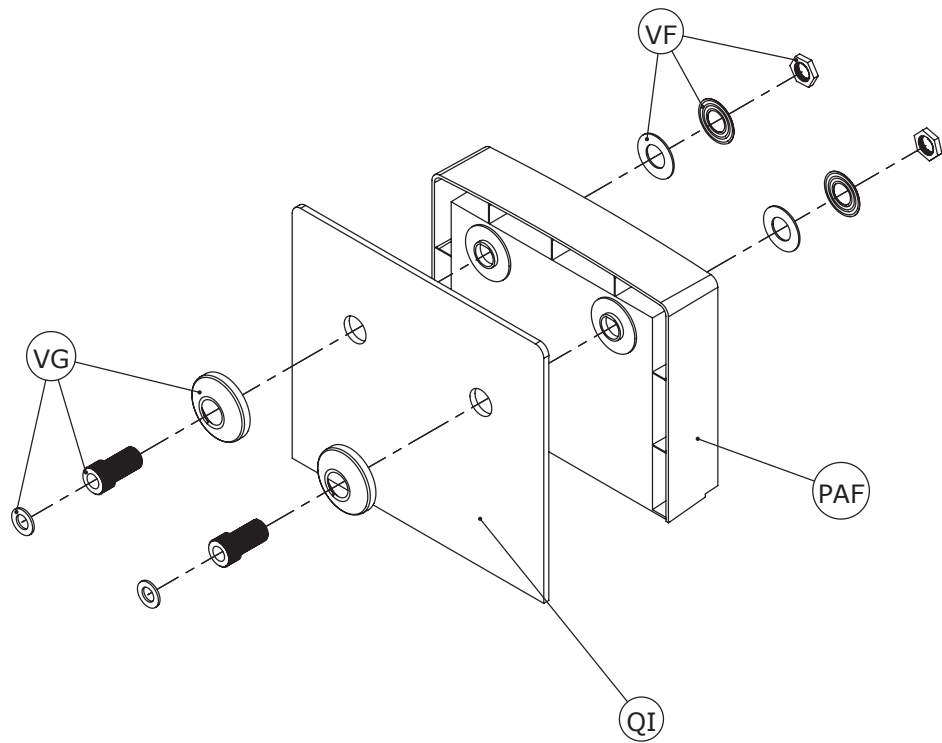

MECA

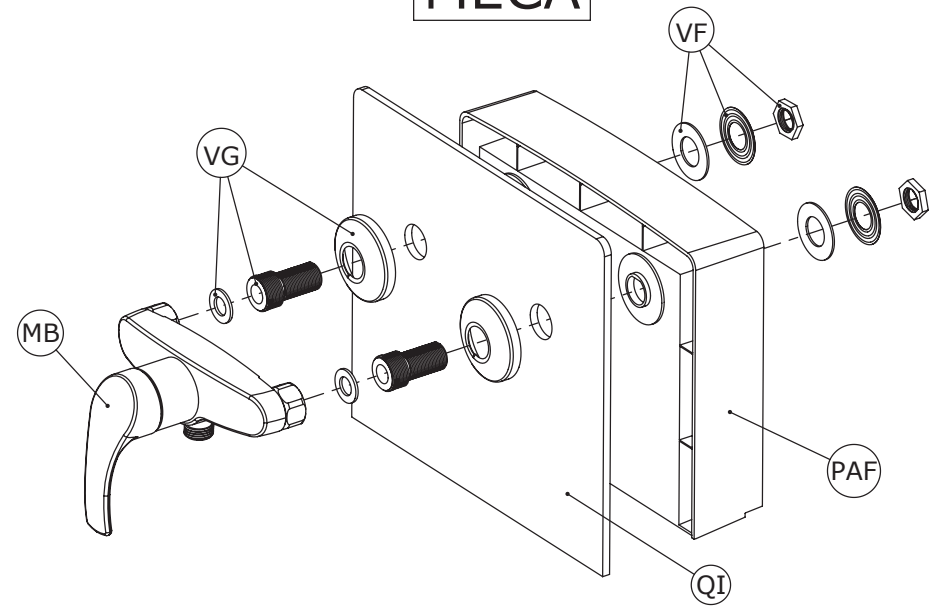

THERMO

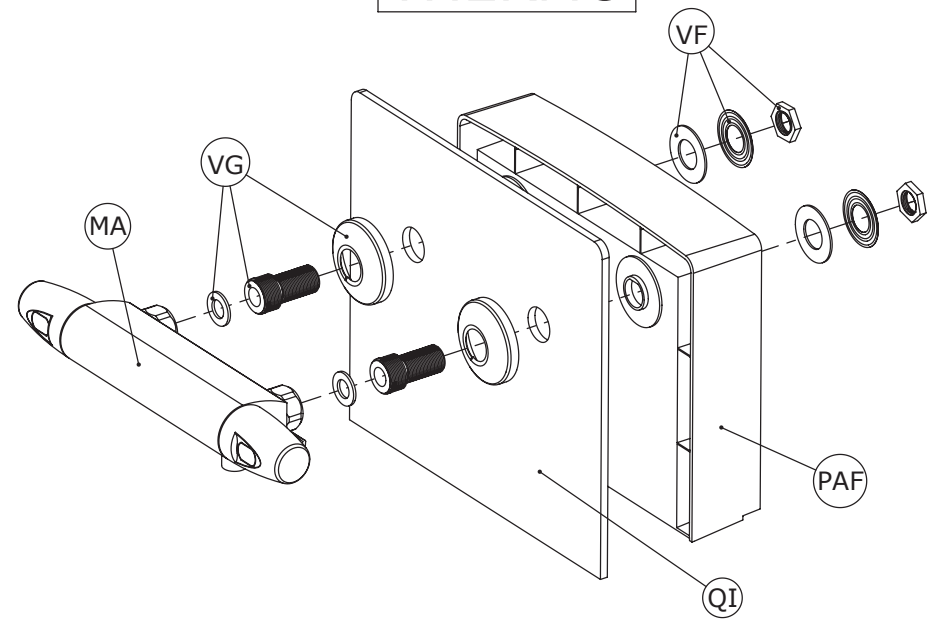

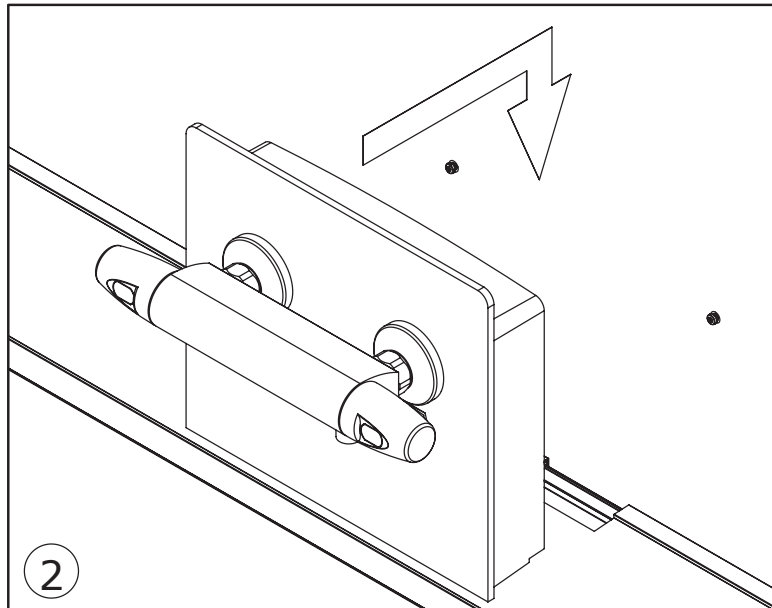
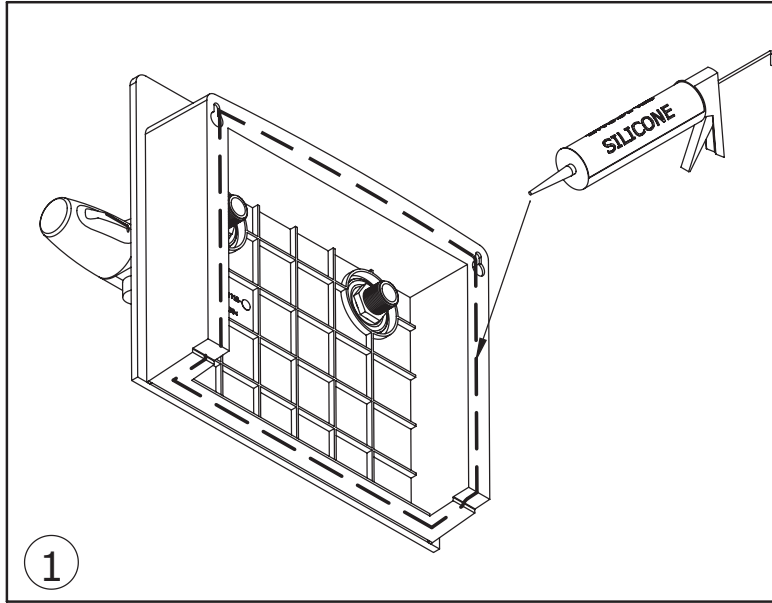



SAV
SERVICE HELPLINES
ASSISTENZA POST-VENDITA
SERVICIO POSTVENTA

FRANCE

02 40 21 29 45

SCHWEIZ

(01) 748 17 44

UK

020 8842 0033

ESPANA

93 544 60 76

IRELAND

04697 33102

NEDERLAND

+31 475 487 100

DEUTSCHLAND

+49 (0) 6074 / 30928 0

BELGIË

+31 475 487 100

ITALIA

(0382) 6181

BELGIQUE

+31 475 487 100

ÖSTEREICH

+43 1 710 60 70

РОССИЯ

963 19 40, 773 67 22